

EB Series Electro Brake

Shaft Mounted Brakes for Power-On Applications

Pre-engineered, pre-packaged brakes mount on motor or thru shafts. They have been designed to mate easily with industry standard motors, reducers and other power transmission components. Bolt-it-down and wire-it-up . . . they're ready to go.

- Wide torque range from 16 to 465 lb. ft.
- Handle 1 to 75 HP at 1800 RPM
- Adjustable torque arm

UL Listed

Conduit box meets industry standards.

Long Life, No Maintenance

Automatically adjusts for wear. Designed for maximum heat dissipation. No lubrication necessary.

Mounting Flexibility

Torque arm allows mounting anywhere on shaft. Standard bushings cover a wide range of shaft sizes.

Packaged Design

No assembly required. Insert bushing for proper shaft size, slide on shaft and bolt down torque arm.

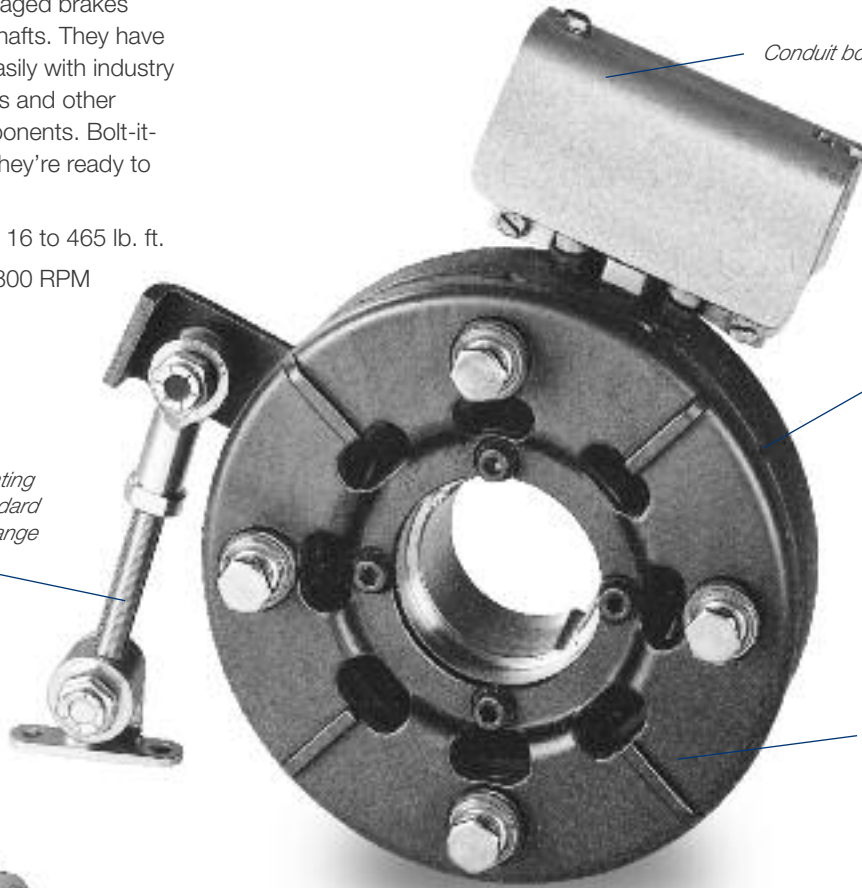

Typical Application



An Electro Brake mounted on a through shaft.

Horsepower vs. Shaft Speed

HP	SHAFT SPEED AT BRAKE (IN RPM)																				
	100	200	300	400	500	600	700	800	900	1000	1100	1200	1500	1800	2000	2400	3000	3600	4000	4500	5000
1/12																					
1/8																					
1/6																					
1/4																					
1/3																					
1/2																					
3/4																					
1																					
1-1/2																					
2																					
3																					
5																					
7-1/2																					
10																					
15																					
20																					
25																					
30																					
40																					
50																					
60																					
75																					

Selection/Ordering Information

Part Numbers

For Electro Brakes specifying a bushing, they need to be ordered separately. Please find specific bushing part numbers on pages 198 and 199 corresponding to the type of bushing indicated below and the required bore size.

Model Size	Bore Size or Bore Range & Bushing	Voltage DC	Part No.
EB-375	1/2"	6	5380-170-005
		24	5380-170-006
		90	5380-170-004
	5/8"	6	5380-170-003
		24	5380-170-007
		90	5380-170-002
	3/4"	6	5370-170-013
		24	5370-170-014
		90	5370-170-012
EB-475	1/2" to 1" Dodge 1008	6	5381-170-003
		24	5381-170-004
		90	5381-170-002
EB-650	1/2" to 1-3/8" Dodge 1310	6	5382-170-003
		24	5382-170-005
		90	5382-170-002
EB-825	1/2" to 1-1/2" Browning H	6	5383-170-002
		24	5383-170-004
		90	5383-170-005
EB-1000	1/2" to 1-5/8" Dodge 1615	6	5384-170-003
		24	5384-170-005
		90	5384-170-002
EB-1225	1/2" to 2-12" Dodge 2517	6	5385-170-003
		24	5385-170-005
		90	5385-170-002

Note: EB-375 also available in some metric bores.
EB-475-1225 use bushings which are available in metric bores.

Bore Sizes and Keyway

Size	Bore Dia.	Keyway
375	.501/.500	1/8 x 1/16
	.626/.625	3/16 x 3/32
	.751/.750	3/16 X 3/32
475 Through 1225	See bushing information on pages 198-199	

For Service Parts:

See pages 276-281.

For Motor Mounting:

See page 79 for adapter requirements.

EB Series Electro Brake

EB-375, EB-475, EB-650

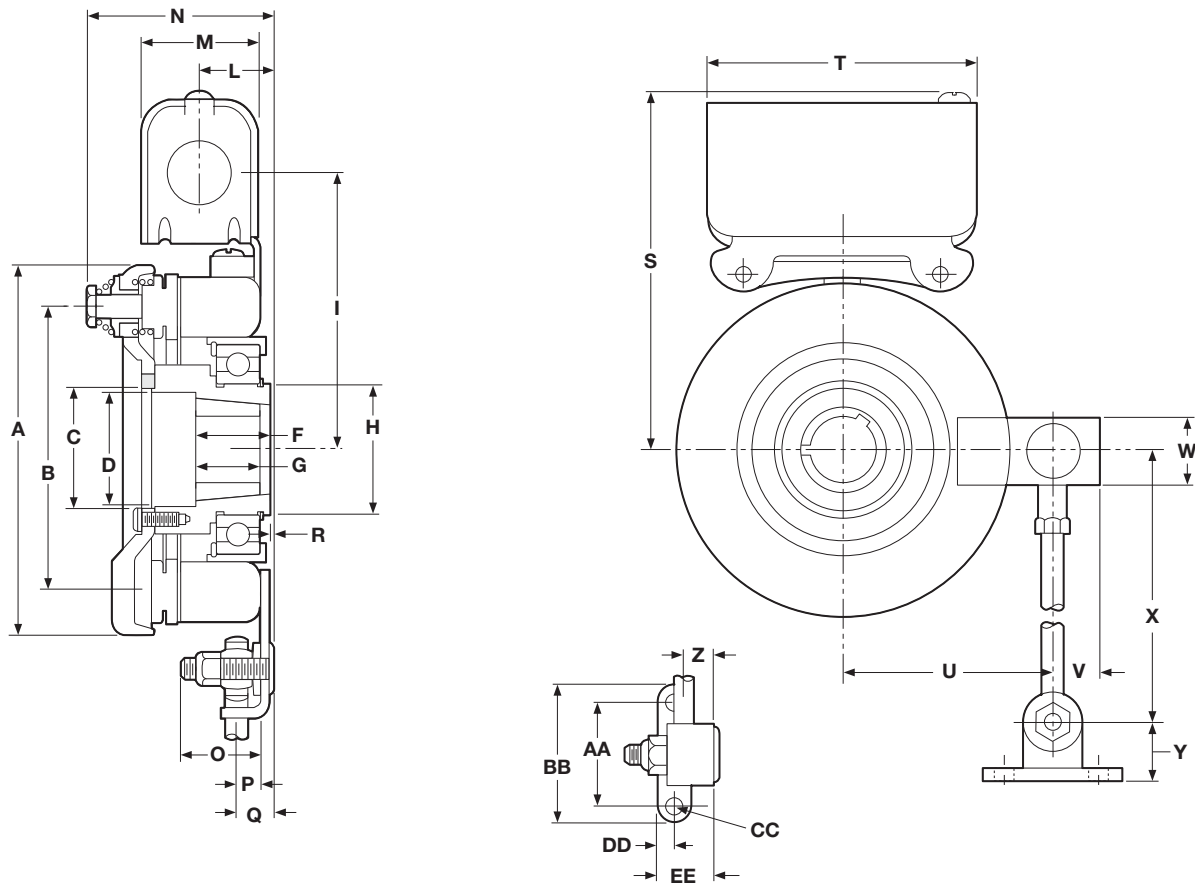

Dimensions

All dimensions are nominal, unless otherwise noted.

Size	A Max.	B Dia.	C Min.	D Dia.	E	F	G	H Dia.	I	J	K	L	M	N Max.	O
375	4.078	3.125	.7505	-	.031	1.656	-	1.375	3.344	10-32 UNF -3A x 1/4	.188	1.047	1.547	2.438	.844
475	5.172	4.000	1.663	1.594	-	1.000	1.000	1.781	3.875	-	-	.986	1.547	2.922	1.094
650	6.578	5.125	2.343	2.281	-	1.313	1.000	2.563	4.656	-	-	.986	1.547	3.109	1.031

Size	P	Q	R	S Max.	T	U	V	W	X	Y	Z	AA	BB	CC	DD	EE
375	.281	.625	.094 Min.	4.453	3.750	2.453	.666	1.000	8.000	.635	.359	1.500	2.000	.270 .260	.250	.781
475	.313	.531	.125 Max.	4.984	3.750	3.093	.697	1.000	10.000	.635	.391	1.500	2.000	.270 .260	.250	.781
650	.344	.641	.203 Max.	5.766	3.750	4.063	.843	1.125	11.000	.635	.438	1.500	2.000	.270 .260	.250	.781

Specifications

Model Size	Voltage DC	Static Torque (lb. ft.)	Max. Speed RPM	Inertia-WR ² (lb. ft ²)		Total Weight lbs.
				Arm. & Carrier	Hub	
EB-375	6, 24, 90	16	5000	.010	.001	4
EB-475	6, 24, 90	30	4500	.072	.006	7
EB-650	6, 24, 90	95	3600	.106	.010	11.3

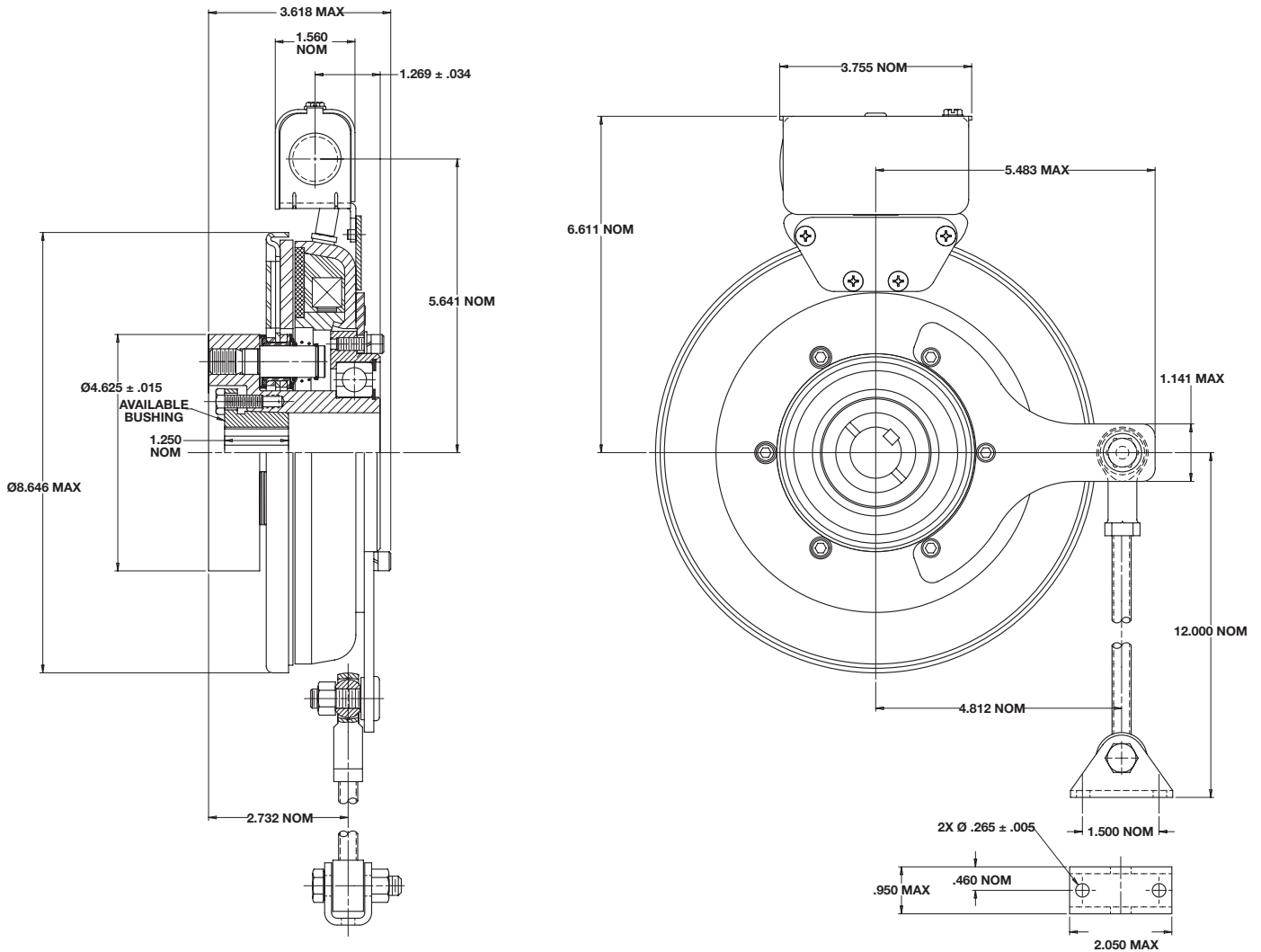

Specifications

Model Size	Voltage DC	Static Torque lb. ft.	Max. Speed RPM	Inertia-WR ² (lb. ft ²) Arm. & Hub	Total Weight lbs.
EB-825	6, 24, 90	125	3600	.459	20

EB Series Electro Brake

EB-1000, EB-1225

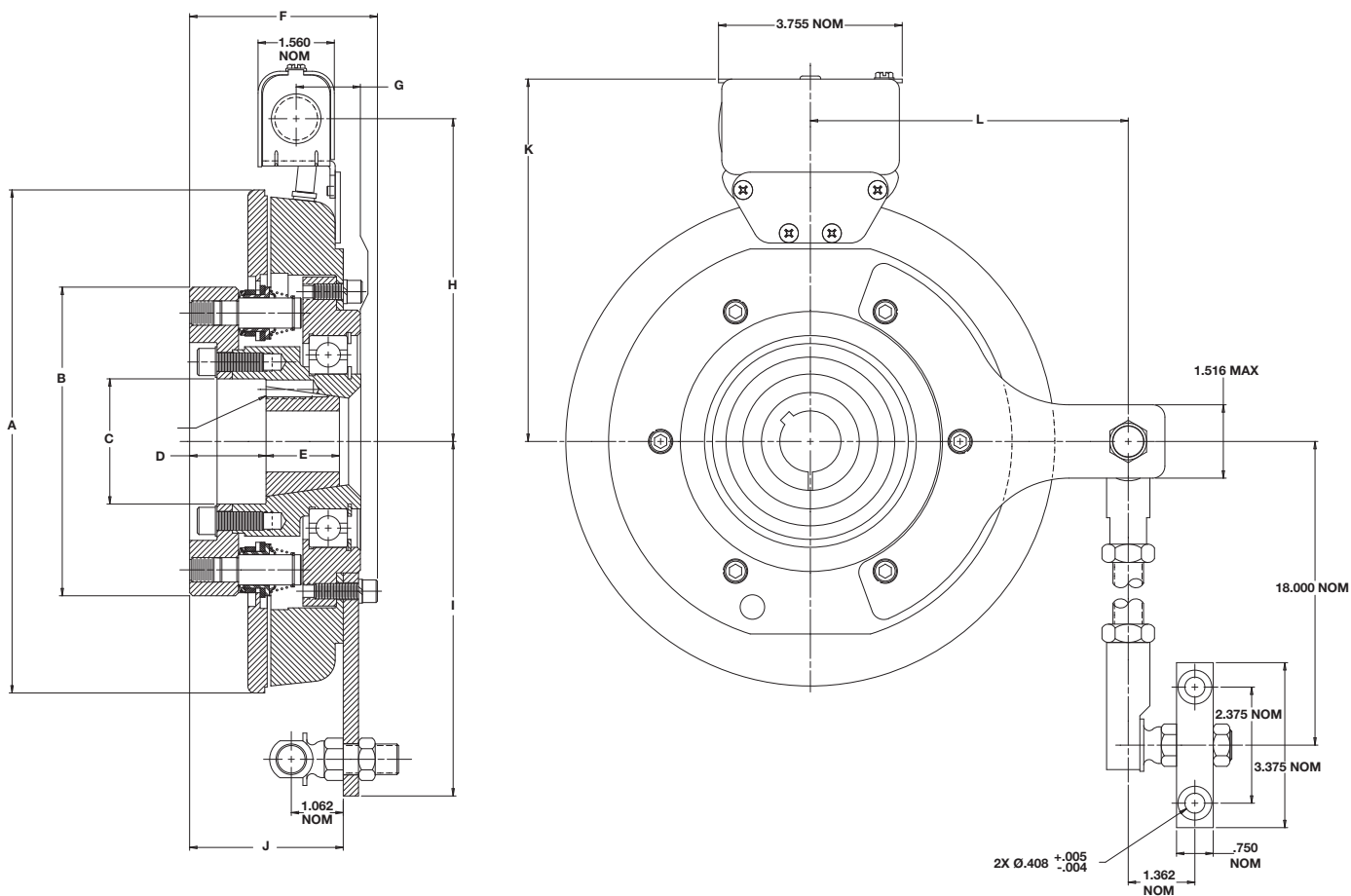

For thru-shaft mounting, specify bore size. Order bushing separately.
For motor mounting, order adapter separate (see page 79).

Dimensions

All dimensions are nominal, unless otherwise noted.

Size	A Max.	B Max.	C Min.	D	E	F Max.	G	H	I	J	K	L
1000	10.318	6.328	2.558	1.563	1.500	3.891	1.308	6.515	7.265	3.141	7.411	6.500
1225	12.703	6.953	3.390	.875	1.750	4.082	1.176	7.620	8.000	3.322	8.481	7.250

Specifications

Model Size	Voltage DC	Static Torque lb. ft.	Max. Speed RPM	Inertia-WR ² (lb. ft ²)		Total Weight lbs.
				Arm. & Hub	Hub	
EB-1000	6, 24, 90	240	2000	.720	.129	35.5
EB-1225	6, 24, 90	465	2000	1.8	.129	52.5

Optional Motor Shaft Adapter

Ten motor shaft adapters are available as an option for mounting Electro-Brakes on single shaft extension motors. For double shaft extension motors the adapter can be eliminated. A standard sheave, pulley, or sprocket, with either a tapered bushing or straight bore, can be installed on the shaft adapter. The Electro Brake is mounted on the end of the shaft adapter and the complete assembly fits onto the motor shaft and is secured with setscrews. Fitting the belts or chain and attaching the torque arm completes the installation.

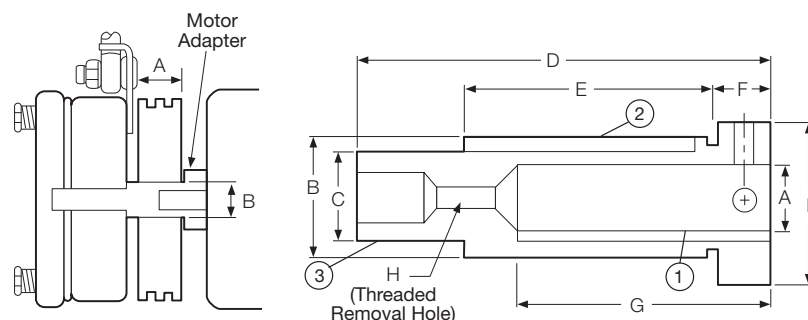

Dimensions

All dimensions are nominal, unless otherwise noted.

Model	A	Kwy.	Key Part No. ①	B	Kwy.	Key Part No. ②	C	Kwy.	Key Part No. ③	Dodge Bushing Size	D	E	F	G	H	I
EB-375	5/8	3/16x 3/32	*	7/8	3/16x 3/32	590-0016	5/8	3/16x 3/32	590-0043	None	4.391 4.359	2	.391 .359	2	1/4-20 UNC	1.125
EB-375	7/8	3/16x 3/32	*	1-1/4	1/4x 1/8	590-0022	5/8	3/16x 3/32	590-0043	None	4.578 4.742	2-1/4	.516 .484	2-1/4		1.500
EB-475	1-1/8	1/4x 1/8	*	1-5/8	3/8x 3/16	590-0041	1	1/4x 1/8	**	#1008 1"	4.516 4.484	2-3/4	.641 .609	2-3/4	1/2-13 UNC	1.750
EB-650	1-3/8	5/16x 5/32	*	2	1/2x 1/4	590-0042	1-3/8	5/16x 5/32	590-0044	#1310 1-3/8"	5.547 5.515	3-3/8	.641 .609	3-3/8	1/2-13 UNC	2.125
EB-650	1-5/8	3/8x 3/16	*	2-1/4	1/2x 1/4	590-0042	1-3/8	5/16x 5/32	590-0044	#1310 1-3/8"	6.172 6.140	4	.641 .609	4		2.375
EB-1000	1-5/8	3/8x 3/16	*	2-15/16	3/4x 7/16	590-0052	1-5/8	3/8x 7/32	**	#1615 1-5/8"	8.297 8.265	5-1/4		5	3/4-10 UNC	2.937
EB-1000	1-7/8	1/2x 7/32	*	2-15/16	3/4x 7/16	590-0052	1-5/8	3/8x 7/32	**	#1615 1-5/8"						2.937
EB-1000	2-1/8	1/2x 1/8	590-0062	2-15/16	3/4x 5/16	590-0069	1-5/8	3/8x 7/32	**	#1615 1-5/8"						2.937
EB-1225	2-1/8	1/2x 7/32	*	3-3/4	7/8x 7/16	590-0049	2-1/8	1/2x 9/32	590-0048	#2517 2-1/8"	10.672 10.640	7-1/4		6-7/8	7/8-9 UNC	3.750
EB-1225	2-3/8	5/8x 9/32	*	3-3/4	7/8x 7/16	590-0049	2-1/8	1/2x 9/32	590-0048	#2517 2-1/8"						3.750

*Standard Square Key Furnished with Motor.

**Special Key Furnished with Bushing.

Note: For adapter part numbers, see Service Parts beginning on page 276.