

Shaft Mounted Clutches

Warner Electric's packaged stationary field clutches are factory assembled and burnished to deliver the maximum rated torque immediately. In addition, a packaged product assures that all engineering factors regarding the proper alignment of components to one another have been established at the factory. This allows the unit to be 'slid on the shaft' after being shipped to you. The proper alignment of components is critical to achieving maximum torque and assuring long life.

Features

- No assembly required
- Anti-backlash armatures standard
- Ball bearing mounted field and armature hub
- Four sizes available
 - Size 180 – 15 in. lbs.
 - Size 250 – 70 in. lbs.
 - Size 325 – 125 in. lbs.
 - Size 400 – 270 in. lbs.



No brushes to wear out

Besides saving valuable assembly and run-in time, the SFP clutches incorporate an original Warner Electric concept. The concept of the stationary field eliminates the need for brushes. Brushes can be a high maintenance item in an electromagnetic clutch because of the mechanical friction seen at the collector ring. There is no mechanical friction with the stationary field design. In sum, all of the best possible features wrapped up into one compact package - **Warner Electric's SFP.**

Applications

- Packaging equipment
- Film readers
- Conveyors
- Medical equipment
- Sorting/feeding equipment

Functions

- Controlled, soft starts
- Speed variation
- High cycling

Shaft Mounted Clutches

Specifications

Model	Static Torque	Max.RPM
SFP-180	15 in.lb.	5000
SFP-250	70 in.lb.	7500
SFP-325	125 in.lb.	5000
SFP-400	270 in.lb.	5000

HP	SHAFT SPEED AT CLUTCH (IN RPM)																					
	100	200	300	400	500	600	700	800	900	1000	1100	1200	1500	1800	2000	2400	3000	3600	4000	4600	5000	
1/50																						
1/20																						
1/12															180							
1/8																						
1/6																						
1/4					325				250													
1/3																						
1/2																						
3/4																						
1																						
1-1/2																						
2																				400		
3																						

How to Order

1. Select the proper size from the chart (right).
2. Select the bore size and voltage.
3. Find the corresponding part number from the table below.
4. Select a Warner Electric Control if appropriate.

SFP-250

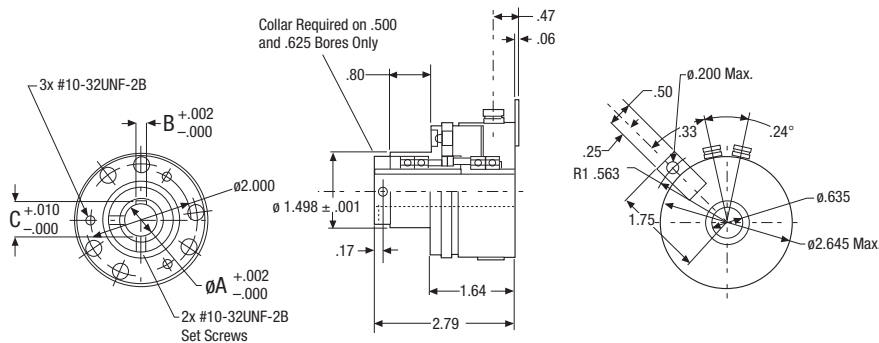

SFP-400

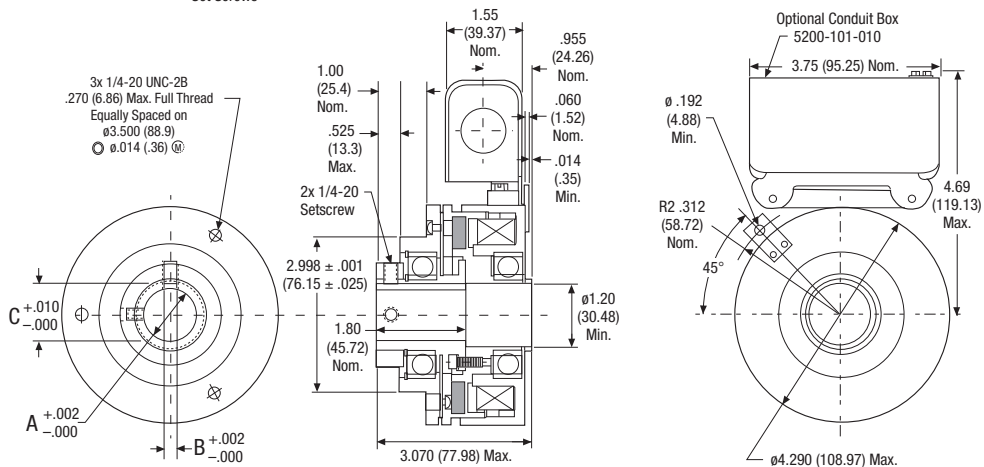

Tolerances

Model No.	A Bore	Keyway			Part Number		
		B	C	6V	24V	90V	
SFP-250	.375"	.0948	.421	5103-271-002	5103-271-006	5103-271-010	
	.438"	.126	.479	5103-271-003	5103-271-007	5103-271-011	
	.500"	.126	.560	5103-271-004	5103-271-008	5103-271-012	
	.6255"	.1885	.678	5103-271-005	5103-271-009	5103-271-013	
SFP-400	.5005"	.125	.560	5104-271-006	5104-271-016	5104-271-021	
	.6255"	.1875	.709	5104-271-007	5104-271-017	5104-271-022	
	.7505"	.1875	.837	5104-271-008	5104-271-018	5104-271-023	
	.8755"	.1875	.964	5104-271-009	5104-271-019	5104-271-024	
	1.0005"	.1875	1.090	5104-271-010	5104-271-020	5104-271-025	

Pre-Assembled SF Clutch For Parallel Shafts Model 180

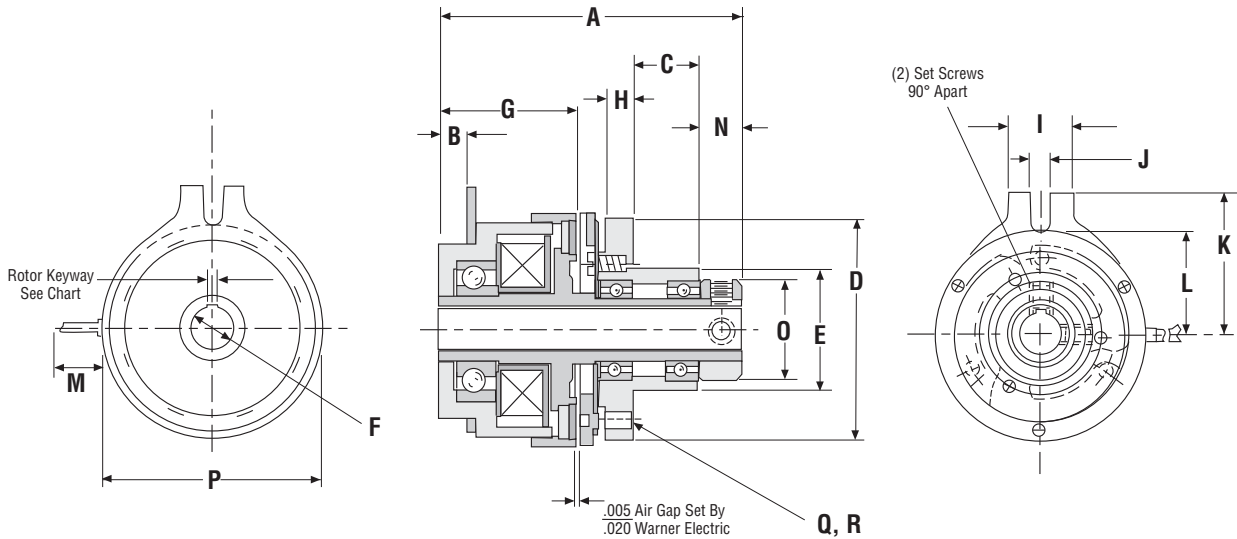

Dimensions

Model No.	A Max.	B Max.	C Nom.	D Max.	E ±.001	F Nom.	G Nom.	H Nom.	I Max.	J Min.	K Nom.	L Nom.	M ±.500	N Nom.	O Nom.	P Max.	Rotor Keyway			
																	Bore	Nominal Keyway	Q B.C.	R SIZE
180	2.515	.304	.500	1.755	.9985	$\frac{1}{4}$ $\frac{5}{16}$ $\frac{3}{8}$	1.290	.193	.505	.184	1.325	.975	12.00	.315	.875	1.620	N.A.	SET SCREWS ONLY	1.437 3-Holes	8-32 UNC-2B

Mechanical

Model No.	Static Torque lb. - in.	Inertia lb. - in. ²		Wt. oz.
		Rotor	Arm & Hub	
180	15	.052	.095	26

Electrical

Model No.	90 VDC		24 VDC	
	Amps	Ohms	Amps	Ohms
180	.066	1369	.289	83.1

Part Numbers

Model Size	Bore Size	Voltage DC	Part No.
180	1/4"	24	SFP180-14-24
	5/16"	24	SFP180-516-24
	3/8"	24	SFP180-38-24
	1/4"	90	SFP180-14-90
	5/16"	90	SFP180-516-90
	3/8"	90	SFP180-38-90

Customer shall maintain:

A loose-fitting pin through the anti-rotation tab to prevent preloading the bearings.

Pre-Assembled SF Clutch For Parallel Shafts
Model 325

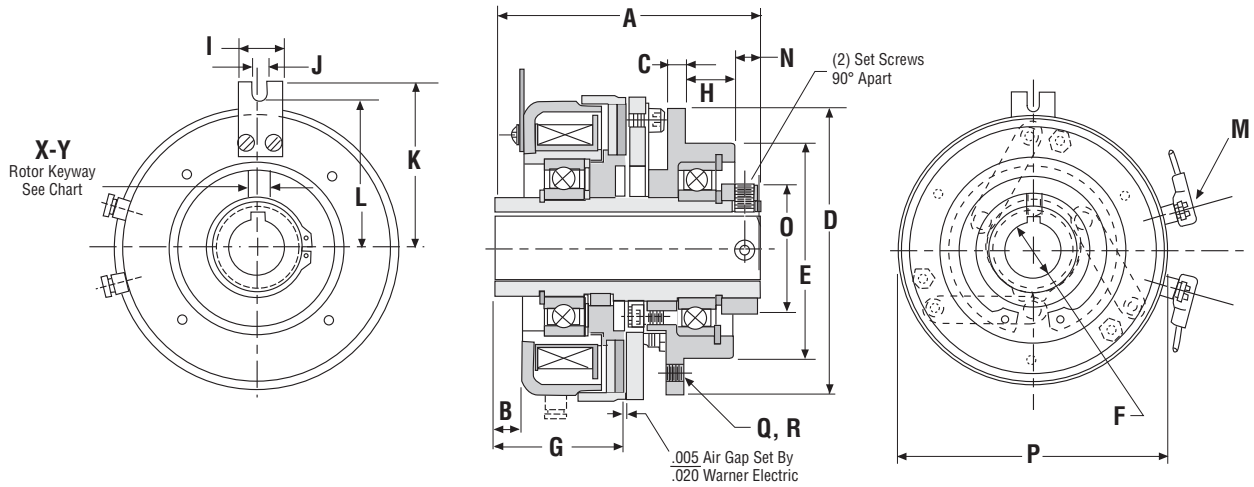

Dimensions

Model No.	A Max.	B Max.	C Nom.	D Max.	E ±.001	F Nom.	G Nom.	H Nom.	I Max.	J Min.	K Nom.	L Nom.	M ±.500	N Nom.	O Nom.	P Max.	Rotor Keyway		Q B.C.	R SIZE	
																	Nominal Keyway X*	Y*			
325	2.961	.140	.395	2.883	1.498	1/2	1.360	.500	.442	.170	2.050	1.740	Screw Terminals	.408	1.187	3.300	1/2	.125 - .128	.560 - .567	1.790 3-Holes	6-32 UNC-2B

*7/8 and 1 inch bore in rotor only.

Mechanical

Model No.	Static Torque lb. - in.	Inertia lb. - in. ²		
		Rotor	Arm & Hub	Wt. oz.
325	125	.560	.990	54

Electrical

Model No.	90 VDC		24 VDC	
	Amps	Ohms	Amps	Ohms
325	.091	988	.378	65.3

Lead wire is UL recognized style 1213, 1015 or 1430, 22 gage. Insulation is .0509 O.D. on 110 units; .0649 or .0959 O.D. on all other units.

Part Numbers

Model Size	Bore Size	Voltage DC	Part No.
325	1/2"	24	SFP325-12-24
	1/2"	90	SFP325-12-90

Customer shall maintain:

A loose-fitting pin through the anti-rotation tab to prevent preloading the bearings.