

Custom Design Clutches and Brakes

Mounting Examples and Options

Warner Electric custom design brakes and clutches are economical to purchase and simple to install. They consist of components which must be assembled on the shaft and properly attached to the machine frame.

Various customer furnished drive components must be assembled with the brake or clutch. Pulleys, sprockets and bearings/pillow blocks for shafting may be essential elements of a complete drive system. Squareness and concentricity tolerances are specified where critical to proper clutch/brake functioning.

The illustrations show SF, PC and PCB units mounted with customer supplied bearing mounted pulley. In each illustration the drive pin for a normal duty clutch is shown. In this manner the pulley will support the armature.

SF Clutches and SFC Clutch Couplings

Flange Mounting

Concentricity tolerances, held by customer, are critical. Pilot surfaces required on machine member. Eliminates bearings. Good design for high speed applications.

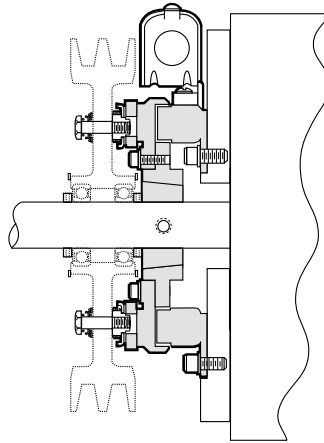
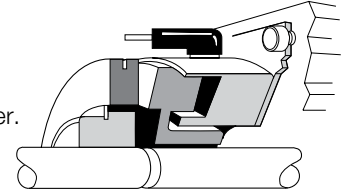

SF Clutch
Typical Installation

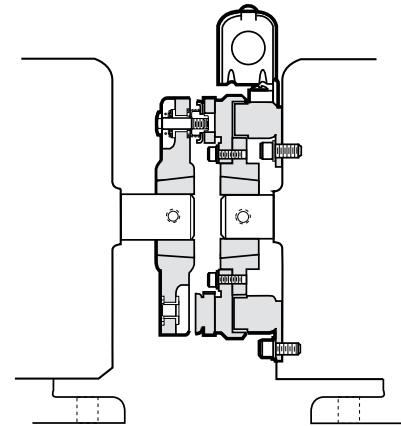

SFC Clutch Coupling
Typical Installation

Bearing Mounting

Bearing supports field and holds close tolerances required between rotor and field. Easy to install and priced about the same as the flange mounted design.

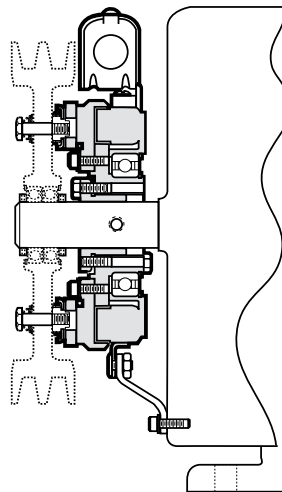
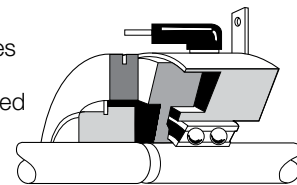

SF Clutch
Typical Installation

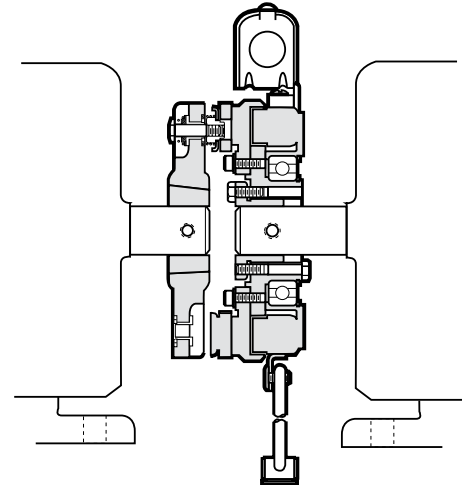

SFC Clutch Coupling
Typical Installation

Custom Design Clutches and Brakes

Mounting Examples and Options

PC Clutches and PCC Clutch Couplings

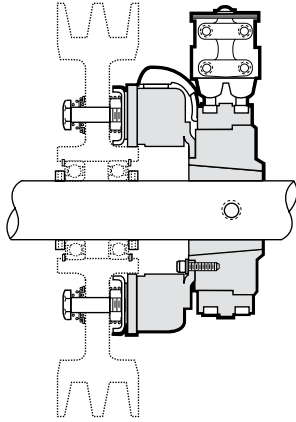

PC Clutch
Typical Installation
(Left hand hub shown)

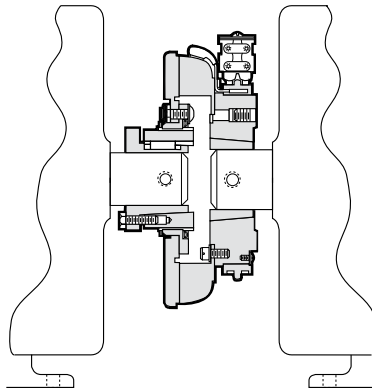

PCC Clutch Coupling
Typical Installation

Left Hand vs. Right Hand Hubs

Left handed or right handed Taperlock bushing installation

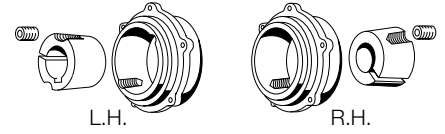

Taperlock bushing enters from magnet side. Mounting screws accessible from magnet size only.

Taperlock bushing enters from opposite side.

PB Brakes

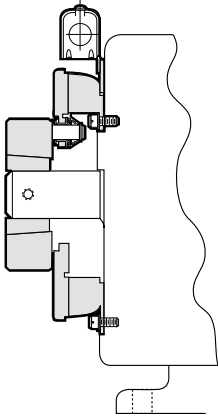

PB Brake
Typical Installation

Inside or Outside Mounting Option

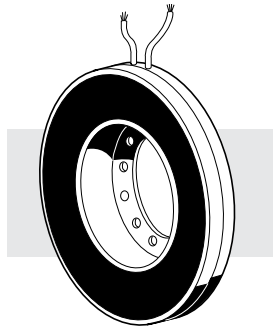

Inside Mount
Mounting screws for the magnet are accessible from inside the magnet only.

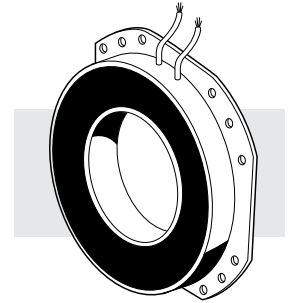

Outside Mount
Mounting screws for the magnet are accessible on the outside of the magnet. Outside mounted units cost slightly more.

Clutch/Brake Combinations

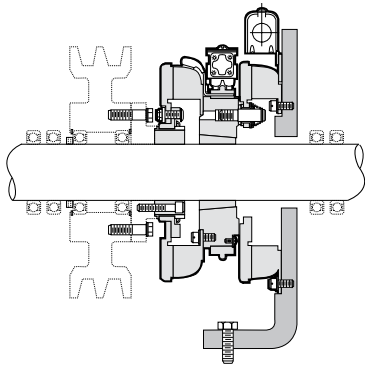

PCB Clutch/Brake
Typical Installation

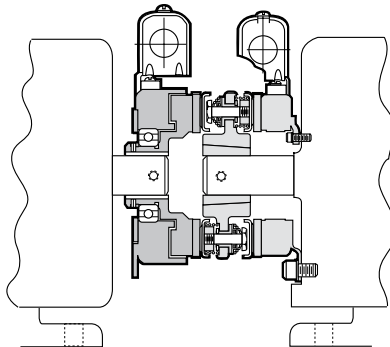

SFPBC Clutch/Brake Coupling
Typical Installation

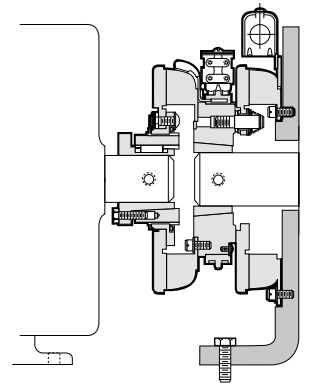

PCBC Clutch/Brake Coupling
Typical Installation