

PB Series Brake

PB-1000 Normal Duty

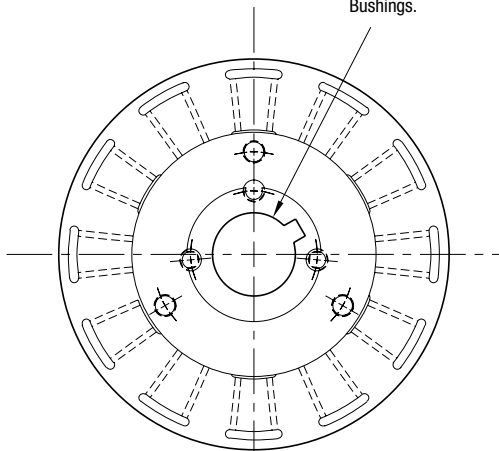

See page 252 for details on Bushings.



ARMATURE VIEW

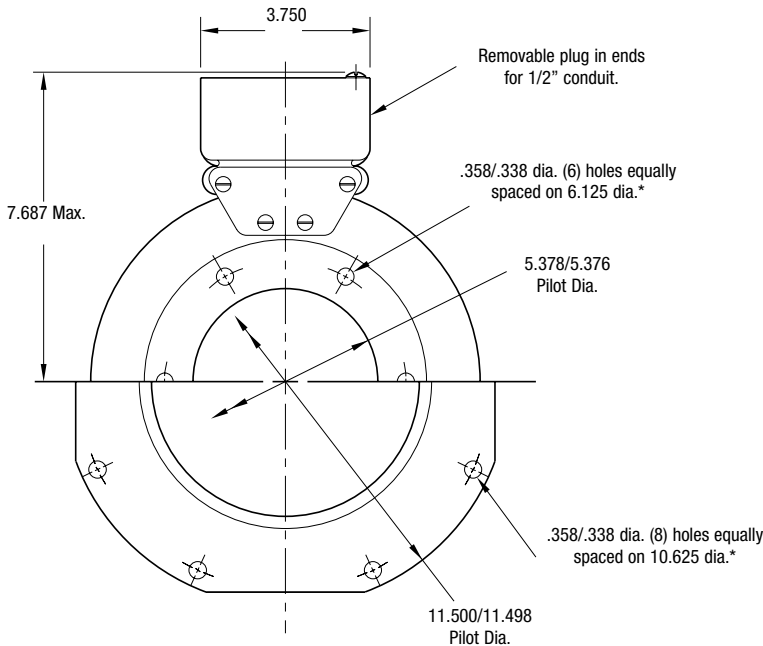

**MAGNET VIEW
(Inside & Outside Mounted)**

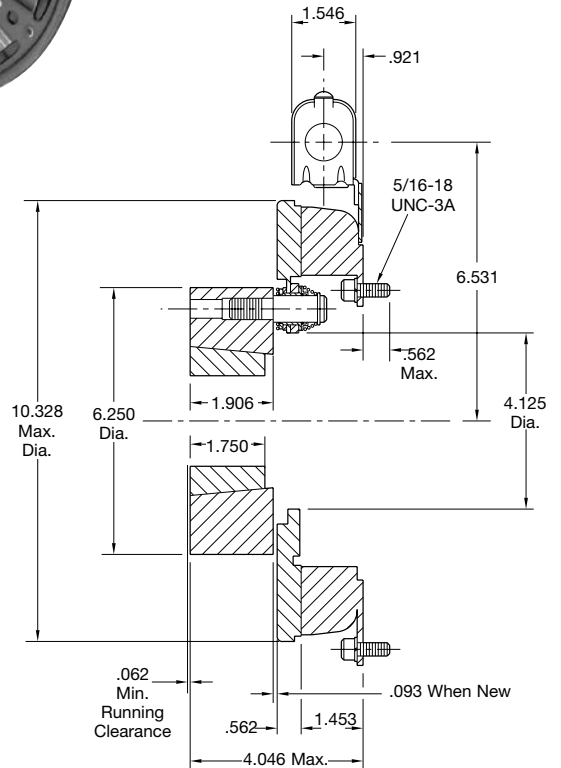

* Mounting holes are within .010 of true position relative to pilot diameter.

Shaft Size	.500 – 2.500
Static Torque	240 lb.ft.
Maximum Speed	3,600 rpm
Standard Voltage	D.C. 6, 24, 90

Customer Shall Maintain:

1. Squareness of magnet mounting face with armature shaft within .006 T.I.R.
2. Concentricity of magnet mounting pilot diameter with armature shaft within .010 T.I.R.

All dimensions are nominal unless otherwise noted.

Information on inertia and weights begins on page 239. Coil data is on pages 250 and 251.



PB-1000 Normal Duty

Drawing I-25586

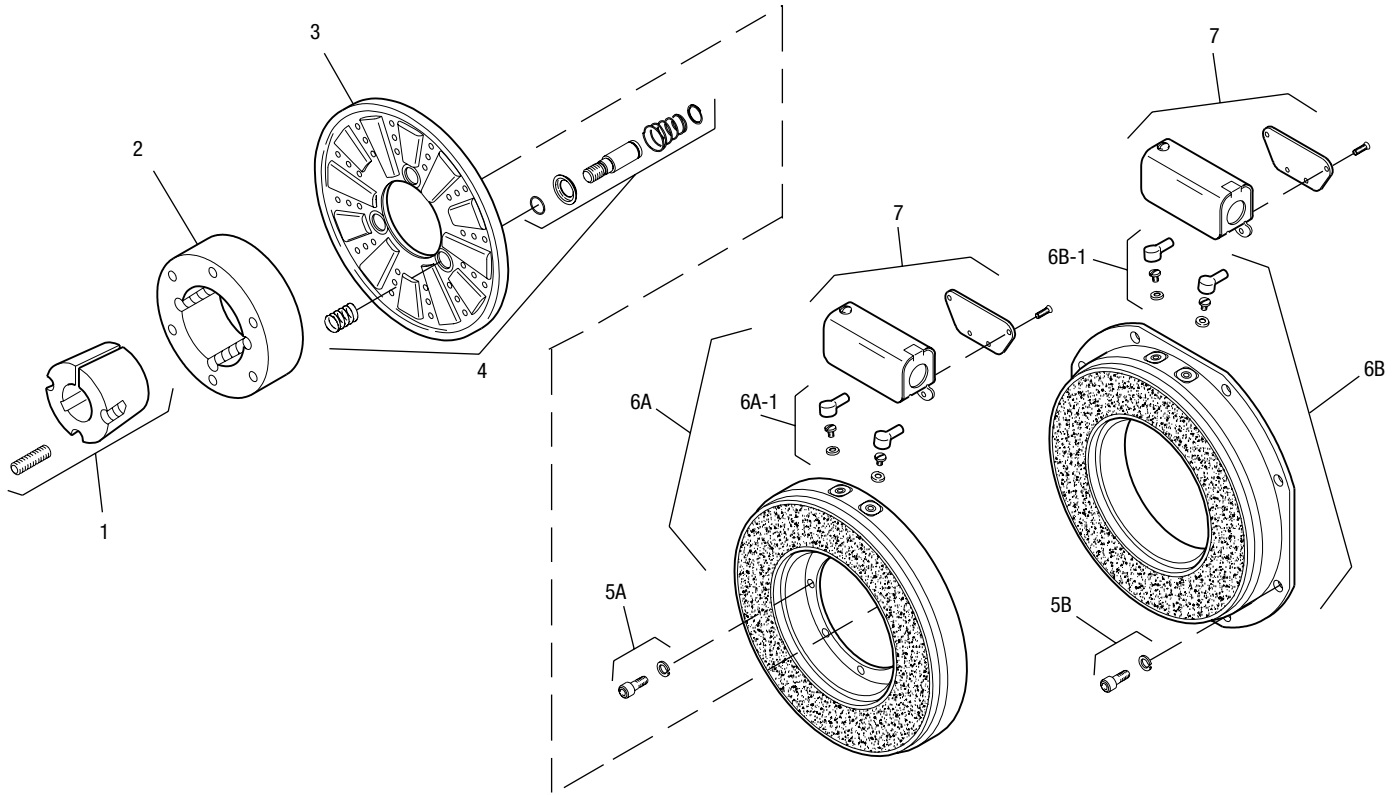

Item	Description	Part Number	Qty.
1	Bushing*		1
	1/2" to 2-1/2" Bore	180-0185 to 180-0217	
2	Armature Hub	540-0313	1
3	Armature	5302-111-013	1
4	Autogap Accessory	5201-101-008	3
5A	Mounting Accessory - I.M.	5321-101-001	1
5B	Mounting Accessory - O.M.	5321-101-002	2
6A	Magnet - Inside Mounted		1
	6 Volt	5312-631-004	
	24 Volt	5312-631-005	
	90 Volt	5312-631-006	
	†90 Volt LK Facing	5312-631-001	
6A-1	Terminal Accessory	5311-101-001	1
6B	Magnet, Outside Mounted		1
	6 Volt	5312-631-011	
	24 Volt	5312-631-013	
	90 Volt	5312-631-012	
	†90 Volt LK Facing	5312-631-002	

Item	Description	Part Number	Qty.
6B-1	Terminal Accessory	5311-101-001	1
7	Conduit Box	5200-101-011	1

How to Order:

1. Specify Bore Size for Item 1.
2. Specify Inside Mounted for Items 5A and 6A or Outside Mounted for Items 5B and 6B.
3. Specify Voltage for Item 6A or 6B.
4. See Controls Section.

Example:

PB-1000 Brake per I-25586 - 90 Volt, Inside Mounted, 1" Bore

These units, when used in conjunction with the correct Warner Electric conduit box, meet the standards of UL508 and are listed under guide card #NMTR, file #59164. These units are CSA certified under file #LR11543.

*See page 252 for specific part numbers.

Refer to Service Manual P-0208-WE

†Optional LK facing available. For more information, see page 232.