

PB Series Brake

PB-120

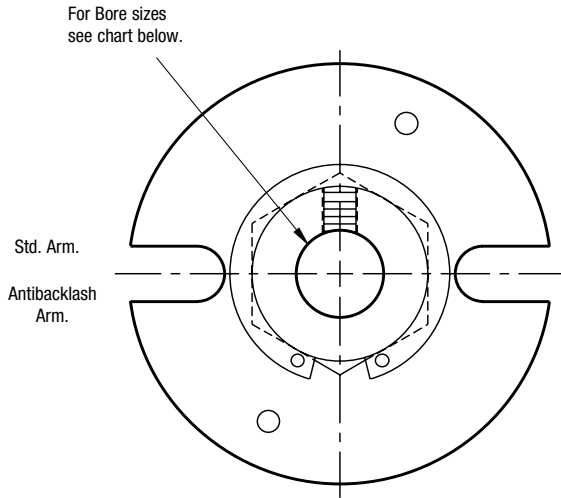

ARMATURE VIEW

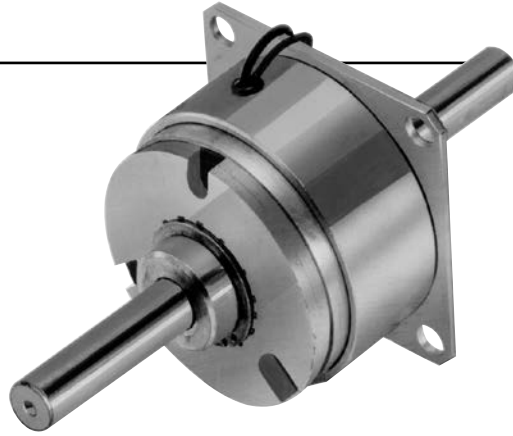
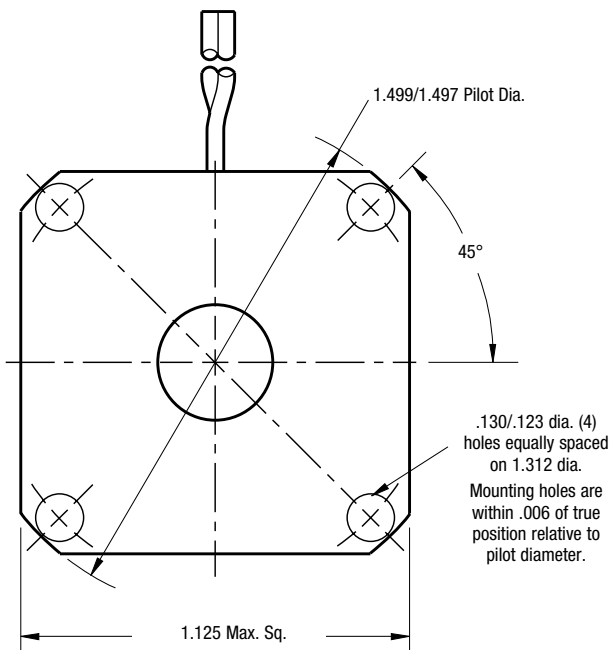

MAGNET VIEW

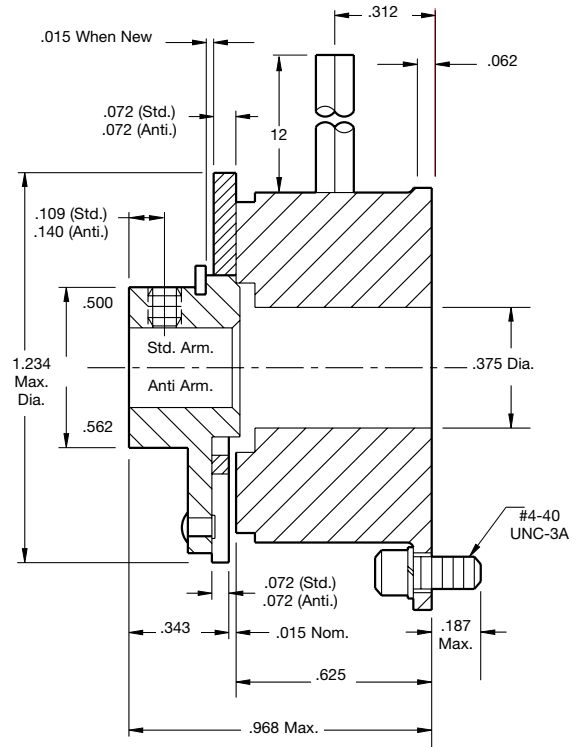

Bore Dimensions

Armature Bore Dia.
.188/.187
.251/.250
(.313/.312)*

*(Antibacklash Armatures)

Static Torque	5 lb.in.
Maximum Speed	10,000 rpm
Standard Voltage	D.C. 6, 24, 90

All dimensions are nominal unless otherwise noted.

Information on inertia and weights begins on page 239. Coil data is on pages 250 and 251.



Drawing I-25507

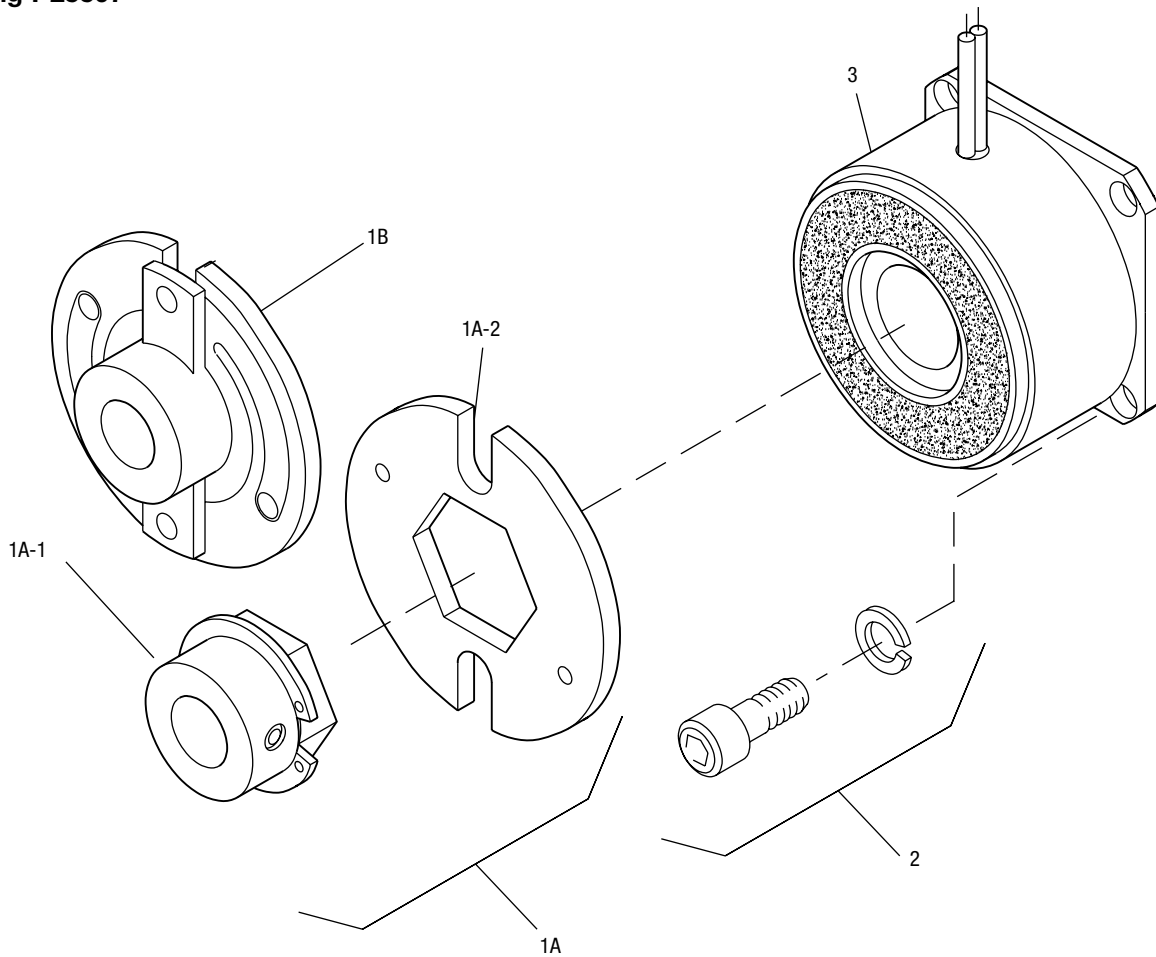

Item	Description	Part Number	Qty.
1A	Armature and Hub		
1A-1	Armature Hub		1
	3/16" Bore	5622-541-009	
	1/4" Bore	5622-541-008	
1A-2	Armature	110-0110	1
1B	Antibrake Armature		1
	3/16" Bore	5622-111-004	
	1/4" Bore	5622-111-002	
	5/16" Bore	5622-111-003	
2	Mounting Accessory	5101-101-001	1
3	Magnet		1
	6 Volt	5373-631-003	
	24 Volt	5373-631-005	
	90 Volt	5373-631-007	

How to Order:

1. Specify Type of Armature Desired.
2. Specify Bore Size for Item 1A-1 or 1B.
3. Specify Voltage for Item 3.
4. See Controls Section.

Example:

PB-120 Brake per I-25507 - 90 Volt, Standard Armature 3/16" Hub Bore

These units meet the standards of UL508 and are listed under guide card #NMTR, file #59164.

These units are CSA certified under file #LR11543.

Refer to Service Manual P-0201-WE