

# PCB Series Clutch/Brake

## PCB-1525/1225 Normal Duty

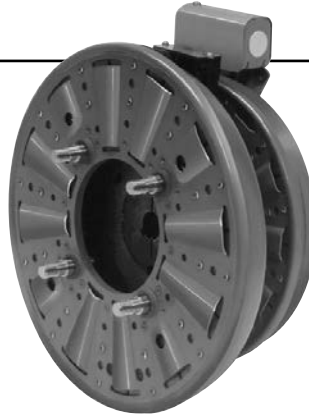

See page 252 for details on Bushings.

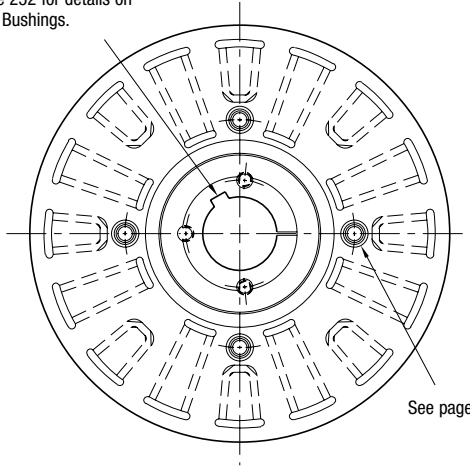

See page 230 for details on Drive Pin mountings.

**ARMATURE VIEW**

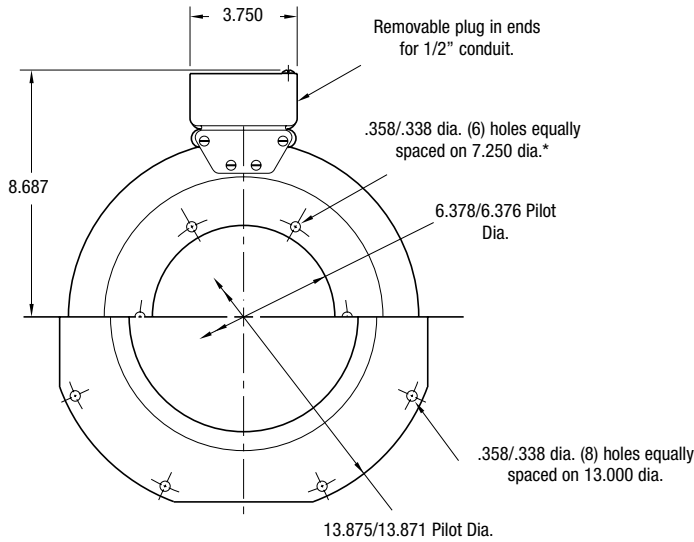

**MAGNET VIEW  
(Inside & Outside Mounted)**

**Customer Shall Maintain:**

1. Concentricity of brake mounting pilot diameter with mounting shaft within .010 T.I.R.
2. Squareness of brake magnet mounting face with mounting shaft within .006 T.I.R. measured at magnet mounting bolt circle.

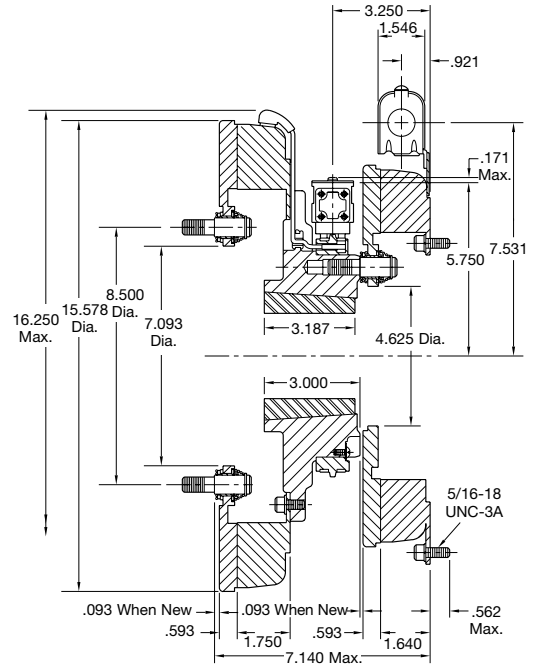

\* Mounting holes are within .010 of true position relative to pilot diameter.

Shaft Size	.937 – 3.000
Static Torque Clutch	700 lb. ft.
Static Torque Brake	465 lb. ft.
Maximum Speed	2,000 rpm
Standard Voltage	D.C. 6, 24, 90

All dimensions are nominal unless otherwise noted.

Information on inertia and weights begins on page 239. Coil data is on pages 250 and 251.



## PCB-1525/1225 Normal Duty

Drawing I-25635

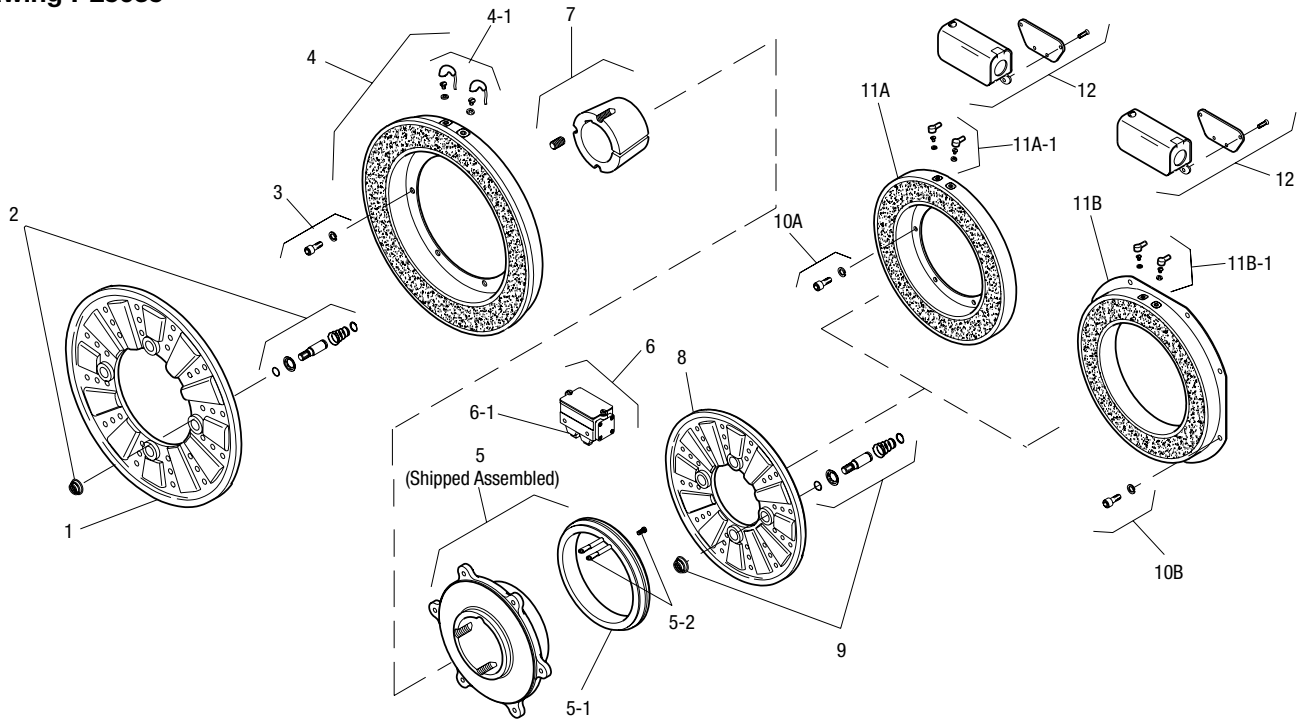

Item	Description	Part Number	Qty.
1	Armature	5304-111-004	1
2	Autogap Accessory	5201-101-008	4
3	Mounting Accessory	5321-101-001	1
4	Magnet		1
	6 Volt	5304-631-009	
	24 Volt	5304-631-011	
	90 Volt	5304-631-010	
	†90 Volt LK Facing	5304-631-002	
4-1	Terminal Accessory	5311-101-001	1
5	Magnet Hub		1
	Left Hand (shown)	5304-541-001	
	Right Hand	5304-541-002	
5-1	Collector Ring	5301-749-001	1
5-2	Collector Ring Accessory	5304-101-004	1
6	Brushholder	5300-178-001	1
6-1	Brush	176-0001	4
7	Bushing*		1
	15/16" to 3" Bore	180-0262 to 180-0295	
8	Armature	5303-111-009	1
9	Autogap Accessory	5201-101-008	4
10A	Mounting Assembly - I.M.	5321-101-001	1
10B	Mounting Accessory - O.M.	5321-101-002	2
11A	Magnet - Inside Mounted		1
	6 Volt	5313-631-005	
	24 Volt	5313-631-006	
	90 Volt	5313-631-007	
	†90 Volt LK Facing	5313-631-001	

Item	Description	Part Number	Qty.
11A-1	Terminal Accessory	5311-101-001	1
11B	Magnet - Outside Mounted		1
	6 Volt	5313-631-010	
	24 Volt	5313-631-012	
	90 Volt	5313-631-011	
	†90 Volt LK Facing	5313-631-002	
11B-1	Terminal Accessory	5311-101-001	1
12	Conduit Box	5200-101-010	1

### How to Order:

1. Specify Voltage for Item 4 and Item 11A or 11B.
2. Specify left hand or right hand hub for Item 5. Bushing enters from magnet side for L.H. hub and from hub side for R.H.
3. Specify Bore Size for Item 7.
4. Specify Inside Mounted for Items 10A and 11A or Outside Mounted for Items 10B and 11B.
5. See Controls Section.

### Example:

PCB-1525/1225 Clutch Brake per I-25635 - 90 Volt, Left Hand hub, 2" Bore, Inside Mounted

These units meet the standards of UL508 and are listed under guide card #NMTR2, file #59164. These units are CSA certified under file #LR11543.

\*See page 252 for specific part numbers.

Refer to Service Manual P-0214-WE

†Optional LK facing available. For more information, see page 232.