

PCBC Series Clutch/Brake Coupling

PCBC-500 Heavy Duty

1/2-14 NPSM Am. std. straight pipe tap.

See page 252 for details on Bushings.

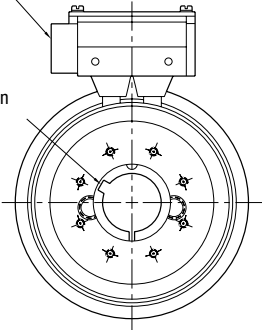

COLLECTOR RING VIEW

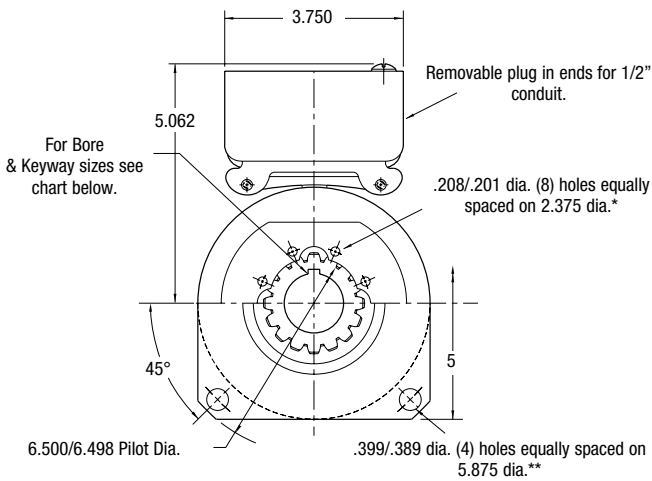
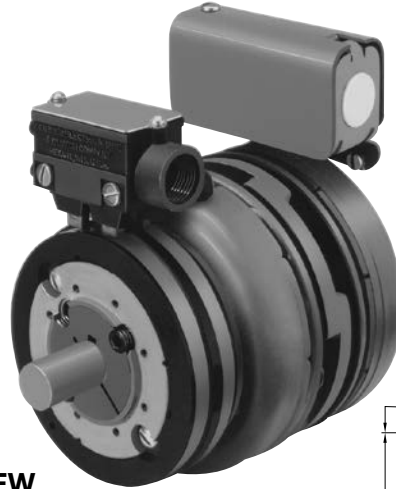

MAGNET VIEW

* Mounting holes are within .010 of true position relative to pilot diameter.

** Mounting holes are within .008 of true position relative to pilot diameter.

Bore and Keyway Dimensions

Armature Bore Dia.	Keyway
.751/.750	.187 x .093
.876/.875	
.9385/.9375	.250 x .125
1.001/1.000	
1.126/1.125	
1.251/1.250	

Customer Shall Maintain:

1. Squareness of brake mounting face with armature hub shaft within .006 T.I.R.
2. Concentricity of brake mounting pilot diameter with armature hub shaft within .010 T.I.R.
3. Concentricity of clutch magnet hub assembly shaft with armature hub shaft within .006 T.I.R.

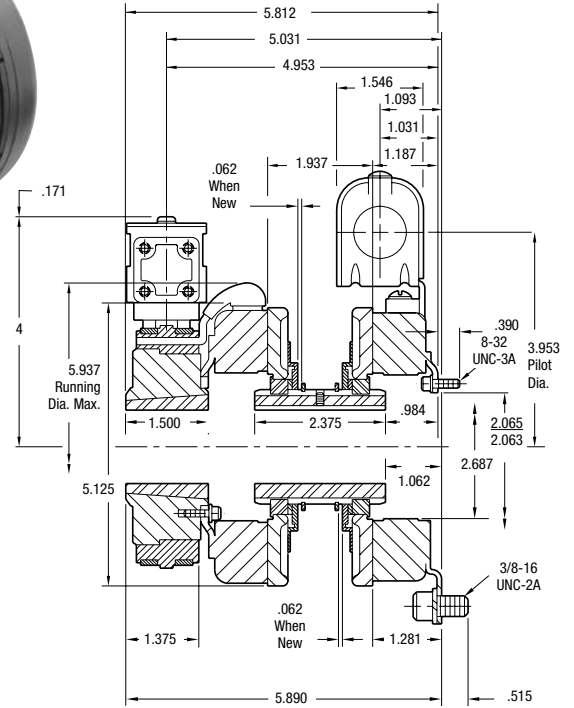

Outside Mounted Offset Backing Plate

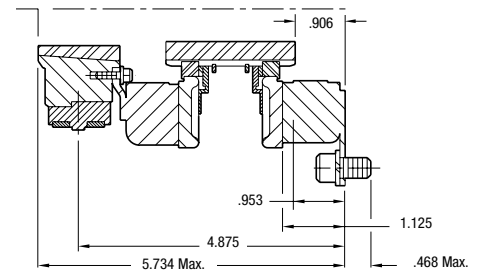

Outside Mounted Flush Backing Plate

Armature Shaft	.500 – 1.250
Magnet Shaft	.750 – 1.250
Static Torque	40 lb. ft.
Maximum Speed	5,400 rpm
Standard Voltage	D.C. 6, 24, 90

All dimensions are nominal unless otherwise noted.

Information on inertia and weights begins on page 239. Coil data is on pages 250 and 251.

PCBC Series Clutch/Brake Coupling

PCBC-500 Heavy Duty

Drawing I-25553

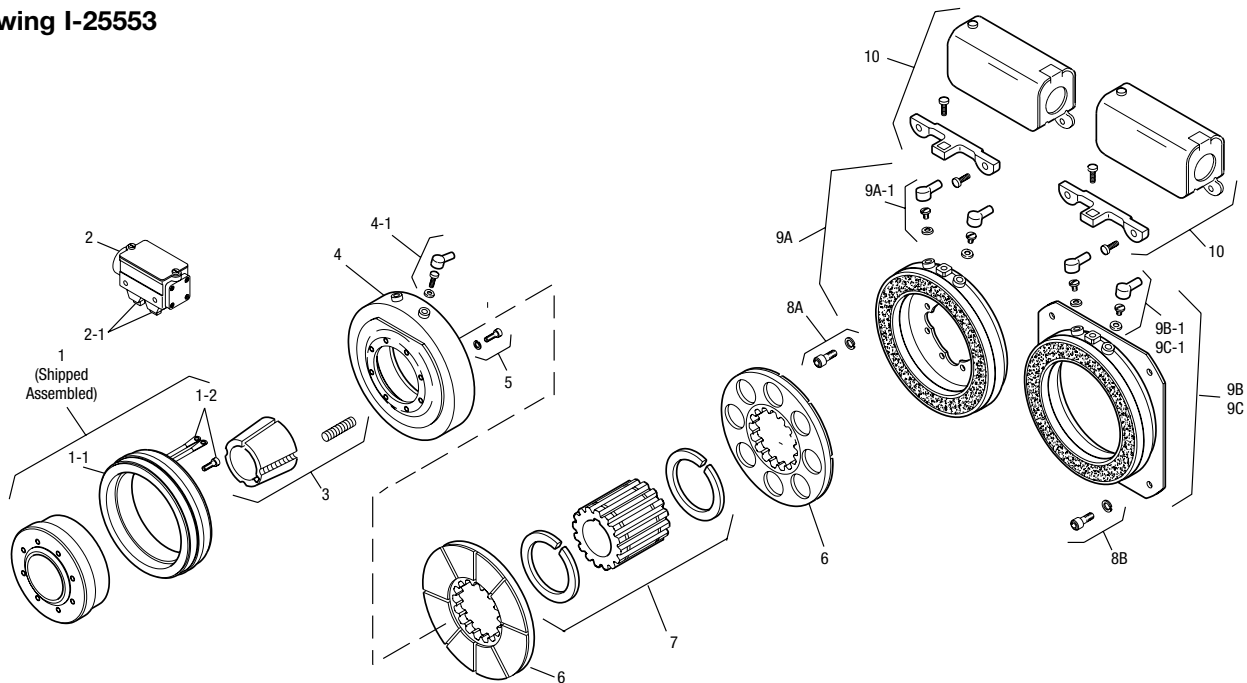

Item	Description	Part Number	Qty.
1	Magnet Hub	5300-541-001	1
1-1	Collector Ring	5300-749-001	1
1-2	Collector Ring Mounting Accessory	5300-101-002	1
2	Brushholder	5300-178-001	1
2-1	Brush	176-0001	4
3	Bushing*		1
	1/2" - 1-1/4" Bore	180-0116 to 180-0128	
4	Magnet, Clutch		1
	6 Volt	5300-631-002	
	24 Volt	5300-631-003	
	90 Volt	5300-631-005	
4-1	Terminal Accessory	5311-101-001	1
5	Mounting Accessory	5102-101-001	2
6	Armature	5230-111-002	2
7	Armature Hub		1
	Bore	Keyway	
	3/4"	3/16 x 3/32	5300-541-006
	7/8"	3/16 x 3/32	5300-541-007
	15/16"	1/4 x 1/8	5300-541-008
	1"	1/4 x 1/8	5300-541-009
	1-1/8"	1/4 x 1/8	5300-541-010
	1-1/4"	1/4 x 1/8	5300-541-011
8A	Mounting Accessory - I.M.	5102-101-001	2
8B	Mounting Accessory - O.M.	5300-101-008	1
9A	Magnet - I.M.		1
	6 Volt	5300-631-002	
	24 Volt	5300-631-003	
	90 Volt	5300-631-005	

Item	Description	Part Number	Qty.
9A-1	Terminal Accessory	5311-101-001	1
9B	Magnet - O.M. - Offset		1
	90 Volt	5300-631-014	
9B-1	Terminal Accessory	5311-101-001	1
9C	Magnet - O.M. - Flush		1
	6 Volt	5300-631-009	
	24 Volt	5300-631-010	
	90 Volt	5300-631-011	
9C-1	Terminal Accessory	5311-101-001	1
10	Conduit Box	5200-101-010	1

How to Order:

1. Specify Bore Size for Items 3 and 7.
2. Specify Voltage for Item 4 and Item 9A, 9B or 9C.
3. Specify Inside Mounted for Item 9A and Outside Mounted (Offset) for Item 9B or Outside Mounted (Flush) for Item 9C.
4. Specify Inside Mount for Item 8A or Outside Mount for Item 8B.
5. See Controls Section.

Example:

PCBC-500 Clutch Brake Coupling per I-25553 - 90 Volt, Outside Mounted Flush, 1" Bore

These units meet the standards of UL508 and are listed under guide card #NMTR2, file #59164. These units are CSA certified under file #LR11543.

*See page 252 for specific part numbers.

Refer to Service Manual P-0203-WE