

# PCBC Series Clutch/Brake Coupling

## PCBC-1225

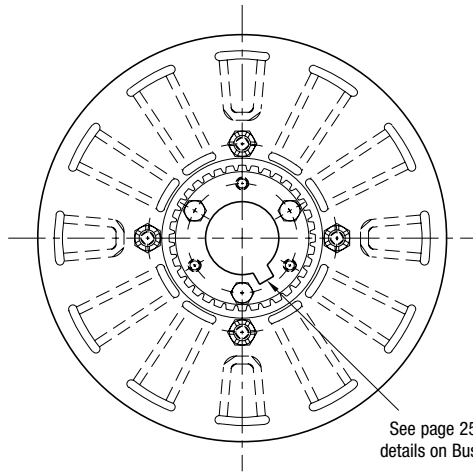
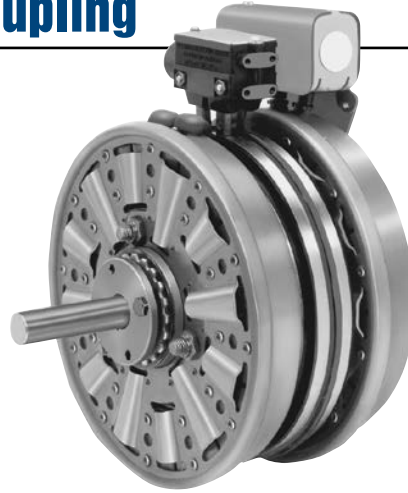

See page 252 for details on Bushings.

**ARMATURE VIEW**

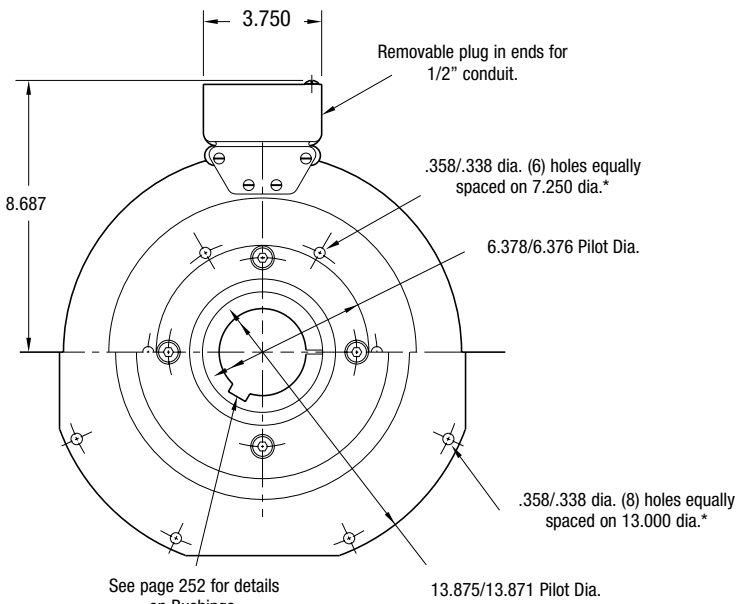

**MAGNET VIEW  
(Inside & Outside Mounted)**

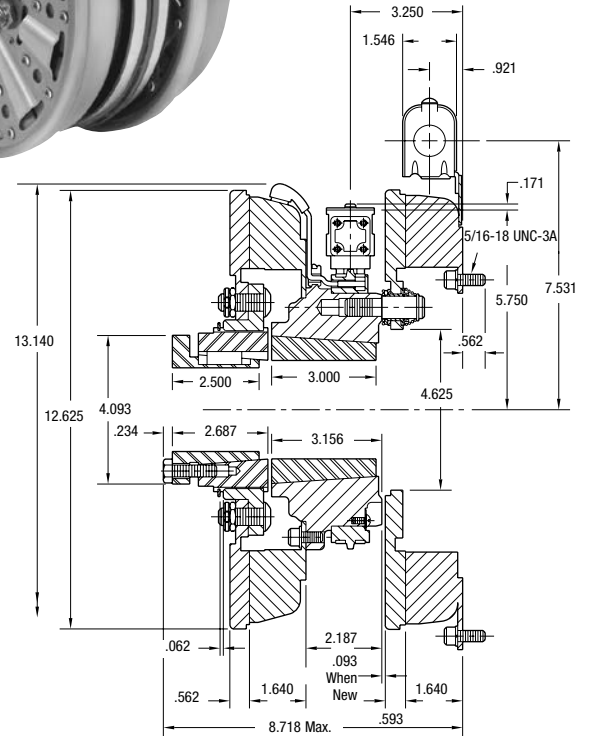

\* Mounting holes are within .010 of true position relative to pilot diameter.

### Customer Shall Maintain:

1. Armature mounting shaft concentric with magnet mounting shaft within .006 T.I.R.
2. Squareness of brake magnet mounting face with magnet mounting shaft within .006 T.I.R.
3. Concentricity of brake magnet mounting pilot diameter with magnet mounting shaft within .010 T.I.R.
4. Angular alignment of shafts within 1/2 degree.

Armature Shaft	.750 – 2.687
Magnet Shaft	.937 – 3.000
Static Torque	465 lb.ft.
Maximum Speed	3,000 rpm
Standard Voltage	D.C. 6, 24, 90

All dimensions are nominal unless otherwise noted.

Information on inertia and weights begins on page 239. Coil data is on pages 250 and 251.



# PCBC Series Clutch/Brake Coupling

## PCBC-1225

Drawing I-25612

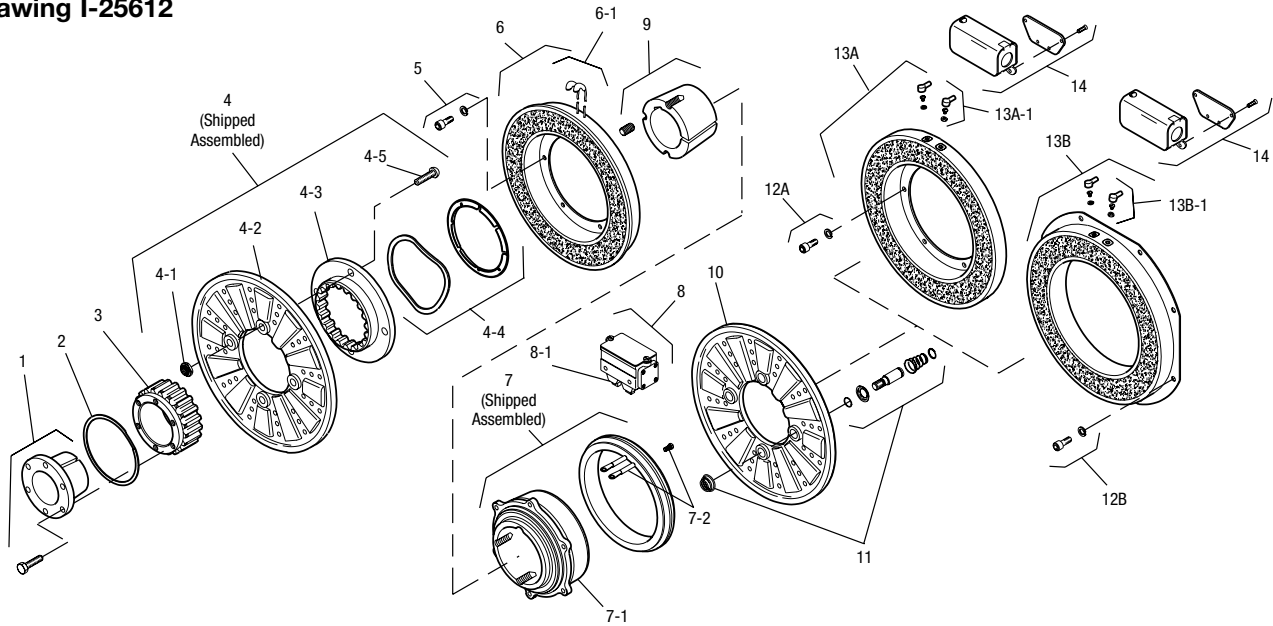

Item	Description	Part Number	Qty.
1	Bushing*		1
	3/4" to 2-11/16" Bore	180-0026 to 180-0057	
2	Retainer Ring	748-0005	1
3	Splined hub	540-0064	1
4	Armature & Splined Adapter	5323-111-001	1
4-1	Locknut	661-0005	4
4-2	Armature	5323-111-034	1
4-3	Splined Adapter	104-0010	1
4-4	Autogap Accessory	5323-101-002	1
4-5	Screw	797-0281	4
5	Mounting Accessory	5321-101-001	1
6	Magnet		1
	6 Volt	5303-631-005	
	24 Volt	5303-631-007	
	90 Volt	5303-631-008	
	†90 Volt LK Facing	5303-631-001	
6-1	Terminal Accessory	5311-101-001	1
7	Magnet Hub		1
	Left Hand (shown)	5303-541-001	
	Right Hand	5303-541-002	
7-1	Collector Ring	5301-749-001	1
7-2	Collector Ring Assembly	5303-101-004	1
8	Brushholder	5300-178-001	1
8-1	Brush	176-0001	4
9	Bushing*		1
	15/16" to 3" Bore	180-0262 to 180-0295	
10	Armature	5303-111-009	1
11	Autogap Accessory	5201-101-008	4
12A	Mounting Accessory - I.M.	5321-101-001	1
12B	Mounting Accessory - O.M.	5321-101-002	2

Item	Description	Part Number	Qty.
13A	Magnet - Inside Mounted		1
	6 Volt	5313-631-005	
	24 Volt	5313-631-006	
	90 Volt	5313-631-007	
	†90 Volt LK Facing	5313-631-001	
13A-1	Terminal Accessory	5311-101-001	1
13B	Magnet - Outside Mounted		1
	6 Volt	5313-631-010	
	24 Volt	5313-631-012	
	90 Volt	5313-631-011	
	†90 Volt LK Facing	5313-631-002	
13B-1	Terminal Accessory	5311-101-001	1
14	Conduit Box	5200-101-011	1

### How to Order:

1. Specify Bore Size for Items 1 and 9.
2. Specify Voltage for Items 6 and 13.
3. Specify left hand or right hand hub for Item 7. Bushing enters from magnet side for L.H. hub and from hub side for R.H.
4. Specify Inside Mounted for Items 12A and 13A or Outside Mounted for Items 12B and 13B.
5. See Controls Section.

### Example:

PCBC-1225 Clutch Brake Coupling per I-25612 - 90 Volt, Inside Mounted Left Hand hub, 1-3/4" Bore (Items 1 and 9)

These units meet the standards of UL508 and are listed under guide card #NMTR2, file #59164. These units are CSA certified under file #LR11543.

\*See page 252 for specific part numbers.

Refer to Service Manual P-0205-WE

†Optional LK facing available. For more information, see page 232.