

E210 VAR 00

Electro-Magnetic Single Disc Clutch

Characteristics

- Electrically operated 24 or 103,5 VDC depending size
- Single friction face
- Activated by power on

Utilisation

- Coupling of two shafts in line

Particularities

- No backlash
- For dry use
- No residual torque in disengaged position
- Fixed inductor mounted on ball bearings

Adjustments

- Airgap "P" should be adjusted at installation
- Does not require wear compensation

Maintenance Manual

- SM 307

Mounting Precautions

- The anti-rotation device of the electromagnet shall be inserted in anti rotation slot, with a side play of 0,5 mm and a 1 mm play to the bottom. This avoids a normal stress on the ball-bearings.
- We strongly recommend to mount a damping elastic slot in the anti-rotation device in case of vibrations
- Device intended for horizontal use; for vertical use, please consult the factory

Power Supply

- For sizes until 1600 :
CBC 400-24 - CBC 450-24
CBC 500-24 - CBC 550-24
CBC 140-5 + CBC 140-T
- For size 3200:
CBC 140-5

Mounting Example

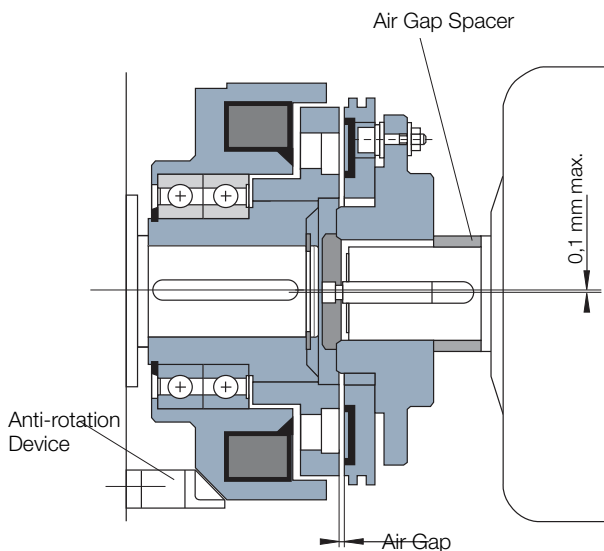

Heat Dissipation

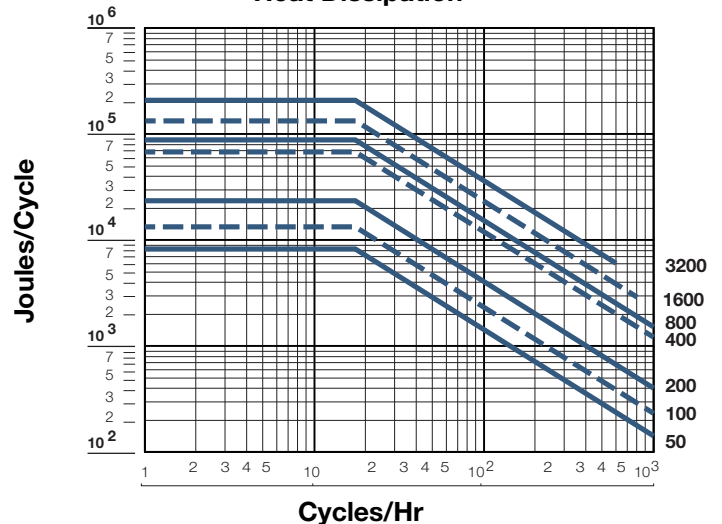

Electro-Magnetic Single Disc Clutch

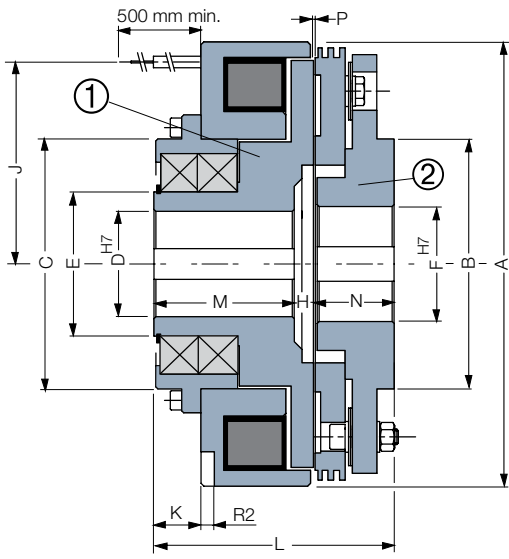

Size 50 - 200

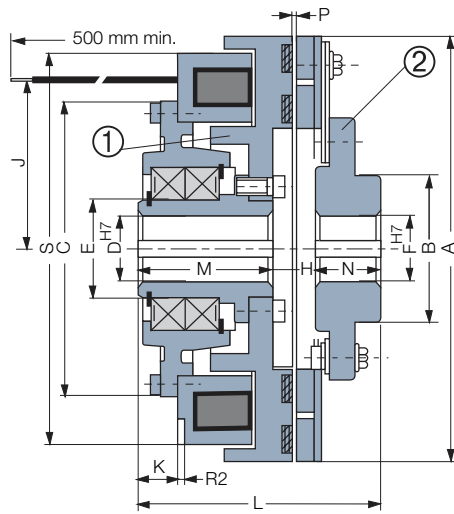

Size 400-3200

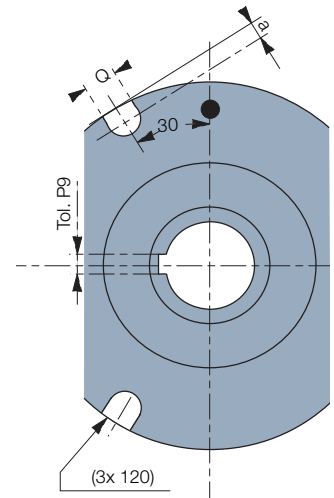

Sizes		50	100	200	400	800	1600	3200
Nom. Torque	[Nm]	50	100	200	400	800	1600	3200
Max. Speed	[min.]	4150	3200	2600	2000	1700	1500	1500
Voltage	[VDC]	24	24	24	24	24	24	103,5
Power	P20 [W]	52	60	81	37	47	94	187
	A	139	173	231	260	300	360	450
	B	85	100	130	100	120	140	175
	C	90	110	155	185	220	265	318
	D* min	22	25	30	35	40	50	65
	D* max	35	45	55	65	75	90	100
	E	50	65	75	80	90	110	130
	F min	22	25	30	35	40	50	65
	F max	40	50	60	70	80	100	110
	H	10	10	12	14	16	20	20
	J	18	23	105	116	133	160	197
	K	17,5	19	24,5	21	24	28	77
	L	95	110	125	135	155	180	280
	M	55	65	73	75	85	100	160
	N	30	35	40	46	54	60	100
	P	0,3	0,3	0,5	0,5	0,6	0,8	0,8
	Q	12	12	16	16	18	20	20
	R2	6	6	7	7	8	10	12
	a	-	-	10	10	10	12	15
	S	-	-	-	249	287	340	426
Inertia	① [kgm²]	0,00270	0,0085	0,0234	0,0635	0,124	0,313	0,781
Inertia	② [kgm²]	0,00335	0,0128	0,0370	0,0342	0,0736	0,2042	0,681
Weight	[kg]	5,7	10,4	20	20,8	34,5	59	130
Connection		Cable						

Direct Drive

Connector Options

(Delivered without cable)

2 poles, capacity : 0,5/2,5mm²

Keyways according to

ISO R773 / BS 4235 / DIN 6885-1 / NF E 22-175, tolerance P9

* Mandatory delivered with finished bore

