

PBM VAR 00

Electro-Magnetic Single Disc Brake

Characteristics

- Electrically operated 12, 24, 103,5 VDC
- Single friction face
- Activated by power on

Utilisation

- Braking or maintaining a pulley or a hub

Particularities

- No backlash
- For dry use
- No residual torque in disengaged position

Adjustments

- Airgap "P" should be adjusted at installation
- Requires wear compensation

Maintenance Manual

- SM 304

Mounting Precautions

- Centre the inductor
- Device intended for horizontal or vertical use

Power Supply

- For 24 volts versions only :
CBC 400-24, CBC 450-24
CBC 500-24, CBC 550-24
CBC 700 (overexcitation)
CBC 140-5 + CBC 140-T (24V)
CBC 140-5 (103,5V)

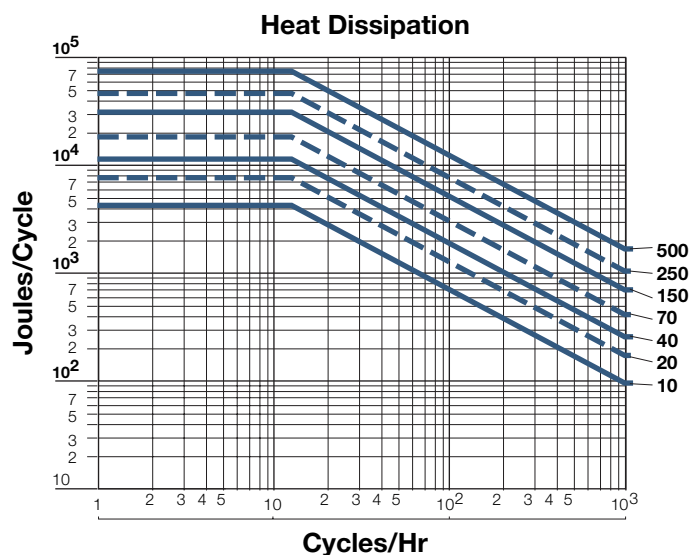

Electro-Magnetic Single Disc Brake

**EUROstandard
Indirect Drive**

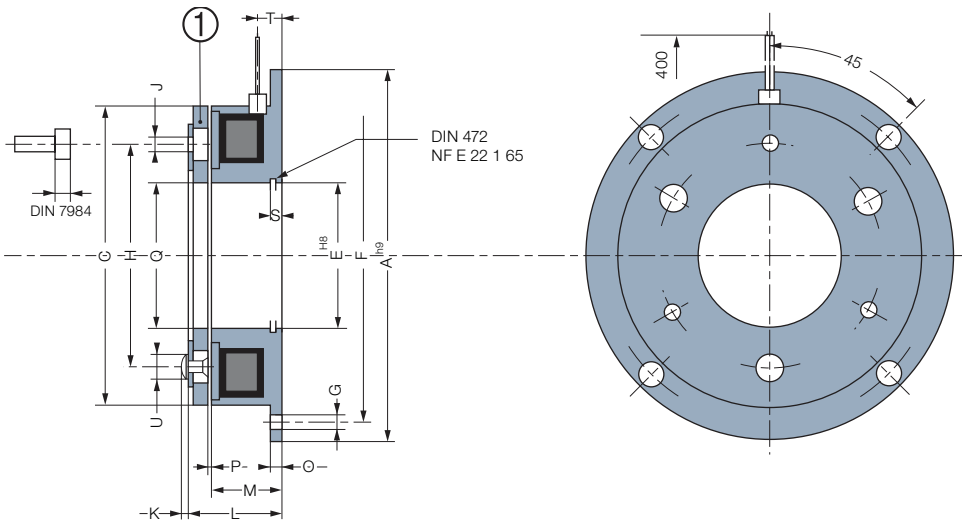

Sizes		10	20	40	70	150	250	500
Nom. Torque	[Nm]	7	15	30	60	120	250	500
Max. Speed	[min.⁻¹]	8000	6000	5000	4000	3000	2500	2000
Power	P20 [12/24/103,5V] [W]	9	16,5	21	24	30	43	58
	A	80	100	125	150	190	230	290
	C	63	81	100	125	160	200	250
	E	35	41	52	62	80	100	125
	F	72	90	112	137	175	215	270
	G For Screw	4xM4	4xM5	4xM6	4xM6	4xM8	4xM8	4xM10
	H	46	60	76	95	120	158	210
	J For Screw	3xM3	3xM4	3xM5	3xM6	3xM8	3xM10	4xM12
	K	1	1,5	2	2,5	3	3	5
	L	22	24,5	28	31	35	41,5	48,3
	M	18	20	22	24	26	30	35
	O	2	2,5	3	3,5	4	5	6
	P	0,2	0,2	0,3	0,3	0,3	0,5	0,5
	Q	35	42	52	62	80	100	125
	S	3,5	4,3	5	5,5	6	7	8
	T	6	6,5	9	9,5	10,5	12	12
	U	6	6	10	12	12	17	20
Inertia	[kgm²]	0,00004	0,00012	0,0005	0,0013	0,0049	0,0140	0,0360
Weight	[kg]	0,3	0,5	0,95	1,7	3,3	5,9	11,5
Connection		Leads			Cable			

Connector Options

(Delivered without cable)

2 poles, capacity : 0,5/2,5mm²

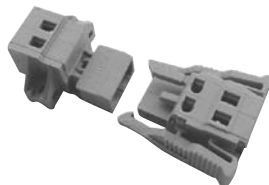

(1)- Fixing "J" on mobile armature by mean of screws DIN 7984 (not provided)