

PBM VAR 01

Electro-Magnetic Single Disc Brake

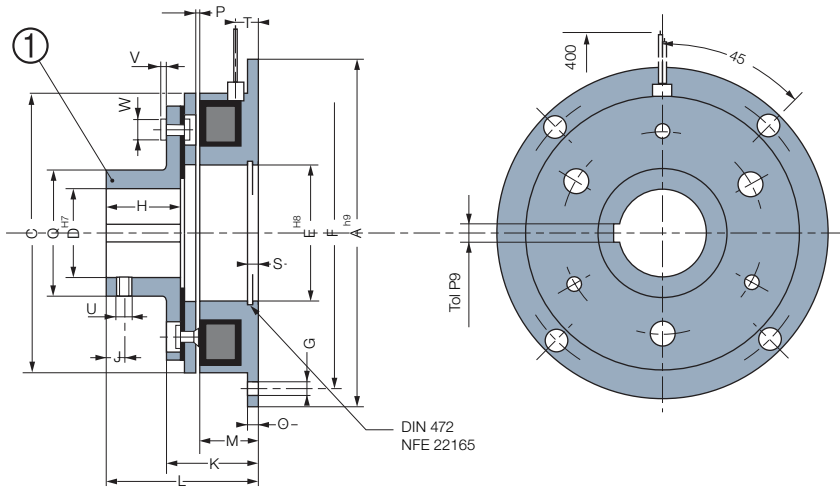

**EUROstandard
Direct Drive**

Sizes		10	20	40	70	150	250	500	
Nom. Torque	[Nm]	7	15	30	60	120	250	500	
Max. Speed	[min.]	8,000	6,000	5000	4000	3000	2500	2000	
Power	P20 [12/24/103,5V]	[W]	9	16,5	21	24	30	43	58
	A		80	100	125	150	190	230	290
	C		63	81	100	125	160	200	250
	D min		10H8	10H8	14H8	14H7	20H7	25H7	25H7
	D std		10/15/17	10/17/20	20/25/30	25/30/35	30/40/45	40/50/60	50/60/80
	D max		17H8	20H8	30H8	35H7	45H7	60H7	80H7
	E		35	42	52	62	80	100	125
	F		72	90	112	137	175	215	270
	G For Screw		4xM4	4xM5	4xM6	4xM6	4xM8	4xM8	4xM10
	H		15	20	25	30	38	48	55
	J		5	6	6	10	10	15	20
	K		25,5	28,5	33	37	42	52,3	62,3
	L		37	44,5	53	61	73	89,5	103,5
	M		18	20	22	24	26	30	35
	O		2	2,5	3	3,5	4	5	6
	P		0,2	0,2	0,3	0,3	0,3	0,5	0,5
	Q		27	32	42	49	65	83	105
	S		3,5	4,3	5	5,5	6	7	8
	T		6	6,5	9	9,5	10,5	12	12
	U		M4	M4	M4	M6	M8	M10	M10
	V		1,5	2	2,5	3	4	1,5	2,5
	W		6	8	10	12	16	20	24
Inertia	① [kgm ²]		0,00006	0,00021	0,00079	0,0020	0,0077	0,0242	0,0705
Weight	[kg]		0,4	0,7	1,32	2,32	4,8	9	17,6
Connection			Leads			Cable			

Connector Options

(Delivered without cable)

2 poles, capacity : 0,5/2,5mm²

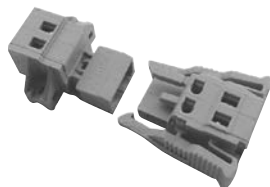

Keyways according to
ISO/R 773 / BS 4235 / DIN 6885-1 / NF E 22-175, tolerance P9

