

# Electrical Data Coil Ratings

EC/EB-375	EC			EB		
Voltage – DC	90	24	6	90	24	6
Resistance @ 20° C – Ohms	453.5	29.3	2.10	446.8	29.3	1.96
Current – Amperes	.198	.82	2.85	.201	.82	3.07
Watts	17	20	17	18	20	18
Coil Build-up – milliseconds	62	60	59	50	60	52
Coil Decay – milliseconds	13	14	15	8	14	10

EC/EB-1000	EC			EB		
Voltage – DC	90	24	6	90	24	6
Resistance @ 20° C – Ohms	248.7	19.7	1.23	248.7	19.7	1.23
Current – Amperes	.36	1.22	4.87	.36	1.22	4.87
Watts	33	29	29	33	29	29
Coil Build-up – milliseconds	250	235	220	235	220	205
Coil Decay – milliseconds	70	75	80	70	75	80

EC/EB-475	EC			EB		
Voltage – DC	90	24	6	90	24	6
Resistance @ 20° C – Ohms	368.9	37.8	2.32	443.1	28.8	2.05
Current – Amperes	.244	.64	2.58	.203	.88	2.93
Watts	22	15	16	18	21	18
Coil Build-up – milliseconds	92	91	90	80	75	70
Coil Decay – milliseconds	18	17	16	8	9	9

EC/EB-1225	EC			EB		
Voltage – DC	90	24	6	90	24	6
Resistance @ 20° C – Ohms	207.3	15.1	1.04	261.7	22.3	1.33
Current – Amperes	.43	1.59	5.79	.34	1.08	4.5
Watts	39	38	35	31	26	27
Coil Build-up – milliseconds	500	490	480	460	445	435
Coil Decay – milliseconds	220	230	240	190	160	140

EC/EB-650	EC			EB		
Voltage – DC	90	24	6	90	24	6
Resistance @ 20° C – Ohms	225	17.7	1.16	257.2	18.3	1.24
Current – Amperes	.4	1.36	5.19	.35	1.3	4.84
Watts	36	33	31	32	31	29
Coil Build-up – milliseconds	120	115	110	112	108	105
Coil Decay – milliseconds	20	20	20	12	13	14

ATC, ATTC, ATB, ATTB-25	ATC			ATB		
Voltage – DC	6	24	90	6	24	90
Resistance @ 20° C – Ohms	1.37	20.2	290	1.37	20.2	290
Current – Amperes	4.38	1.19	.31	4.38	1.19	.31
Watts	26.3	28.6	27.9	26.3	28.6	27.9
Coil Build-up – milliseconds	145	145	145	145	145	145
Coil Decay – milliseconds	8	8	8	9	9	9

FB/ER-375, 475, 650	FB-375		FB-475		FB-650	
Voltage – DC	90	24	90	24	90	24
Resistance @ 20° C – Ohms	446	29	310	22	235	16
Current – Amperes	.201	.822	.300	1.09	.380	1.426
Watts	18	19	27	26	34	34
Coil Build-up – milliseconds	40	40	80	80	90	90
Coil Decay – milliseconds	5	10	8	10	10	10

ATC, ATTC, ATB, ATTB-55	ATC			ATB		
Voltage – DC	6	24	90	6	24	90
Resistance @ 20° C – Ohms	1.21	19.6	230	1.21	19.6	230
Current – Amperes	4.96	1.22	.39	4.96	1.22	.39
Watts	29.8	29.3	35.2	29.8	29.3	35.2
Coil Build-up – milliseconds	200	200	200	210	210	210
Coil Decay – milliseconds	20	20	20	35	35	35

ER-825, 1225	ER-825		ER-1225	
Voltage – DC	90	24	35-75	
Resistance @ 20° C – Ohms	305	21.5	235	
Current – Amperes	.29	1.1	.383	
Watts	26	27	35	
Coil Build-up – milliseconds	400	–	700	
Coil Decay – milliseconds	20	–	20	

ATC, ATTC, ATB, ATTB-115	ATC			ATB		
Voltage – DC	6	24	90	6	24	90
Resistance @ 20° C – Ohms	1.02	16.5	182	1.02	16.5	182
Current – Amperes	5.91	1.46	.50	5.91	1.46	.50
Watts	35.4	35	44.6	35.4	35	44.6
Coil Build-up – milliseconds	145	145	145	150	150	150
Coil Decay – milliseconds	40	40	40	45	45	45

EC/EB-825	EC			EB		
Voltage – DC	90	24	6	90	24	6
Resistance @ 20° C – Ohms	221	20.9	1.098	223.3	20.4	1.27
Current – Amperes	.407	1.15	5.464	.4	1.18	4.74
Watts	37	28	33	36	28	28
Coil Build-up – milliseconds	225	200	180	170	170	170
Coil Decay – milliseconds	130	122	115	80	75	70

# Electrical Data Coil Ratings

UM/EM/UMFB/EMFB	Clutch	UM/EM Brake	Clutch	UM/EM Brake	Clutch	UM/EM Brake	UMFB/EMFB Brake	UMFB/EMFB Brake	
Voltage – DC	90	90	24	24	6	6	24	90	
Resistance (ohms)	EM-50	452	429	31.8	28.8	1.9	1.9	28.8	429
	EM-100	392	392	26.7	26.7	1.8	1.8	21.7	308
	EM-180	392	392	26.7	26.7	1.8	1.8	21.7	308
	EM-210/215	248	248	17.9	17.9	1.22	1.22	13.3	205
Amperes	EM-50	.20	.21	.76	.83	3.2	3.2	.83	.21
	EM-100	.23	.23	.90	.90	3.3	3.3	1.1	.29
	EM-180	.23	.23	.90	.90	3.3	3.3	1.1	.29
	EM-210/215	.36	.36	1.3	1.3	4.9	4.9	1.8	.38
Watts	EM-50	18	19	19	20	20	20	20	19
	EM-100	21	21	22	22	20	20	27	27
	EM-180	21	21	22	22	20	20	27	27
	EM-210/215	33	33	32	32	30	30	43	34
Build-up (millisecond)	EM-50	52	53	52	53	52	53	40	40
	EM-100	72	75	72	75	72	70	80	80
	EM-180	72	75	72	75	72	70	80	80
	EM-210/215	120	100	120	100	110	100	90	90
Decay (millisecond)	EM-50	6	5	6	5	6	5	5	5
	EM-100	12	10	12	10	12	10	8	8
	EM-180	12	10	12	10	12	10	8	8
	EM-210/215	20	10	20	10	20	10	10	10

# Electrical Data Coil Ratings

Unit Size	SF/PB 120			SF/PB 170			SF/PB 250		
Voltage – DC	6	24	90	6	24	90	6	24	90
Resistance @ 20°C – Ohms	6.32	104	1386	6.96	111.2	1506	5	76.4	1079
Current – Amperes	.949	.230	.065	.861	.215	.060	1.2	.314	.084
Watts	5.69	5.52	5.85	5.85	5.16	5.37	7.2	7.5	7.51
Coil Build-up – milliseconds	12	12	11	17	17	16	48	48	44
Coil Decay – milliseconds	8	8	7	8	7	6	15	15	13

Unit Size	SF/PB 400			SF-500			PB & PC 500			SF-650		
Voltage – DC	6	24	90	6	24	90	6	24	90	6	24	90
Resistance @ 20°C – Ohms	4.88	73	1087	1.076	14.9	206.1	1.36	23.8	251.1	1.16	17.7	225
Current – Amperes	1.23	.322	.083	5.58	1.61	.44	4.4	1.01	.36	5.19	1.36	.4
Watts	7.39	7.96	7.45	34	39	39	26	24	32	31	33	36
Coil Build-up – milliseconds	154	154	154	82	85	90	84	87	93	110	115	120
Coil Decay – milliseconds	62	60	55	40	40	40	38	35	30	50	50	50

Unit Size	PB-650			SF-825			SF-825 Brg			PB & PC 825			SF-1000			PB & PC 1000		
Voltage – DC	6	24	90	6	24	90	6	24	90	6	24	90	6	24	90	6	24	90
Resistance @ 20°C – Ohms	1.24	18.3	257.2	1.23	20.9	267.0	1.098	14.6	221	1.27	20.4	223.3	1.07	14.4	214.4	1.23	19.7	248.7
Current – Amperes	4.84	1.31	.35	4.9	1.15	.34	5.464	1.65	.407	4.74	1.18	.4	5.61	1.67	.42	4.87	1.22	.36
Watts	29	31	32	29	28	30	33	40	37	28	28	36	34	40	38	29	29	33
Coil Build-up – milliseconds	100	105	110	222	200	245	180	200	225	170	170	170	256	275	283	205	220	235
Coil Decay – milliseconds	50	50	50	105	120	100	115	120	130	70	75	80	123	105	90	70	75	80

Unit Size	SF-1225			PB & PC 1225			SF-1525			PB & PC 1525			SF-1525 H.T.		
Voltage – DC	6	24	90	6	24	90	6	24	90	6	24	90	6	24	90
Resistance @ 20°C – Ohms	1.21	19.5	268.3	1.33	22.3	261.7	1.11	15.5	239.1	1.45	19.8	258.4	.55	7.63	113.4
Current – Amperes	4.97	1.23	.34	4.5	1.08	.34	5.41	1.55	.38	4.13	1.21	.35	10.83	3.14	.794
Watts	30	30	30	27	26	31	32	37	34	25	29	31	65	75	72
Coil Build-up – milliseconds	475	490	510	300	320	350	505	535	575	470	490	512	480		560
Coil Decay – milliseconds	240	230	220	190	190	190	230	237	215	200	170	140	210		160

NOTES: Build-up time equals current to approximately 90% of steady state value and flux to 90%. Decay time equals current to approximately 10% of steady state value and flux to 10%. Approximately because current leads or lags flux by a small amount.

# Electrical Data Installation Procedure

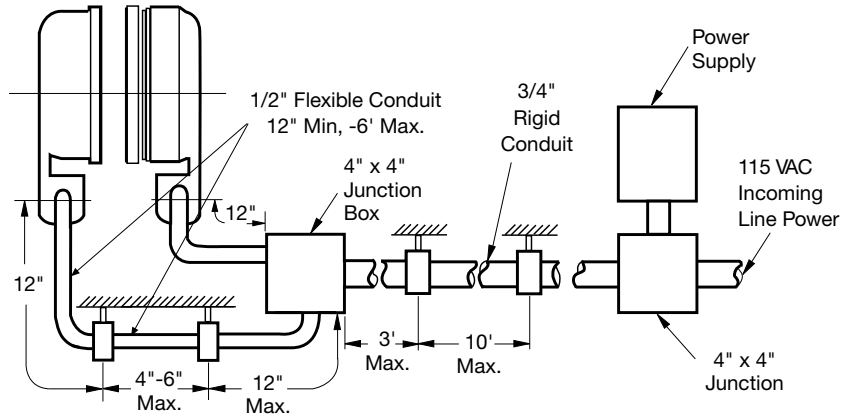

## Recommended Electrical Installation Procedure for Warner Electric Clutches and Brakes

Warner Electric clutches and brakes conform to UL (Underwriters Laboratories) requirements. All packaged products come with conduit boxes or are enclosed in housings with provision for electrical conduit connection. All sizes 400 and larger SF clutch fields and brake magnets accept UL conforming conduit boxes available from Warner Electric.

The National Electrical Code (NEC) requires that conductors subject to physical damage be adequately protected. When electrical conduit is used, a minimum of 12" of 1/2" flexible conduit is to be used between each brake and/or clutch and its box. This construction will prevent improper bearing loading in bearing mounted units and ease field and magnet assembly and disassembly.

Refer to the information below for proper installation practices and wire sizes.

Notwithstanding the above recommendations, all electrical installations should conform to NEC and/or other governing electrical codes.

## Recommended wire size versus maximum distance

Wire Size AWG	Fractional Horsepower Sizes 170-400			Integral Horsepower Sizes 500-1525		
	Distance (feet)			Distance (feet)		
	6 Volt	24 Volt	90 Volt	6 Volt	24 Volt	90 Volt
18	20	280	1000	4	65	700
16	30	430		6	95	
14	50	720		10	160	
12	75	720		10	160	
10	125			25	400	
8	200			40		

General construction wire type MTW or THW recommended.  
 #6 terminal screws (size 400 and smaller) are to be torqued to 15 in.lb.  
 #8 terminal screws (size 500 and larger) are to be torqued to 20 in.lb.

# Electrical Data Coil Suppression & Clutch/Brake Overlap

Users of electric clutch and brake systems are sometimes concerned that a clutch and brake will oppose each other or “overlap” during switching, i.e., when the clutch is switched off and the brake is switched on, or vice versa. This concern relates primarily to dual armature type clutch/brakes similar to the Warner Electric Electro Module product line, as compared to shuttle armature clutch/brakes.

In use, Warner Electric clutches and brakes are not subject to overlap when Zener diode coil suppression techniques are applied to the clutch/brake control. All Warner Electric clutch/brake controls use Zener diode suppression to eliminate any overlap situations.

The charts below graphically display current decay of the clutch and current rise of the brake with Zener diode and with straight diode suppression. In Chart 1, which shows brake and clutch operation with Zener diode suppression, the “Overlap Area” below the intersection of the brake and clutch current lines shows potential for the devices to fight one another. But this

intersection occurs at an extremely low current level and the armature Autogap® springs keep the friction surfaces of the brake armature and magnet separate at such low currents. Even though there is the appearance of a minor clutch/brake overlap in this instance, the brake armature has not yet contacted the brake magnet. Chart 2 shows a much larger overlap area since straight diode suppression is used in this circuit. Clutch current has not decayed fully as the brake is engaged and the load is brought to zero speed.

Clutch and brake coils are inductors. Inductance is the electrical equivalent to mechanical inertia and an energized coil dissipates its energy when turned “off.” Upon removal of power, voltage across an inductor reverses and current continues to flow in the same direction until the energy is fully dissipated. Without suppression in the control circuit, an arc can result from this potentially very large reverse voltage which can damage the electrical switching contacts.

Consequently, Zener diode suppression circuitry, by limiting the reverse voltage to

a sufficiently high but safe level, has two major benefits:

- Hastens coil decay
- Protects the switching contacts

The schematics below show circuits with no suppression and both straight diode and Zener diode suppression.

The rapid coil decay of Zener diode suppression lets users enjoy the major advantages which dual armatures have over single, “shuttle” armatures. These include:

- Better heat dissipation – greater area to give off heat and more “off” time.
- Longer life – two armatures absorb wear.
- Armature Autogap® self adjusting for the life of the unit
- Enhanced repeatability and controllability with the use of a light preload spring to keep the armatures in light contact with their mating surfaces, eliminating armature movement time and reducing noise and spline wear. Warner Electric utilizes this preload spring in some packaged clutch/brake models including ceramic EPs and Unimodules and Smooth Start Unimodules.

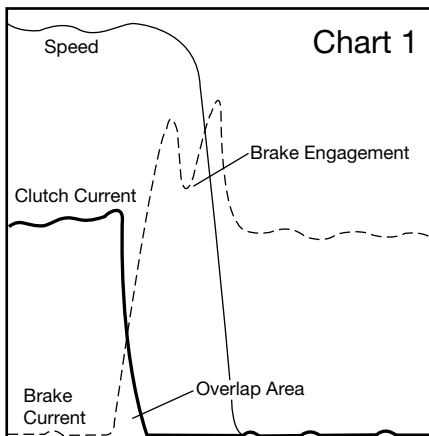

## Brake Engagement with Zener Diode Suppression

Clutch current decay and brake current rise overlap, but the brake armature is not engaged until well past the overlap point. Note that the “blip” in the brake current trace coincides with the sharp decline in the “speed” trace, indicating brake armature engagement at that point.

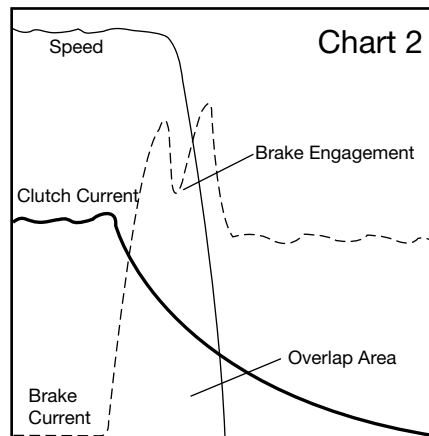

## Brake Engagement with Straight Diode Suppression

Clutch current decay is much slower than with Zener diode suppression as shown in Chart 1, greatly increasing the overlap area. The current level in the clutch coil is much higher at the point of brake engagement than with Zener diode suppression.

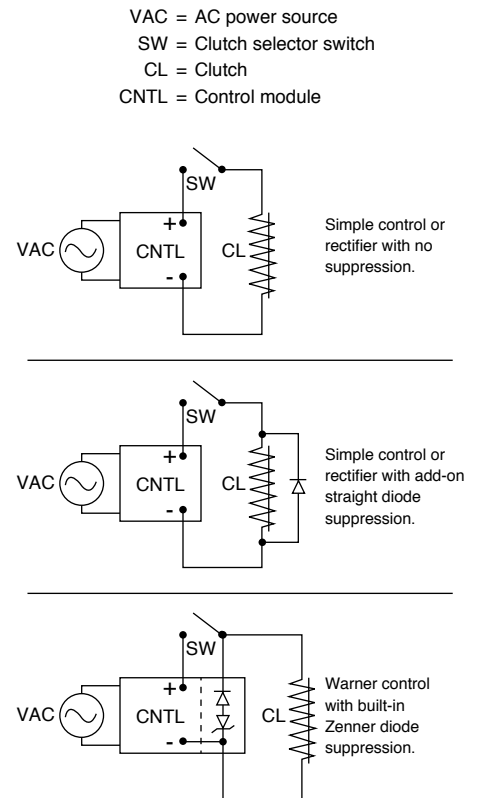

Overexcitation is a technique which makes a clutch or brake engage faster and have greatly improved starting and stopping accuracy. It involves applying over voltage to the clutch or brake coil to reduce current build up time, thereby reducing the magnetizing time.

The graphs below show current rise and shaft speed for an identical system using a Warner Electric EP-400 clutch/brake both with and without overexcitation. The effect of overexcitation is to reduce the time needed to achieve full current and thereby reduce the time required to achieve full speed with a clutch or zero speed with a brake. In the example below, "time to start" is approximate-

ly 70 ms without overexcitation. This is reduced to 30 ms when overexcitation is applied. This time is comparable to the coil buildup times stated on page G-10. The "time to stop" has been similarly reduced; the nominally excited system requires about 110 ms to stop the load, while this is accomplished in only 50 ms with overexcitation.

Overexcitation does not increase torque. Rather, the reduction in start-stop times comes from reduced coil current build up times (or "time to current"). For many common industrial applications, the reduction in "time to speed" and "time to stop" is one half when using overexcitation.

The use of overexcitation on a clutch/brake system does not increase system wear. In fact, the clutch/brake wear rate may be reduced because slippage and energy dissipation is marginally reduced in the clutch/brake. Compliance in the drivetrain may absorb some of the start/stop inertia or wear may be observed in other drivetrain components. Whenever overexcitation is used, adequate coil suppression must be employed. Please refer to "Coil Suppression and Clutch/Brake Overlap" on page G-12.

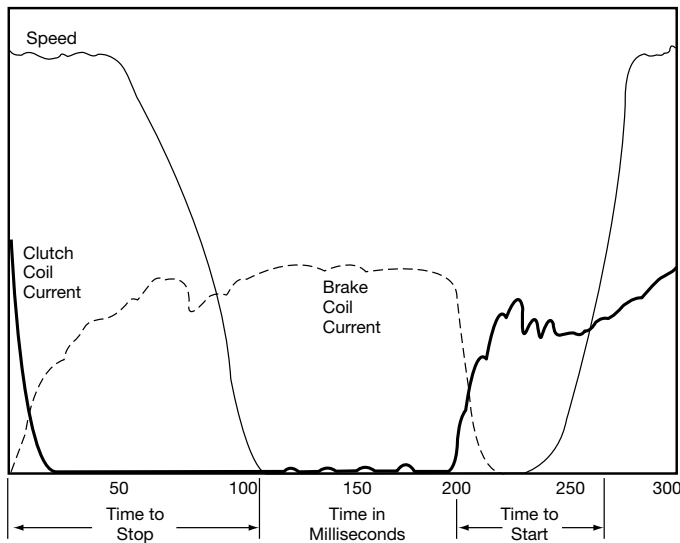

**Chart 1**

## Without Overexcitation

Current/speed trace of EP400 clutch/brake being run through a single stop/start cycle. Note that 110 milliseconds is required to stop from the time the clutch coil is de-energized and the brake coil is energized. At the 200 milliseconds point on the graph the clutch coil is energized and the load is at speed 70 milliseconds later. Note that the coil current is still increasing after the load is at full speed.

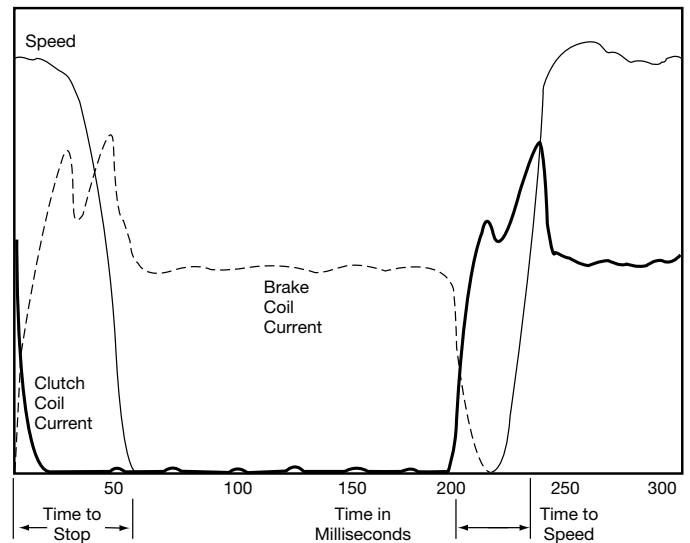

**Chart 2**

## With Overexcitation

Current/speed trace of EP400 clutch/brake being run through a single stop/start cycle. With overexcitation, both brake and clutch coil currents build much faster with concurrent reductions in both stop and start times, when compared with Chart 1.

