

EUM-W Series Enclosed UniModule

EUM-W Series Clutch/Brakes and Clutch Combinations

Contamination-Proof Design

The washdown version of the EUM uses stainless steel shafting, USDA approved coating, corrosion resistant fasteners and special sealing accessories for use in washdown applications.

EUM-W (white) units are ideal for applications that require frequent washing with high pressure spray systems. Their smooth exterior does not allow food particles, or other contaminants, to get trapped and become host to bacteriological growth.

- USDA approved coating
- Stainless steel shafting
- Sealing (gaskets and plugs)
- Smooth exterior – easy washdown
- Corrosion resistant hardware
- Sealed/shielded bearings
- Baffled ventilation system
- Designed for IP65 enclosure requirements
- UL listed when conduit box is employed

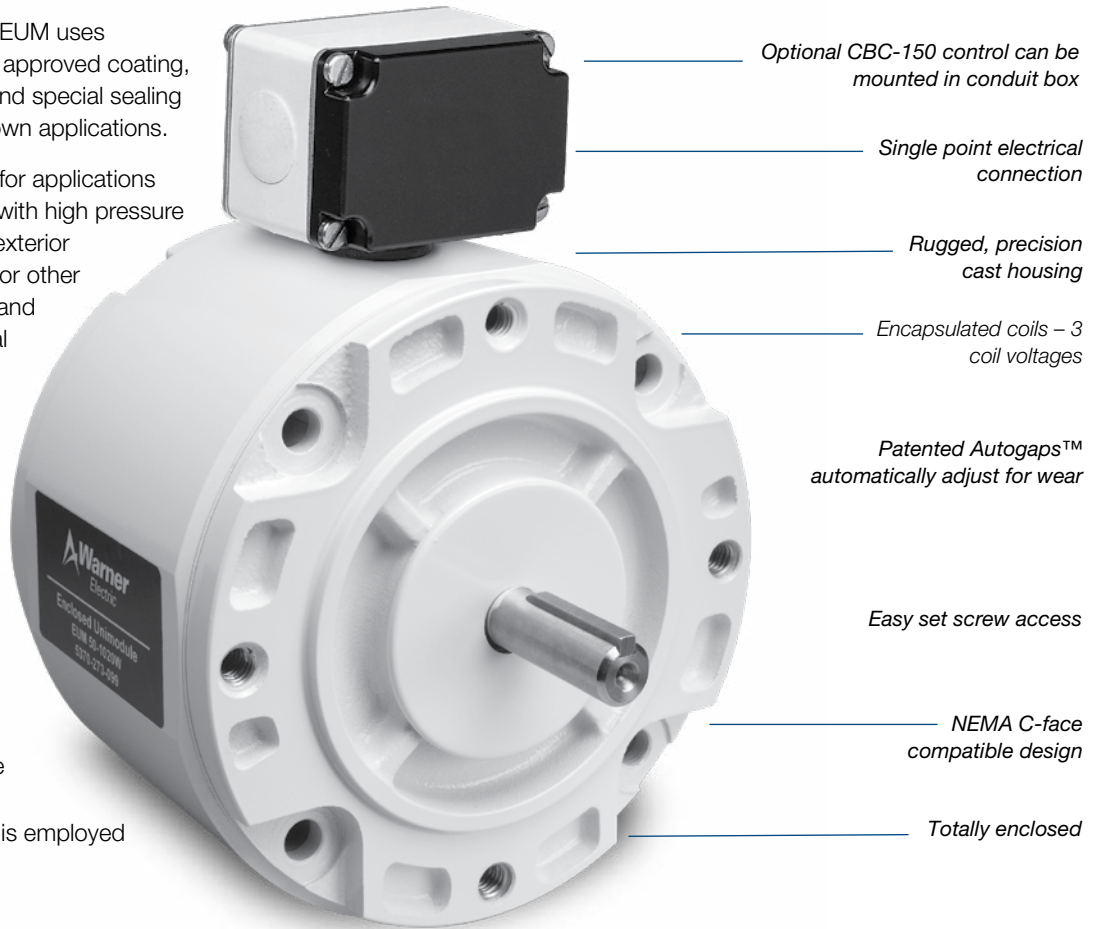

One piece, C-face package completely assembled and factory aligned. Mates easily with standard motors and reducers. Foot mounted package also available. Easy-to-install and no maintenance required.

Bolt-it-down, wire-it-up. UniModule is ready to go. Automatic adjustment for wear. Complete control capability.

Available with built-in power supply or used with separate controls for soft starts and stops ... or for fast acting, accurate cycling.

- Factory burnished for out-of-box torque
- Superior heat transfer
- Dual endbell for easy repair
- Single point electrical connection
- Optional conduit box
- Optional integral control

Improved Hub Design/Autogap System

- Improved for longer spline life
- Autogap functions over broad current range
- New hub material

EUM-W Washdown Unit

EUM-W (white) units are ideal for applications that require frequent washing with high pressure spray systems.

EUM-W - Selection Procedure

Warner Electric EUM-W clutch/brake modules normally mount in either of two methods: NEMA C-face mounting or base mounting.

1. Select Configuration

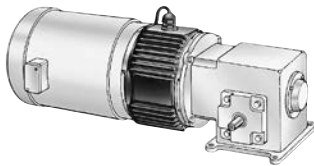

a. NEMA C-face Mounting (1020 and 1040 Configurations)

Based on the NEMA C-face frame size of the prime mover, select the corresponding clutch/brake package size from the Frame Size Selection chart. Size 100 houses the components of the size 180 in a size 50 frame, while size 215 incorporates size 210 components.

Select either a 1020 or a 1040 (EUM-W only) configuration. The 1020 is a clutch/brake, while the 1040 is a clutch only. The 2030 configuration is a clutch/brake for base mounting.

Frame Size Selection

NEMA Frame Size	EUM-W Size
56C/48Y	EUM50-W* EUM100-W**
182C/143TC 184C/145TC	EUM180-W
213C/182TC 215C/184TC	EUM210-W
213TC/215TC	EUM215-W

* For 56C/48Y Frame motors 3/4 HP and smaller the EUM100-W size may be used where extended life is desirable.

** EUM100-W size is recommended for motors 1 HP and larger.

b. Base Mounting (2030 Configuration)



Washdown enclosed UniModule assemblies may be mounted as separate drive units driven from the prime mover by V-belts, chain and sprockets, couplings, timing belts and other standard power transmission components.

Select the correct size 2030 package from the Horsepower vs. Shaft Speed chart by determining the motor horsepower and RPM at the module location. The correct size EUM-W is shown at the intersection of the HP and operating speed. For additional sizing information, refer to the technical sizing procedure (step 2).

2. Determine Technical Requirements

Technical considerations for sizing and selection are torque and heat dissipation. Each merits careful consideration, especially heat dissipation as over time, use in excessive temperature environments will have an adverse effect on bearing life and coil wire insulation integrity.

Compare the calculated torque requirement with the average dynamic torque ratings. Select a unit with adequate torque. If the unit selected on torque is different than the unit selected based on heat, select the larger size unit.

Two heat dissipation curves are shown. A fan kit accessory is available for use with these units.

Horsepower vs. Shaft Speed

HP	SHAFT SPEED AT CLUTCH (IN RPM)																	
	100	200	300	400	500	600	700	800	900	1000	1100	1200	1500	1800	2000	2400	3000	3600
1/4	Shaded	Shaded	Shaded	Shaded	Shaded	Shaded	Shaded	Shaded	Shaded	Shaded	Shaded	Shaded	Shaded	Shaded	Shaded	Shaded	Shaded	Shaded
1/2	Shaded	Shaded	Shaded	Shaded	Shaded	Shaded	Shaded	Shaded	Shaded	Shaded	Shaded	Shaded	Shaded	Shaded	Shaded	Shaded	Shaded	Shaded
3/4	Shaded	Shaded	Shaded	Shaded	Shaded	Shaded	Shaded	Shaded	Shaded	Shaded	Shaded	Shaded	Shaded	Shaded	Shaded	Shaded	Shaded	Shaded
1	Shaded	Shaded	Shaded	Shaded	Shaded	Shaded	Shaded	Shaded	Shaded	Shaded	Shaded	Shaded	Shaded	Shaded	Shaded	Shaded	Shaded	Shaded
1-1/2	Shaded	Shaded	Shaded	Shaded	Shaded	Shaded	Shaded	Shaded	Shaded	Shaded	Shaded	Shaded	Shaded	Shaded	Shaded	Shaded	Shaded	Shaded
2	Shaded	Shaded	Shaded	Shaded	Shaded	Shaded	Shaded	Shaded	Shaded	Shaded	Shaded	Shaded	Shaded	Shaded	Shaded	Shaded	Shaded	Shaded
3	Shaded	Shaded	Shaded	Shaded	Shaded	Shaded	Shaded	Shaded	Shaded	Shaded	Shaded	Shaded	Shaded	Shaded	Shaded	Shaded	Shaded	Shaded
5	Shaded	Shaded	Shaded	Shaded	Shaded	Shaded	Shaded	Shaded	Shaded	Shaded	Shaded	Shaded	Shaded	Shaded	Shaded	Shaded	Shaded	Shaded
7-1/2	Shaded	Shaded	Shaded	Shaded	Shaded	Shaded	Shaded	Shaded	Shaded	Shaded	Shaded	Shaded	Shaded	Shaded	Shaded	Shaded	Shaded	Shaded
10	Shaded	Shaded	Shaded	Shaded	Shaded	Shaded	Shaded	Shaded	Shaded	Shaded	Shaded	Shaded	Shaded	Shaded	Shaded	Shaded	Shaded	Shaded

*For applications with speeds below 100RPM, please contact Warner Electric Application Support.

EUM-W Series Enclosed UniModule

a. Heat Dissipation Sizing

Friction surfaces slip during the initial period of engagement and, as a result, heat is generated. The clutch/brake selected must have a heat dissipation rating greater than the heat generated by the application. Therefore, in high inertia or high cycle rate applications, it is necessary to check the heat dissipation carefully. Inertia, speed and cycle rate are the required parameters.

Heat dissipation requirement is calculated as follows:

$$E = 1.7 \times WR^2 \times (N/100)^2 \times F$$

where:

$$E = \text{Heat (lb. ft./min.)}$$

WR^2 = Total reflected inertia at the clutch/brake shaft. Include the clutch/brake output inertia. (lb.ft.²)

N = Speed in revolutions per minute (RPM)

F = Cycle rate in cycles per minute (CPM)

Compare the calculated heat generated in the application to the unit ratings using the heat dissipation curves. Select the appropriate unit that has adequate heat dissipation ability.

Washdown Enclosed UniModule Heat Dissipation Curves

EUM 50-W

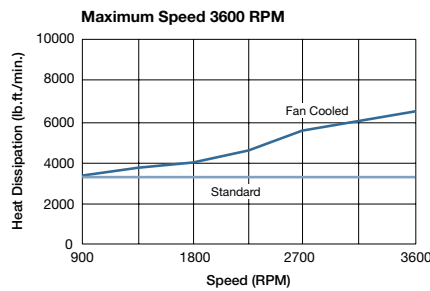

EUM 100/180-W

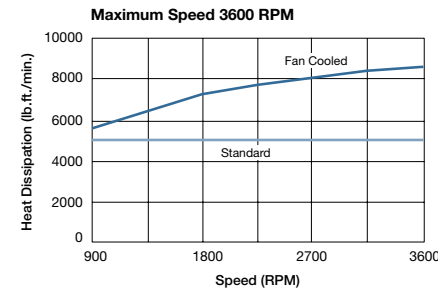

EUM 210/215-W (fan not available for 215)

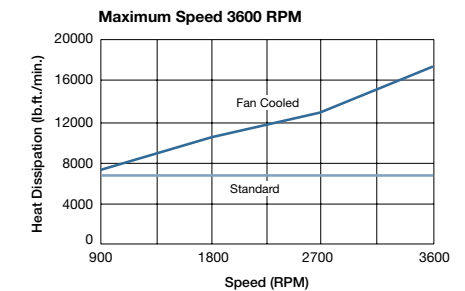

b. Torque Sizing

For most applications, the correct size clutch/brake can be selected from the Horsepower vs. Shaft Speed chart.

Determine the motor horsepower and the RPM at the clutch/brake. The correct size unit is shown at the intersection of horsepower and shaft speed.

If the static torque requirements are known, refer to the Specifications Table to select a unit.

For some applications, the torque requirement is determined by the time allowed to accelerate and decelerate the load. (This time is generally specified in milliseconds.) For these applications, it is necessary to determine the torque requirement based on load inertia and the time allowed for engagement.

The torque requirements are calculated as follows:

$$T = (WR^2 \times N) / (308 \times t)$$

where:

$$T = \text{Average Dynamic Torque (lb. ft.)}$$

WR^2 = Total reflected inertia at the clutch/brake shaft. Include the clutch/brake output inertia. (lb. ft.²)

N = Speed in revolutions per minute (RPM)

t = Time allowed for the engagement (sec)

C-face Clutch/Power-on Brake Dynamic Torque Curves

EUM 50-W

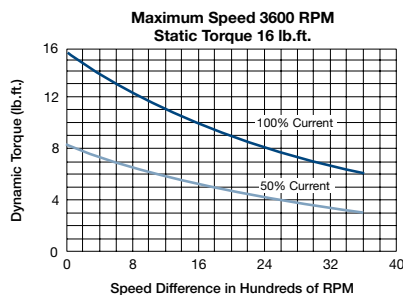

EUM 100/180-W

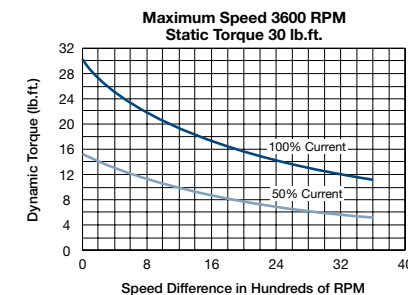

EUM 210/215-W

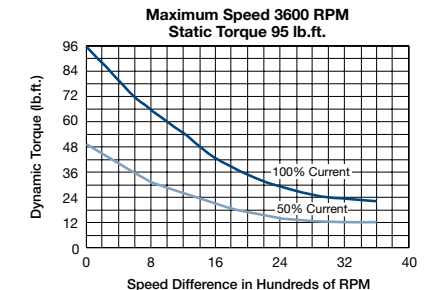

EUM-W Series Enclosed UniModule

Specifications

UniModule Size	Shaft Dia.	Static Torque (lb. ft.)	Horsepower	Max. RPM	Voltage DC	NEMA Frame Size
EUM50-W	.625	16	1/4-3/4	3600	6, 24 and 90	56C/48Y
EUM100-W	.625	30	1-2	3600	6, 24 and 90	56C/48Y
EUM180-W	.875	30	1-2	3600	6, 24 and 90	182C/143TC 184C/145TC
EUM210-W	1.125	95	3-5	3600	6, 24 and 90	213/182TC 215C/184TC
EUM215-W	1.375	95	7-1/2-10	3600	6, 24 and 90	213TC/215TC

3. Select Options

Accessories

Warner Electric Enclosed Washdown UniModules can be fitted with several accessories to extend their capacity and ease of mounting.

Conduit Box

NEMA 4 and UL listed, available in standard and washdown versions.

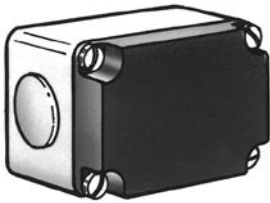

Integral Control

The CBC-150 dual channel control fits into the cover of the conduit box. It is suitable for AC side switching (triac or relay) and includes high performance suppression.



Fan Kit (UM and EUM 1020 only)

Extends the thermal capacity of an EUM-W. Mounts between motor and EUM-W, includes shaft, fan, guard and hardware. Available in standard black coating or food grade approved white coating.



Mounting Brackets

Two styles of mounting brackets are available for simplified installation. The base mount is used with the 2030 configuration. A motor mount is also available and provides sturdy support for a 1020 or 1040 combination with motor.

(Optional)

Motor Mount (M)

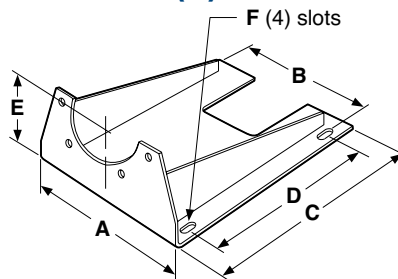

For use with 1020 and 1040 Combinations.

Size	A	B	C	D	E	F	Part No.
50/100/180*	9.25	8.25	10.50	8.000	4.50	.800 x .406	5370-101-080
210/215	11.50	10.50	12.00	9.000	5.25	.750 x .406	5371-101-026

* Because of diameter limitations, EUM-W bases are available in 4.5" center height (143/145TC) only.

Base (B)

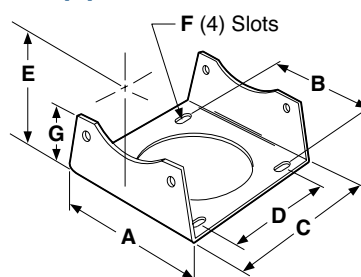

For use with 2030 and 3040 units.

Size	A	B	C	D	E	F	G	Part No.
50/180*	6.625	5.680	5.672	4.000	4.500	.750 x .406	3.000	5370-101-047
210	9.000	7.750	8.260	6.000	5.250	.750 x .531	3.375	5371-101-025

* Because of diameter limitations, EUM-W bases are available in 4.5" center height (143/145TC) only.

EUM-W Series Enclosed UniModule

Selection and Ordering Information

Part Numbers

Model No.	Voltage	Original Part No.
1020 Configuration – Enclosed EUM		
	6	5370-273-100
EUM-50-1020W	24	5370-273-101
	90	5370-273-099
EUM-100-1020W	6	5370-273-108
	24	5370-273-109
EUM-180-1020W	90	5370-273-107
	6	5370-273-116
EUM-210-1020W	24	5370-273-117
	90	5370-273-115
EUM-215-1020W	6	5371-273-056
	24	5371-273-057
EUM-210-1020W	90	5371-273-055
	6	5371-273-086
EUM-215-1020W	24	5371-273-087
	90	5371-273-088
2030 Configuration – Washdown EUM-W		
	6	5370-273-104
EUM-50-2030W	24	5370-273-105
	90	5370-273-103
EUM-180-2030W	6	5370-273-120
	24	5370-273-121
EUM-210-2030W	90	5370-273-119
	6	5371-273-060
EUM-210-2030W	24	5371-273-061
	90	5371-273-059

How to Order

Motor or Reducer Mounted

Simply combine the size number with the configuration of the required UniModule. Specify voltage. See chart for specific part numbers. Order optional conduit box if desired.

Example

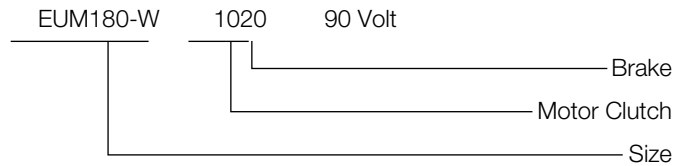

Base Mounted

Simply combine the size number with the configuration of the required UniModule. Specify voltage. See chart for specific part numbers. Order optional conduit box if desired.

Example

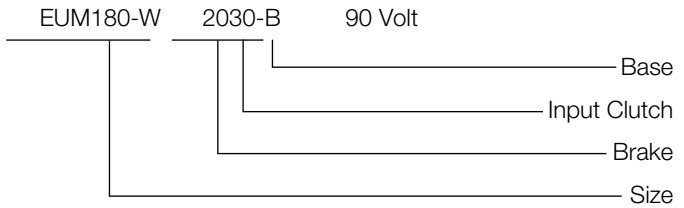

Accessories

Option	Size	Washdown UniModule	
Conduit box	All sizes	5370-101-045	
Control	CBC-150-1	6004-448-001	
	CBC-150-2	6004-448-002	
Base Mount Kits	50/180*	5370-101-047	
	210	5371-101-025	
Motor Mount Kits	50/100/180*	5370-101-080	
	for 1020, 1040	210/215	5371-101-026
Fan Kits	50/100	5370-101-060	
	for 1020	180	5370-101-061
		210	5371-101-033

* Because of diameter limitations, EUM bases are available in 4.5" center height (143/145TC) only.

EUM-W Series Enclosed UniModule

EUM-W-1020 Clutch/Brake Combination

SIZE 50/100/180

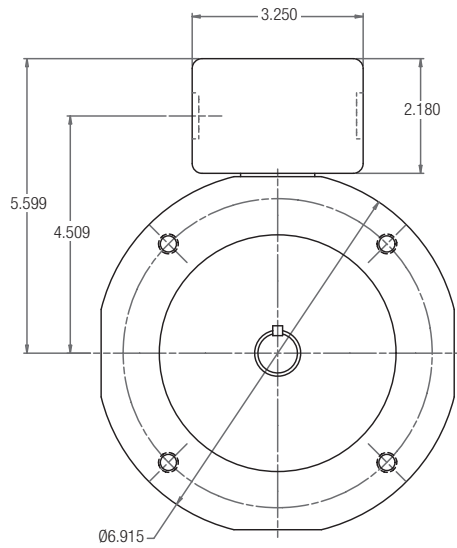
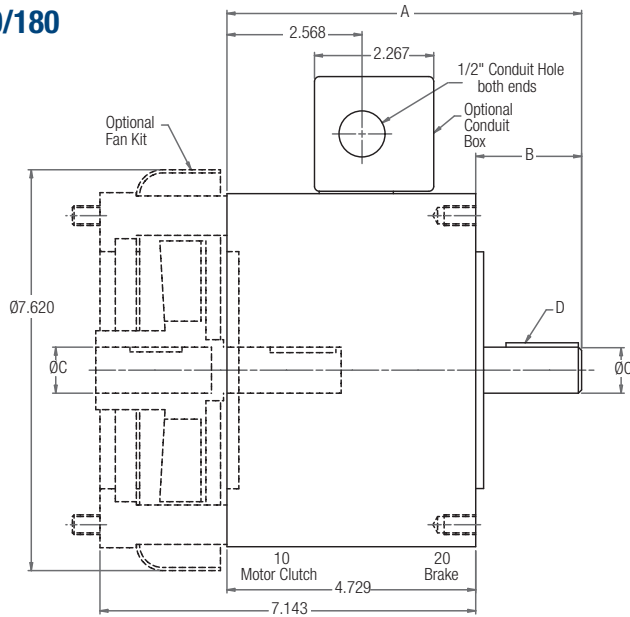

Note: Washdown UniModules (EUM-W) do not have a finned housing.

SIZE 210/215

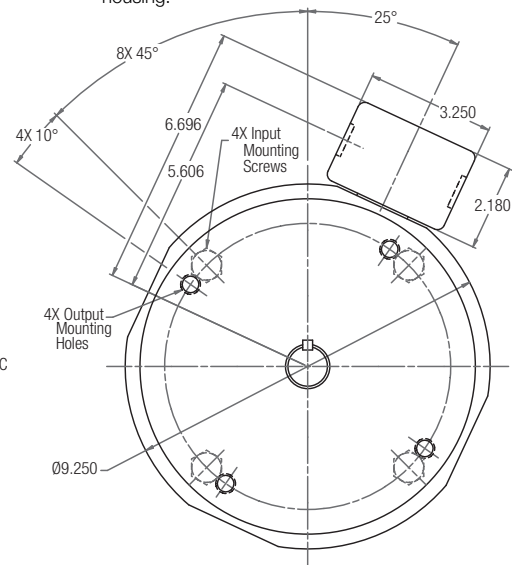
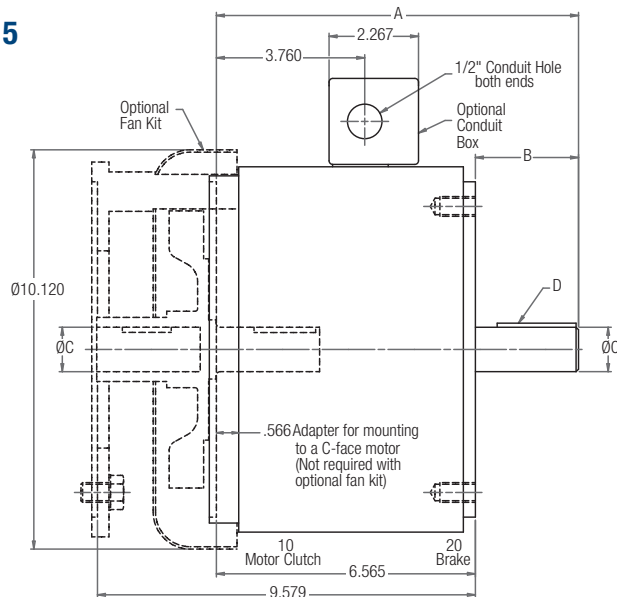

All dimensions are nominal, unless otherwise noted.

Dimensions

Size	A	B	C	D
50	6.742	2.013	0.625	3/16 x 3/16
100	6.757	2.028	0.625	3/16 x 3/16
180	6.757	2.028	0.875	3/16 x 3/16
210	9.179	2.614	1.125	1/4 x 1/4
215	9.679	3.114	1.375	5/16 x 5/16

Specifications

For standard NEMA frame dimensions, see page G-3.

UniModule Size	Shaft Dia.	Horsepower	Static Torque lb. ft.	CPM @1750 RPM	Max. RPM	Voltage DC	NEMA Frame Size
EUM50-W	.625	1/4-3/4	16	125	3600	6, 24 or 90	56C/48Y
EUM100-W	.625	1	30	90	3600	6, 24 or 90	56C/48Y
EUM180-W	.875	1-2	30	90	3600	6, 24 or 90	182C/143TC 184C/145TC
EUM210-W	1.125	3-5	95	37	3600	6, 24 or 90	213/182TC 215C/184TC
EUM215-W	1.375	7-1/2	95	37	3600	6, 24 or 90	213TC/215TC

EUM-W Series Enclosed UniModule

EUM-W-2030 Clutch/Brake Combination—Base Mounted

SIZE 50/180

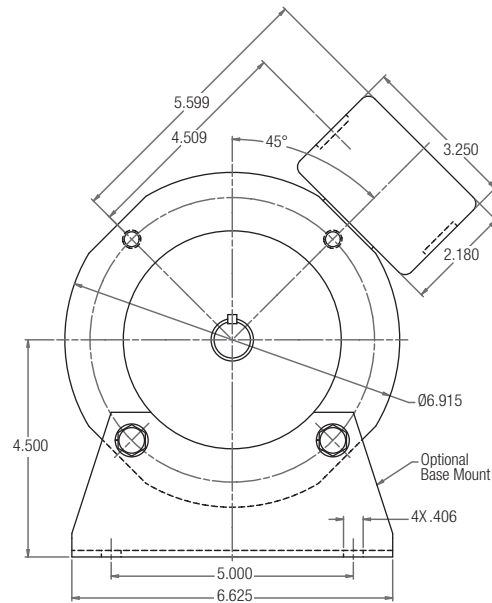
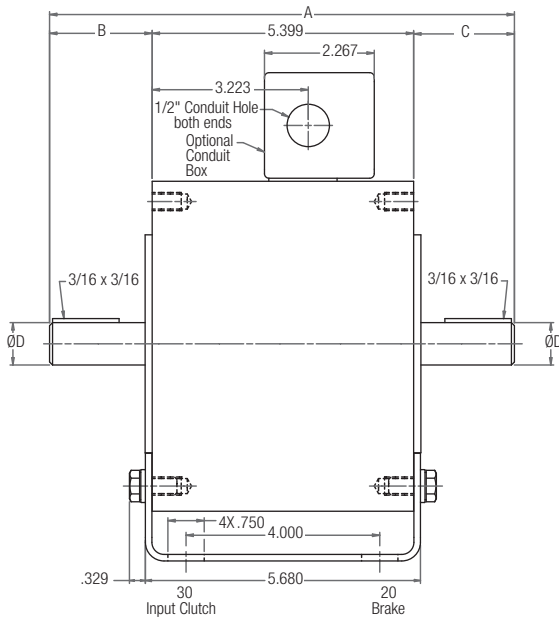

Note: Washdown UniModules (EUM-W) do not have a finned housing.

SIZE 210

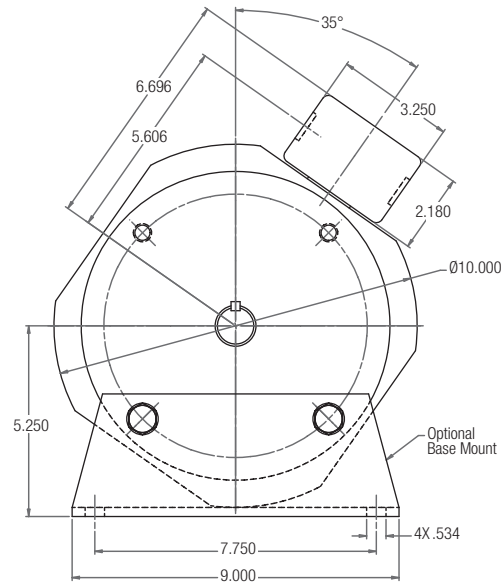
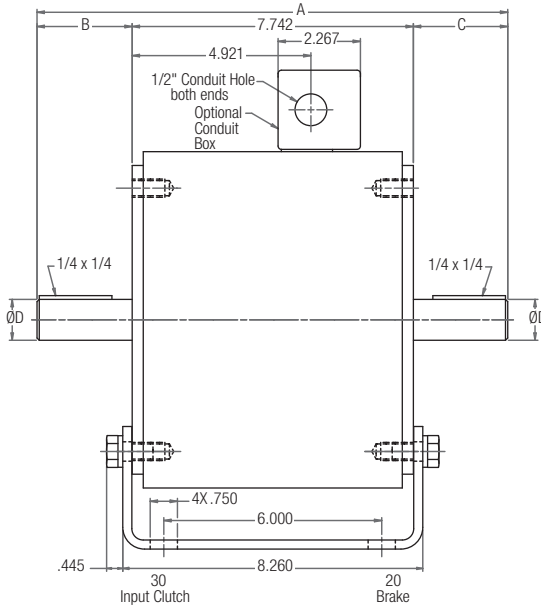

Dimensions All dimensions are nominal, unless otherwise noted.

Size	A	B	C	D
50	9.435	2.038	1.997	0.625
180	9.600	2.119	2.081	0.875
210	12.961	2.620	2.598	1.125

Specifications

For standard NEMA frame dimensions, see page G-3.

UniModule Size	Shaft Dia.	Horsepower	Static Torque lb. ft.	CPM@1750 RPM	Max. RPM	Voltage DC	NEMA Frame Size
EUM50-W	5/8"	1/4-3/4	16	125	3600	6, 24 or 90	56C/48Y
EUM100-W	5/8"	1	30	175	3600	6, 24 or 90	56C/48Y
EUM180-W	7/8"	1-2	30	175	3600	6, 24 or 90	182C/143TC 184C/145TC
EUM210-W	1-1/8"	3-5	95	32	3600	6, 24 or 90	213/182TC 215C/184TC

Packaged Performance Products Service Parts for C-face Compatible Units

UniModules

UM Series Clutch and Clutch/Brake Combinations	SP-2
UM-C Series Ceramic Faced Clutch/Brakes	N/A
Smooth-Start Clutch/Brakes	SP-38

Electro Modules

EM Series Modular Clutches, Brakes and Motor Brakes	SP-18
---	-------

Enclosed UniModules

EUM Series Clutch and Clutch/Brake Combinations	SP-32
EUM-W Series Washdown Clutch/Brakes	SP-32



When replacing components in clutches and brakes several guidelines are appropriate. In all cases, when replacing worn friction surfaces both the components need to be replaced. In many cases, the splined hubs should be inspected and replaced if worn.

Common Replacement Practices:

EM/UM/EUM clutches

- Replace rotor and armature
- Inspect splined hub

EM/UM/EUM clutch/brakes

- Replace clutch rotor and armature
- Replace brake magnet and armature
- Inspect splined hub

A note on burnishing:

When new friction surfaces are installed it will be necessary to burnish the unit prior to returning to full production rates. Burnishing is the act of wearing in the friction faces to ensure full engagement and therefore full torque. Burnishing is achieved by simply cycling the unit under less than full load (machine empty, if possible). Most units will achieve full torque in less than 100 cycles. Refer to the service manual for more details.