

EM Series Electro Module

EM-10 Motor Clutch Module

Sizes 50, 100 and 180

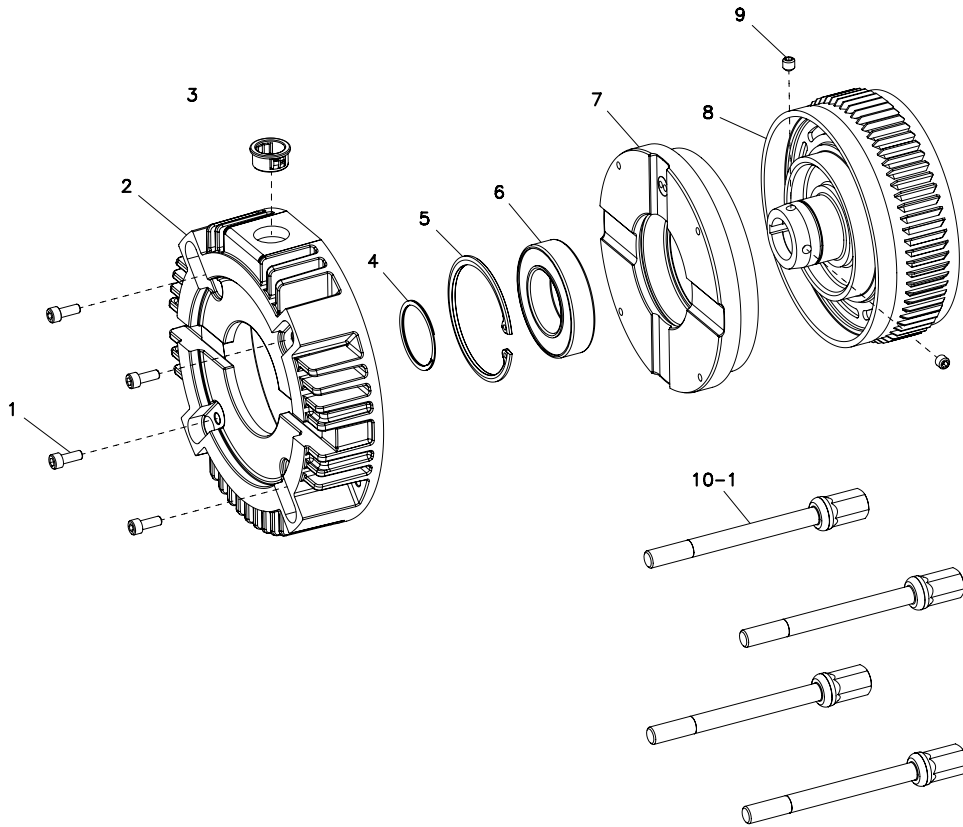

Component Parts

Item	Description	EM-50		EM-100		EM-180	
		Part No.	Qty.	Part No.	Qty.	Part No.	Qty.
1	Field Mounting Screw	797-1214	4	797-1214	4	797-1214	4
2	Housing	535-0204	1	535-0204	1	535-0204	1
3	Bushing	572-0522	1	572-0522	1	572-0522	1
4	Retaining Ring	748-0018	1	748-0018	1	748-0018	1
5	Retaining Ring	748-0561	1	748-0561	1	748-0561	1
6	Bearing	166-0150	1	166-0150	1	166-0150	1
7	Field Assembly		1		1		1
	6 Volt	5370-451-201		5370-451-206		5370-451-206	
	24 Volt	5370-451-203		5370-451-208		5370-451-208	
	90 Volt	5370-451-204		5370-451-209		5370-451-209	
8	Rotor Assembly	5370-751-019	1	5370-751-049	1	5370-751-051	1
9	Set Screw	797-1098	2	797-0069	2	797-0069	2
10	Mounting Accessory	5370-101-075	1	5370-101-075	1	5370-101-075	1
	10-1 Tie Bolt	825-0014	4	825-0014	4	825-0014	4

Refer to Service Manual P-273-5-WE.

These units meet the standards of UL 508 and are listed under guide card #NMTR2, file #59164.



Service Parts

EM Series Electro Module

EM-10 Motor Clutch Module

Size 210

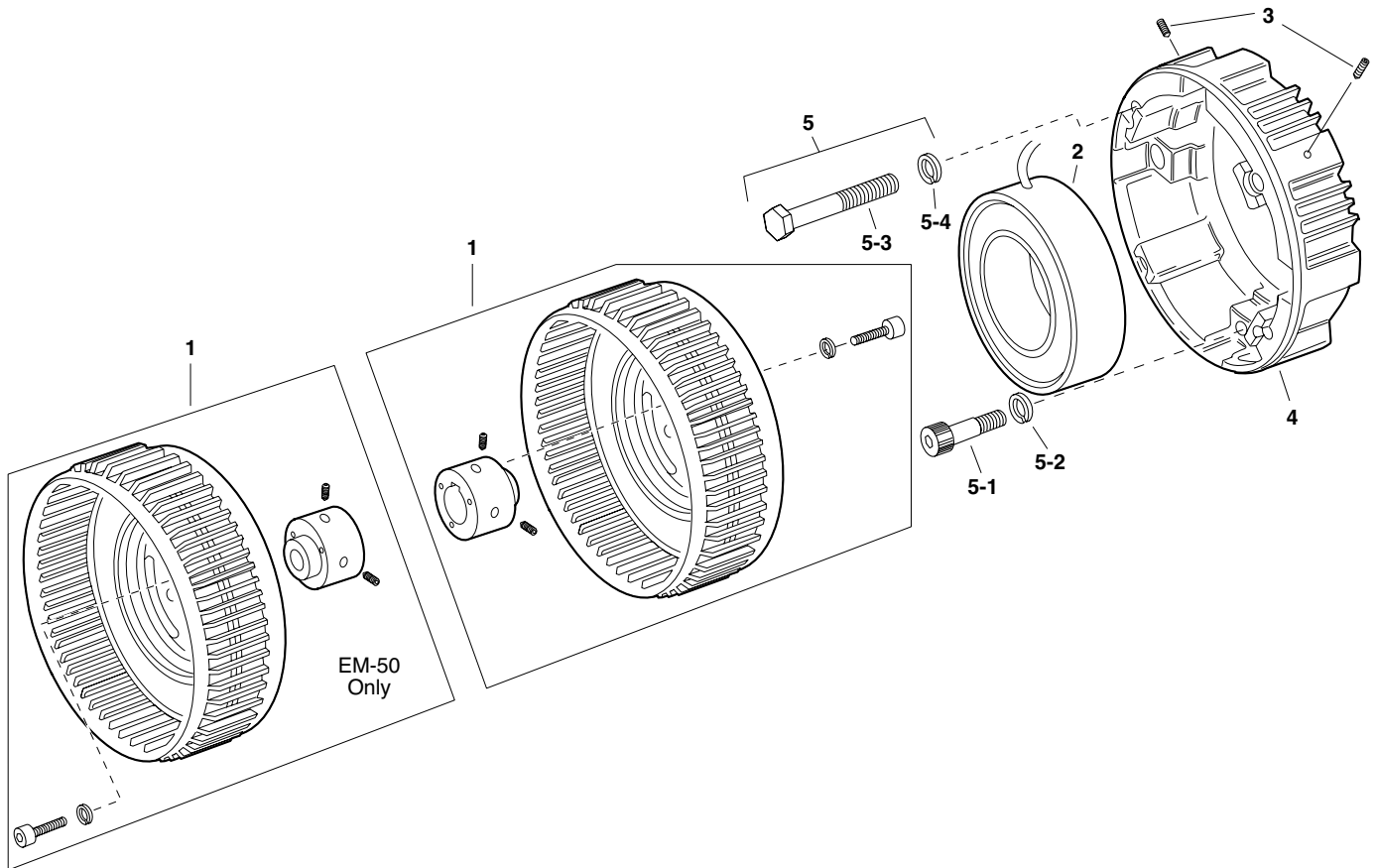

Component Parts

EM-210			
Item	Description	Part No.	Qty.
1*	Rotor Assembly w/fan & hub	5371-751-005	1
	Field		1
2	6 volt	5371-451-010	
	24 volt	5371-451-013	
	90 volt	5371-451-011	
3	Setscrew	797-0471	4
4	Adapter	104-0096	1
	Mounting Accessory	5371-101-008	1
5	5-1 Capscrew	797-1078	4
	5-2 Lockwasher	950-0101	4
	5-3 Capscrew	797-1075	4
	5-4 Lockwasher	950-0032	4

*Shipped Assembled
 Refer to Service Manual P-0213-WE.
 These units meet the standards of UL 508 and are listed under guide card #NMTR2, file #59164.



Service Parts

EM Series Electro Module

EM-20 Brake Module

Sizes 50, 100 and 180

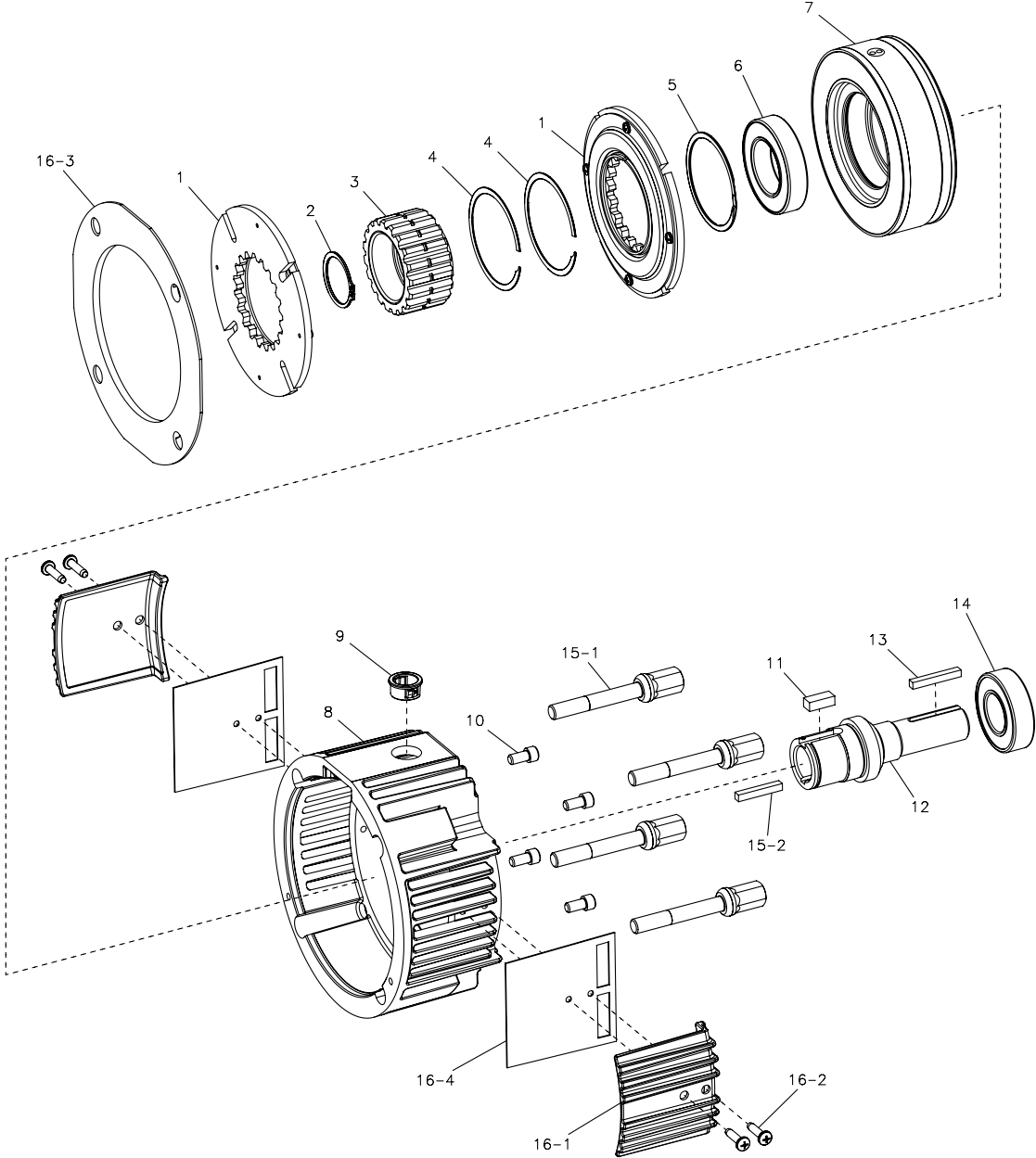

Service Parts

EM Series Electro Module

EM-20 Brake Module

Sizes 50, 100 and 180

Component Parts

Item	Description	EM-50		EM-100		EM-180	
		Part No.	Qty.	Part No.	Qty.	Part No.	Qty.
1	Armature Assembly	5370-111-022	2	5370-111-013	2	5370-111-013	2
2	Retaining Ring	748-0445	1	748-0676	1	748-0676	1
3	Armature Hub	540-1638	1	540-2038	1	540-2038	1
4	Armature Hub Retaining Ring			748-0450	2	748-0450	2
5	Retaining Ring	748-2044	1	748-0101	1	748-0101	1
6	Ball Bearing	166-0143	1	166-0150	1	166-0150	1
	Magnet Assembly		1		1		1
7	6 Volt	5370-631-201		5370-631-216		5370-631-216	
	24 Volt	5370-631-203		5370-631-218		5370-631-218	
	90 Volt	5370-631-204		5370-631-219		5370-631-219	
8	Housing	535-0206	1	535-0206	1	535-0206	1
9	Bushing	572-0522	1	572-0522	1	572-0522	1
10	Magnet Mounting Screw	797-0077	4	797-1358	4	797-1358	4
11	Key	590-0043	1	590-0084	1	590-0084	1
12	Shaft	798-0299	1	798-0302	1	798-0305	1
13	Key	590-0029	1	590-0029	1	590-0029	1
14	Ball Bearing	166-0143	1	166-0143	1	166-0143	1
	Mounting Accessory	5370-101-077	1	5370-101-077	1	5370-101-077	1
15	15-1 Tie Bolt	825-0013	4	825-0013	4	825-0013	4
	15-2 Key	590-0142	1	590-0142	1	590-0142	1
	Cover Kit (Optional, for brake only)	5370-101-082	1	5370-101-082	1	5370-101-082	1
16a	16-1 Vent Cover	258-1227	2	258-1227	2	258-1227	2
	16-2 Screw	797-1562	4	797-1562	4	797-1562	4
	16-3 Cover Plate	287-0135	1	287-0135	1	287-0135	1
	16-4 Gasket	495-0042	2	495-0042	2	495-0042	2
	Cover Kit (Optional, for clutch/brake combination)	5370-101-076	1	5370-101-076	1	5370-101-076	1
16b	16-1 Vent Cover	258-1227	2	258-1227	2	258-1227	2
	16-2 Screw	797-1562	4	797-1562	4	797-1562	4
	16-4 Gasket	495-0042	2	495-0042	2	495-0042	2

Refer to service manual P-273-5-WE.

These units meet the standards of UL 508 and are listed under guide card #NMTR2, file #59164.



Service Parts

EM Series Electro Module

EM-20 Brake Module

Sizes 210 and 215

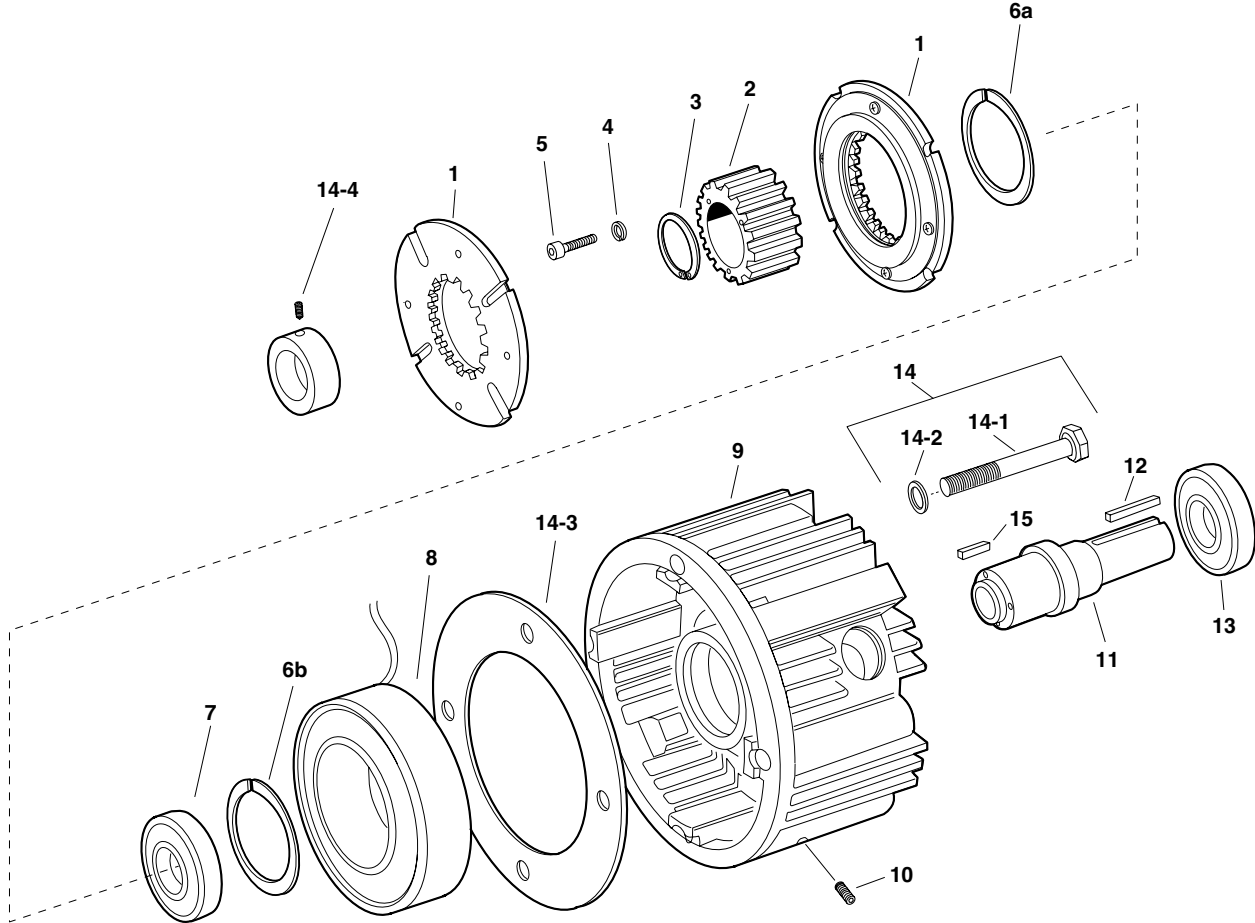

Service Parts

EM Series Electro Module

EM-20 Brake Module Sizes 210 and 215

Component Parts

Item	Description	EM-210		EM-215	
		Part No.	Qty.	Part No.	Qty.
1	Armature	5371-111-005	2	5371-111-005	1
2	Armature Hub	540-2053	1	540-2039	1
3	Retaining Ring				
4	Lockwasher	950-0372	6	950-0372	6
5	Capscrew	797-0081	6	797-008	6
6a	Retaining Ring	748-0112	1	748-0112	1
6b	Retaining Ring			748-2002	1
7	Ball Bearing	166-0142	1	166-0142	1
	Magnet		1		
8	6 Volt	5371-631-002			
	24 Volt	5371-631-005		5371-631-005	1
	90 Volt	5371-631-003		5371-631-003	1
9	Housing	535-0033	1	535-0033	1
10	Setscrew	797-0103	4	797-0103	4
11	Shaft	798-0050	1	798-0268	1
12	Key - Output	590-0019	1	590-0124	1
13	Ball Bearing	166-0144	1	166-0144	1
	Mounting Accessory	5371-101-007	1	5371-101-007	1
14	14-1 Capscrew	797-1081	4	797-1081	4
	14-2 Washer	950-0033	4	950-0033	4
	14-3 Spacer				
	14-4 Collar	266-0003	1	266-0003	1
15	Key				
	Key Accessory - Input	5371-101-043	1	5371-101-044	1

Refer to Service Manual P-0213-WE.
These units meet the standards of UL 508 and are listed under guide card #NMTR2, file #59164.



Service Parts

EM Series Electro Module

EM-20MB Motor Brake Module

Sizes 50 and 180

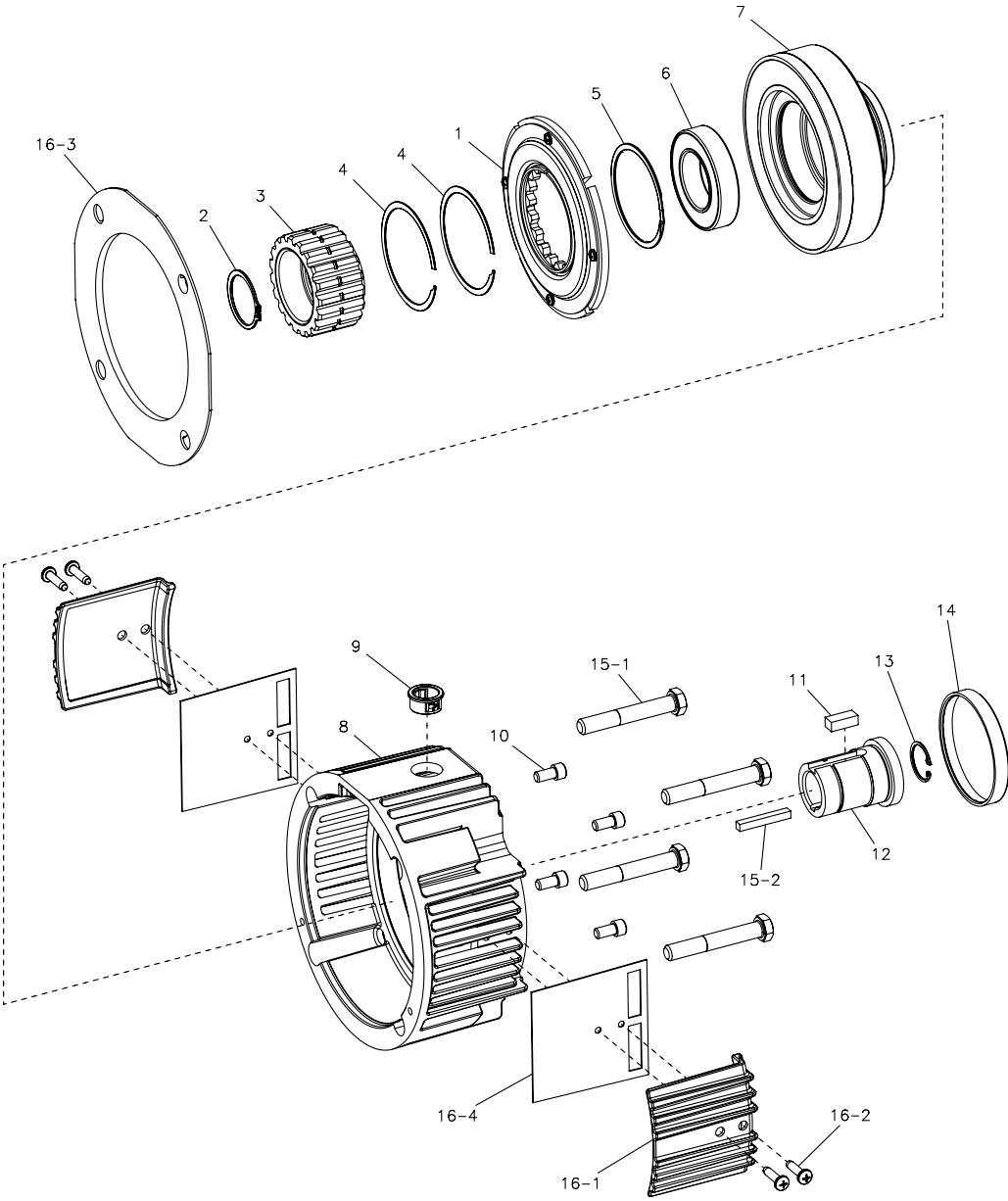

Service Parts

EM Series Electro Module

EM-20MB Motor Brake Module

Sizes 50 and 180

Component Parts

Item	Description	EM-50		EM-180	
		Part No.	Qty.	Part No.	Qty.
1	Armature Assembly	5370-111-022	1	5370-111-013	1
2	Retaining Ring	748-0445	1	748-0676	1
3	Armature Hub	540-1638	1	540-2038	1
4	Armature Hub Retaining Ring			748-0450	2
5	Retaining Ring	748-2044	1	748-0101	1
6	Ball Bearing	166-0143	1	166-0150	1
	Magnet Assembly		1		1
7	6 Volt	5370-631-201		5370-631-216	
	24 Volt	5370-631-203		5370-631-218	
	90 Volt	5370-631-204		5370-631-219	
8	Housing	535-0206	1	535-0206	1
9	Bushing	572-0522	1	572-0522	1
10	Magnet Mounting Screw	797-0077	4	797-1358	4
11	Key	590-0043	1	590-0084	1
12	Hub	540-2076	1	540-2078	1
13	Retaining Ring	748-0556	1	748-0555	1
14	Cap	248-1004	1	248-1004	1
	Mounting Accessory	5370-101-081	1	5370-101-081	1
15	15-1 Tie Bolt	797-1563	4	797-1563	4
	15-2 Key	590-0029	1	590-0029	1
	Cover Kit (Optional)	5370-101-082	1	5370-101-082	1
16	16-1 Vent Cover	258-1227	2	258-1227	2
	16-2 Screw	797-1562	4	797-1562	4
	16-3 Cover Plate	287-0135	1	287-0135	1
	16-4 Gasket	495-0042	2	495-0042	2

Refer to service manual P-273-5-WE.

These units meet the standards of UL 508 and are listed under guide card #NMTR2, file #59164.



Service Parts

EM Series Electro Module

20MB Motor Brake Module

Size 210

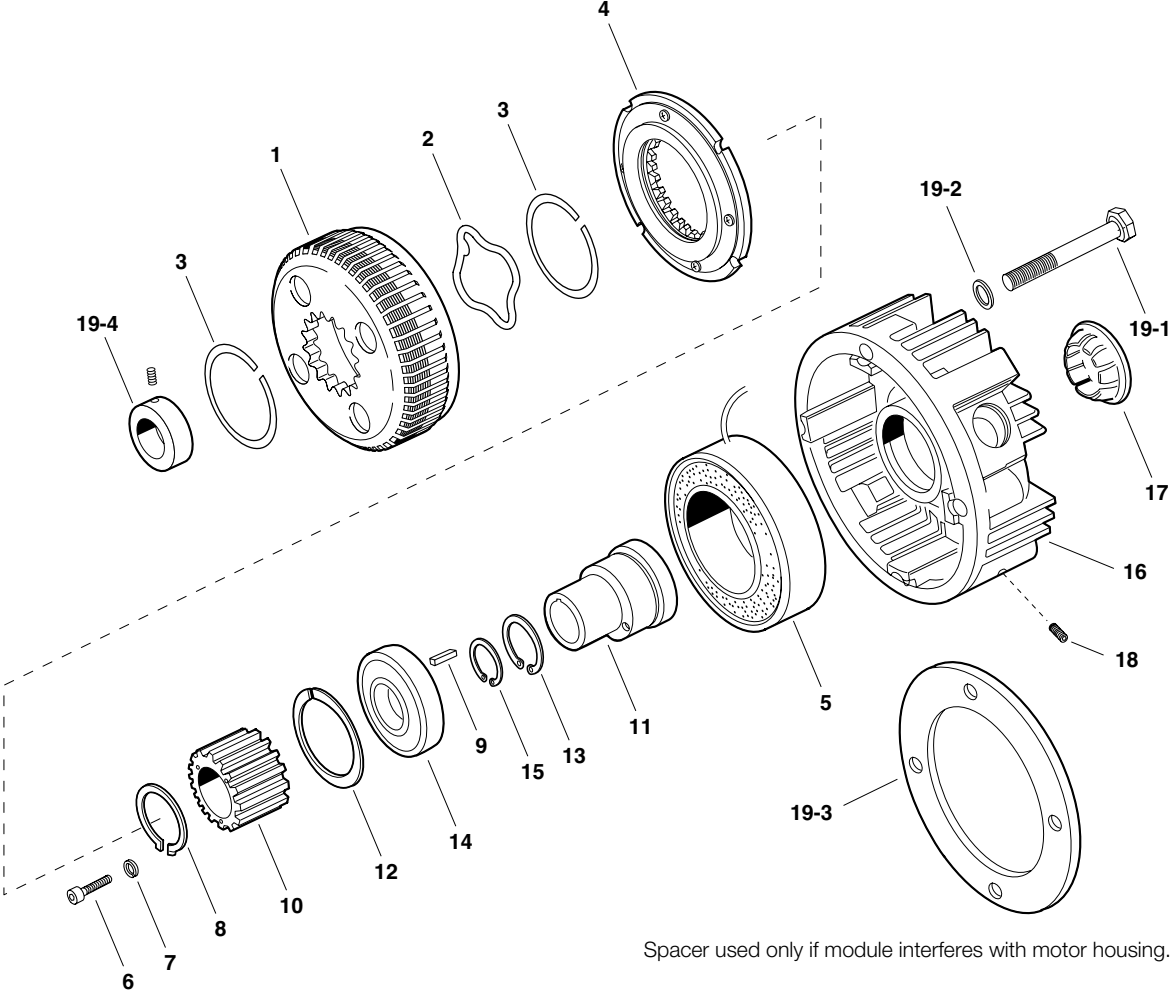

Spacer used only if module interferes with motor housing.

Service Parts

EM Series Electro Module

20MB Motor Brake Module

Size 210

Component Parts

EM-210			
Item	Description	Part No.	Qty.
1	Fan Assembly	748-1052	1
2	Follow-up Spring	808-0109	1
3	Retaining Ring	748-0455	2
4	Armature	5371-111-005	1
	Magnet		1
5	6 Volt	5371-631-002	
	24 Volt	5371-631-005	
	90 Volt	5371-631-003	
6	Capscrew	797-0081	6
7	Lockwasher	950-0372	6
8	Retaining Ring		
9	Key		
10	Splined Hub	540-2041	1
11	Hub	540-1020	1
12	Retaining Ring	748-0112	1
13	Retaining Ring		
14	Bearing	166-0142	1
15	Retaining Ring	748-0554	1
16	Housing	535-0050	1
17	Plug	680-0027	1
18	Setscrew	797-0103	4
	Mounting Accessory	5371-101-007	1
19	19-1 Capscrew	797-1081	4
	19-2 Lockwasher	950-0033	4
	19-3 Spacer		
	19-4 Collar	266-0003	1
	Key Accessory - Input	5371-101-043	1

Refer to service manual P-273-5-WE.

These units meet the standards of UL 508 and are listed under guide card #NMTR2, file #59164.



Service Parts

EM Series Electro Module

30 Motor Clutch Module

Sizes 50, 100 and 180

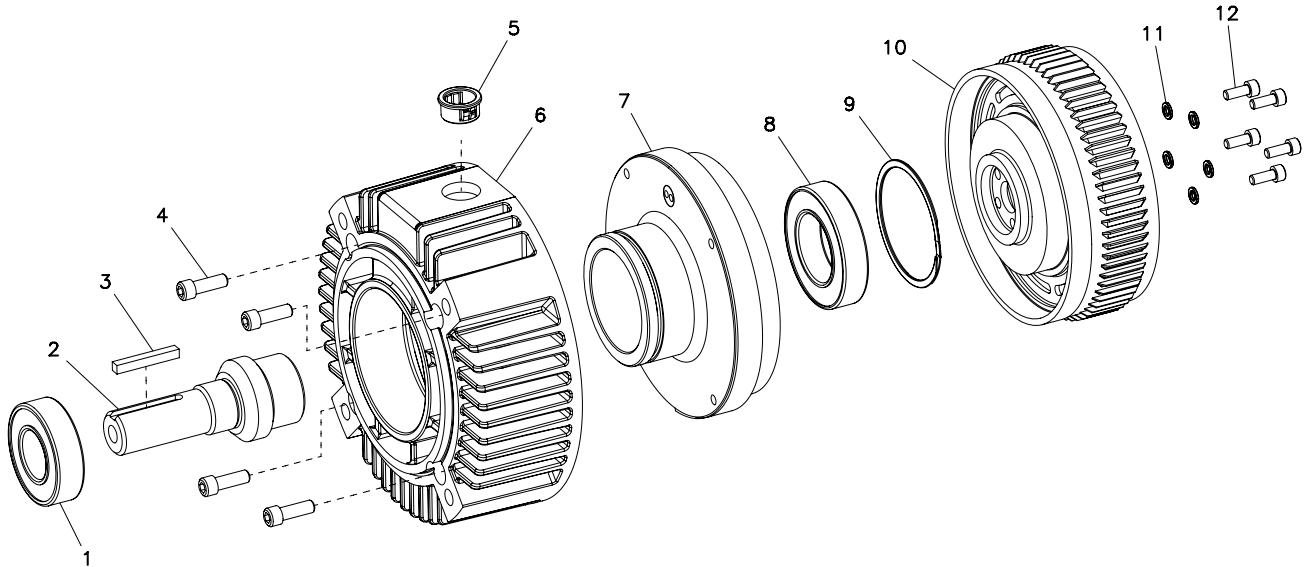

Component Parts

Item	Description	EM-50		EM-100		EM-180	
		Part No.	Qty.	Part No.	Qty.	Part No.	Qty.
1	Ball Bearing	166-0143	1	166-0143	1	166-0143	1
2	Shaft	798-0300	1	798-0303	1	798-0306	1
3	Key	590-0029	1	590-0029	1	590-0029	1
4	Field Mounting Screw	797-0077	4	797-0077	4	797-0077	4
5	Bushing	572-0522	1	572-0522	1	572-0522	1
6	Housing	535-0205	1	535-0205	1	535-0205	1
	Field Assembly		1		1		1
7	6 Volt	5370-451-211		5370-451-216		5370-451-216	
	24 Volt	5370-451-213		5370-451-218		5370-451-218	
	90 Volt	5370-451-214		5370-451-219		5370-451-219	
8	Ball Bearing	166-0143	1	166-0150	1	166-0150	1
9	Retaining Ring	748-2044	1	748-0101	1	748-0101	1
10	Rotor Assembly	5370-751-006	1	5370-751-053	1	5370-751-053	1
11	Washer	950-0436	4	950-0436	5	950-0436	5
12	Screw	797-1294	4	797-1214	5	797-1214	5

Refer to service manual P-273-5-WE.

These units meet the standards of UL 508 and are listed under guide card #NMTR2, file #59164.



Service Parts

EM Series Electro Module

30 Motor Clutch Module

Size 210

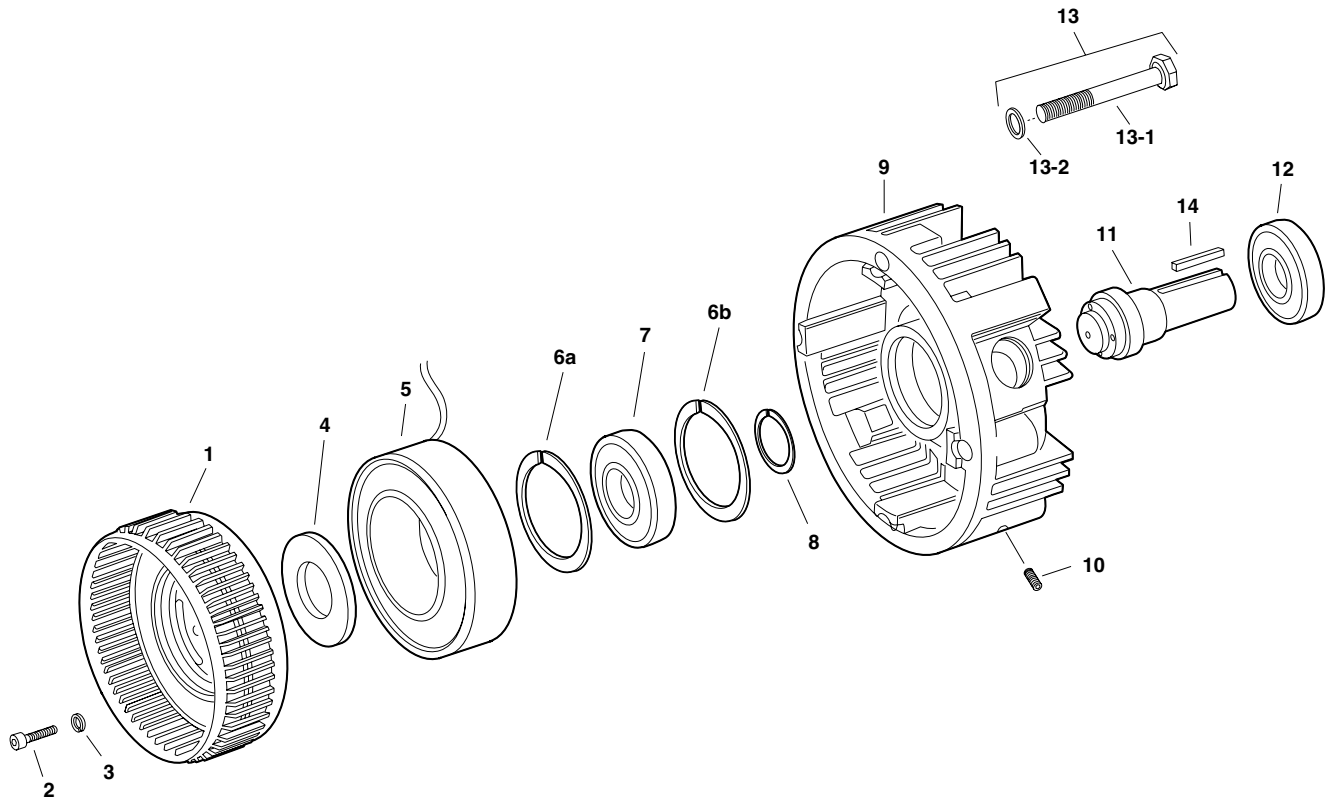

Component Parts

EM-210			
Item	Description	Part No.	Qty.
1	Rotor Assembly w/fan	5371-751-007	1
2	Capscrew	797-0083	6
3	Lockwasher	950-0372	6
4	Spacer	807-0061	1
	Field (with housing EM-50-30 only)		1
5	6 volt	5371-451-002	
	24 volt	5371-451-005	
	90 volt	5371-451-003	
6a	Retaining Ring	748-0112	1
6b	Retaining Ring		
7	Ball Bearing	166-0142	1
8	Retaining Ring		
9	Housing	535-0129	1
10	Setscrew	797-0471	4
11	Shaft	798-0123	1
12	Ball Bearing	166-0144	1
	Mounting Accessory	5371-101-010	1
13	13-1 Capscrew	797-1075	4
	13-2 Lockwasher	950-0032	4
14	Key	590-0019	1

Refer to service manual P-273-5-WE.
These units meet the standards of UL 508 and are listed under guide card #NMTR2, file #59164.



Service Parts

EM Series Electro Module

40 Output Clutch Module

Sizes 50, 100 and 180

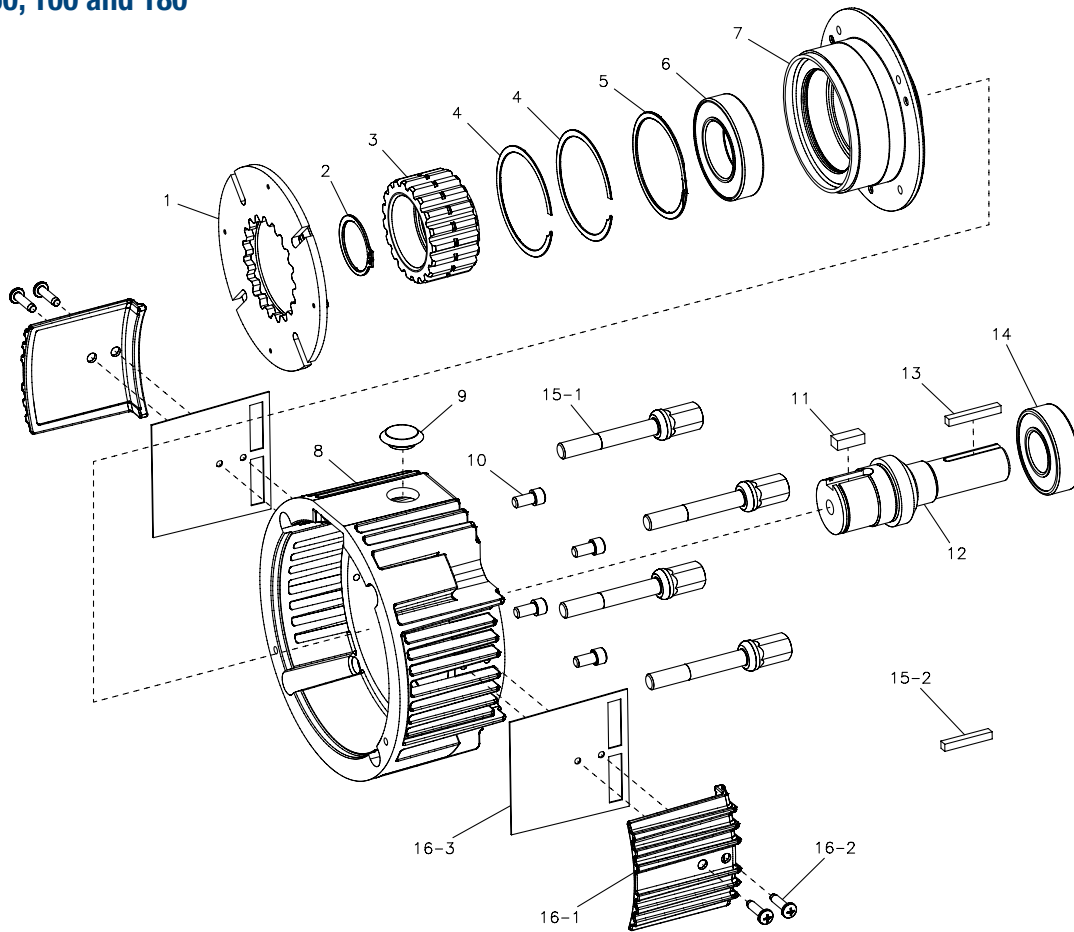

Component Parts

Item	Description	EM-50		EM-100		EM-180	
		Part No.	Qty.	Part No.	Qty.	Part No.	Qty.
1	Armature Assembly	5370-111-022	1	5370-111-013	1	5370-111-013	1
2	Retaining Ring	748-0445	1	748-0676	1	748-0676	1
3	Armature Hub	540-1638	1	540-2038	1	540-2038	1
4	Armature Hub Retaining Ring			748-0450	2	748-0450	2
5	Retaining Ring	748-2044	1	748-0101	1	748-0101	1
6	Ball Bearing	166-0143	1	166-0150	1	166-0150	1
7	Bearing Hub	690-0276	1	690-0278	1	690-0278	1
8	Housing	535-0207	1	535-0207	1	535-0207	1
9	Plug	680-0037	1	680-0037	1	680-0037	1
10	Hub Mounting Screw	797-0077	4	797-1358	4	797-1358	4
11	Key	590-0043	1	590-0084	1	590-0084	1
12	Shaft	798-0298	1	798-0301	1	798-0304	1
13	Key	590-0029	1	590-0029	1	590-0029	1
14	Ball Bearing	166-0143	1	166-0143	1	166-0143	1
	Mounting Accessory	5370-101-077	1	5370-101-077	1	5370-101-077	1
15	15-1 Tie Bolt	825-0013	4	825-0013	4	825-0013	4
	15-2 Key	590-0142	1	590-0142	1	590-0142	1
	Cover Kit (Optional)	5370-101-076	1	5370-101-076	1	5370-101-076	1
16	16-1 Cover	258-1227	2	258-1227	2	258-1227	2
	16-2 Screw	797-1562	4	797-1562	4	797-1562	4
	16-3 Gasket	495-0042	2	495-0042	2	495-0042	2

Refer to service manual P-273-5-WE.
These units meet the standards of UL 508 and are listed under guide card #NMTR2, file #59164.



Service Parts

EM Series Electro Module

40 Output Clutch Module

Size 210

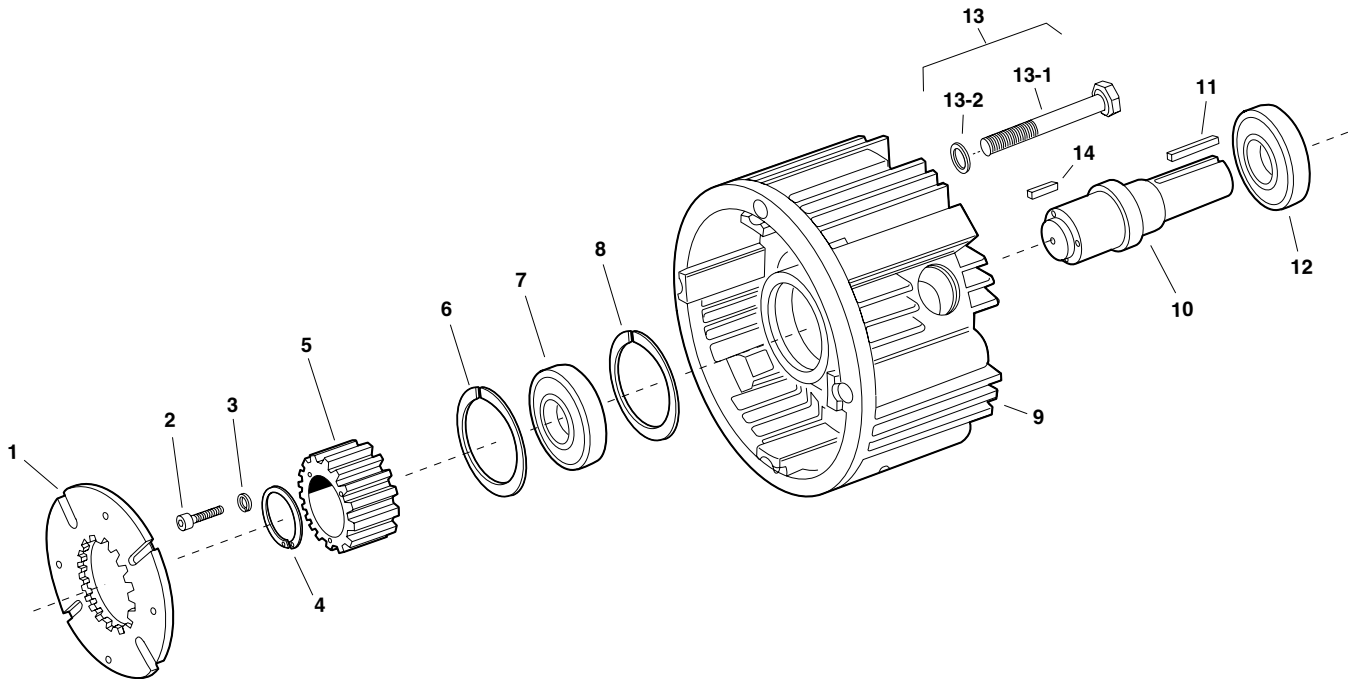

Component Parts

EM-210			
Item	Description	Part No.	Qty.
1	Armature	5371-111-005	1
2	Capscrew	797-0081	1
3	Lockwasher	950-0372	6
4	Retaining Ring		
5	Hub	540-2053	1
6	Retaining Ring	748-0112	1
7	Ball Bearing	166-0142	1
8	Retaining Ring		
9	Housing	535-0034	1
10	Shaft	798-0051	1
11	Key	590-0019	1
12	Ball Bearing	166-0144	1
13	Mounting Accessory		
	13-1 Capscrew		
	13-2 Lockwasher		
14	Key		
	Key Accessory - Input	5371-101-043	1

Refer to service manual P-273-5-WE.

These units meet the standards of UL 508 and are listed under guide card #NMTR2, file #59164.



Service Parts