

EUM/EUM-W Series Electro Module

EUM-1020 Clutch/Brake Combination EUM-W-1020 Clutch/Brake Combination Sizes 50, 100, 180, 210 and 215

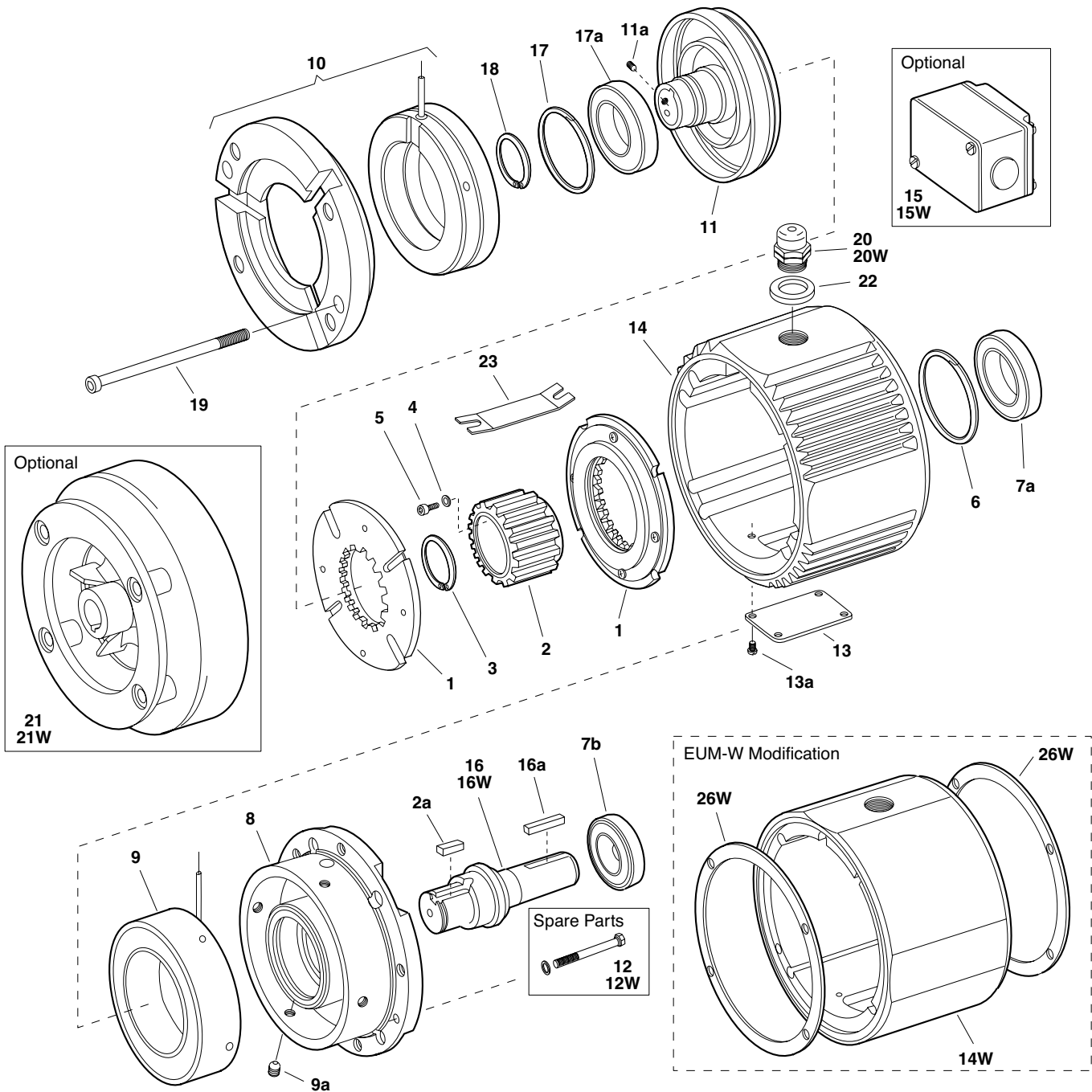

Service Parts

EUM/EUM-W Series Electro Module

EUM-1020 Clutch/Brake Combination EUM-W-1020 Clutch/Brake Combination Sizes 50, 100, 180, 210 and 215

Component Parts

Item	Description	EUM-50		EUM-100		EUM-180		EUM-210		EUM-215	
		Part No.	Qty.	Part No.	Qty.	Part No.	Qty.	Part No.	Qty.	Part No.	Qty.
1	Armature Assembly	5370-111-011	2	5370-111-013	2	5370-111-013	2	5371-111-005	2	5371-111-005	2
2	Armature Hub	540-1638	1	540-1642	1	540-1642	1	540-2053	1	540-2053	1
2a	Key	590-0043	1	590-0084	1	590-0084	1				
3	Retaining Ring	748-0445	1	748-0676	1	748-0676	1				
4	Lockwasher							950-0121	6	950-0121	6
5	Capscrew							797-0081	6	797-0081	6
6	Retaining Ring	748-0113	2	748-0101	1	748-0101	1	748-0112	1	748-0112	1
7a	Ball Bearing	166-0149	1	166-0101	1	166-0101	1	166-0142	1	166-0142	1
7b	Ball Bearing	166-0155	1	166-0143	1	166-0143	1	166-0144	1	166-0144	1
8	Endbell/Brake	456-1014	1	456-1019	1	456-1019	1	456-1017	1	456-1017	1
	Brake Magnet		1		1		1		1		1
9	6 volt	5370-631-037		5370-631-002		5370-631-002		5371-631-002		5371-631-002	
	24 volt	5370-631-038		5370-631-005		5370-631-005		5371-631-005		5371-631-005	
	90 volt	5370-631-036		5370-631-003		5370-631-003		5371-631-003		5371-631-003	
9a	Set Screws	797-0471	4	797-0471	4	797-0471	4	797-0471	4	797-0471	4
	Clutch Field/Endbell Assembly		1		1		1		1		1
10	6 volt	5370-451-077		5370-451-086		5370-451-086		5371-451-033		5371-451-033	
	24 volt	5370-451-078		5370-451-087		5370-451-087		5371-451-034		5371-451-034	
	90 volt	5370-451-076		5370-451-085		5370-451-085		5371-451-032		5371-451-032	
11	Rotor/Hub Assembly	5370-751-023	1	5370-751-035	1	5370-751-024	1	5371-751-014	1	5371-751-033	1
11a	Set Screws	797-1098	2	797-0069	2	797-0069	2	797-1098	2	797-1098	2
12	Mounting Accessory Kit							5371-101-024	1	5371-101-024	1
13	Cover Plate	686-1055	1	686-1055	1	686-1055	1	686-1055	1	686-1055	1
13a	Cover Plate Screws	797-0575	4	797-0575	4	797-0575	4	797-0575	4	797-0575	4
14	Center Housing							535-0177	1	535-0177	1
15	Conduit Box (optional)							5370-101-042	1	5370-101-042	1
16	Shaft							798-0051	1	798-0254	1
16a	Key	590-0029	1	590-0029	1	590-0029	1	590-0019	1	590-0124	1
17	Retaining Ring	748-0101	2	748-0101	1	748-0101	1	748-0558	1	748-0558	1
17a	Ball Bearing	166-0150	1	166-0300	1	166-0300	1	166-0168	1	166-0168	1
18	Retaining Ring	748-0018	1	748-0018	1	748-0018	1	748-0067	1	748-0067	1
19	Assembly Bolts	797-1433	2	797-1433	2	797-1433	2	797-1438	2	797-1438	2
20	Connector							280-0038	1	280-0038	1
21	Accessory Fan (optional)							5371-101-029	1	N/A	
22	Washer	950-0441	1	950-0441	1	950-0441	1	950-0441	1	950-0441	1
23	Insulator	572-0327	1	572-0327	1	572-0327	1	572-0327	1	572-0327	1
EUM-W Unique Parts											
12W	Washdown Mounting Kit	5370-101-052	1	5370-101-052	1	5370-101-052	1	5371-101-028	1	5371-101-028	1
14W	Center Housing for Washdown	535-0181	1	535-0181	1	535-0181	1	535-0182	1	535-0182	1
15W	Conduit Box Kit	5370-101-045	1	5370-101-045	1	5370-101-045	1	5370-101-045	1	5370-101-045	1
16W	Shaft	798-0263	1	798-0265	1	798-0262	1	798-0259	1	798-0267	1
20W	Conduit Connector	280-0058	1	280-0058	1	280-0058	1	280-0058	1	280-0058	1
21W	Fan Kit (optional)	5370-101-060	1	5370-101-060	1	5370-101-061	1	5371-101-033	1	N/A	
26W	Gasket/Seal Repair Kit	5370-101-058	1	5370-101-058	1	5370-101-058	1	5371-101-032	1	5371-101-032	1
	Key	5370-101-072	1	5370-101-072	1	5370-101-072	1	5371-101-043	1	5371-101-044	1

Refer to service manual P-273-5-WE.
These units meet the standards of UL 508 and are listed under guide card #NMTR2, file #59164.



Service Parts

EUM Series Electro Module

EUM-1040 Clutch Combination

Size 210

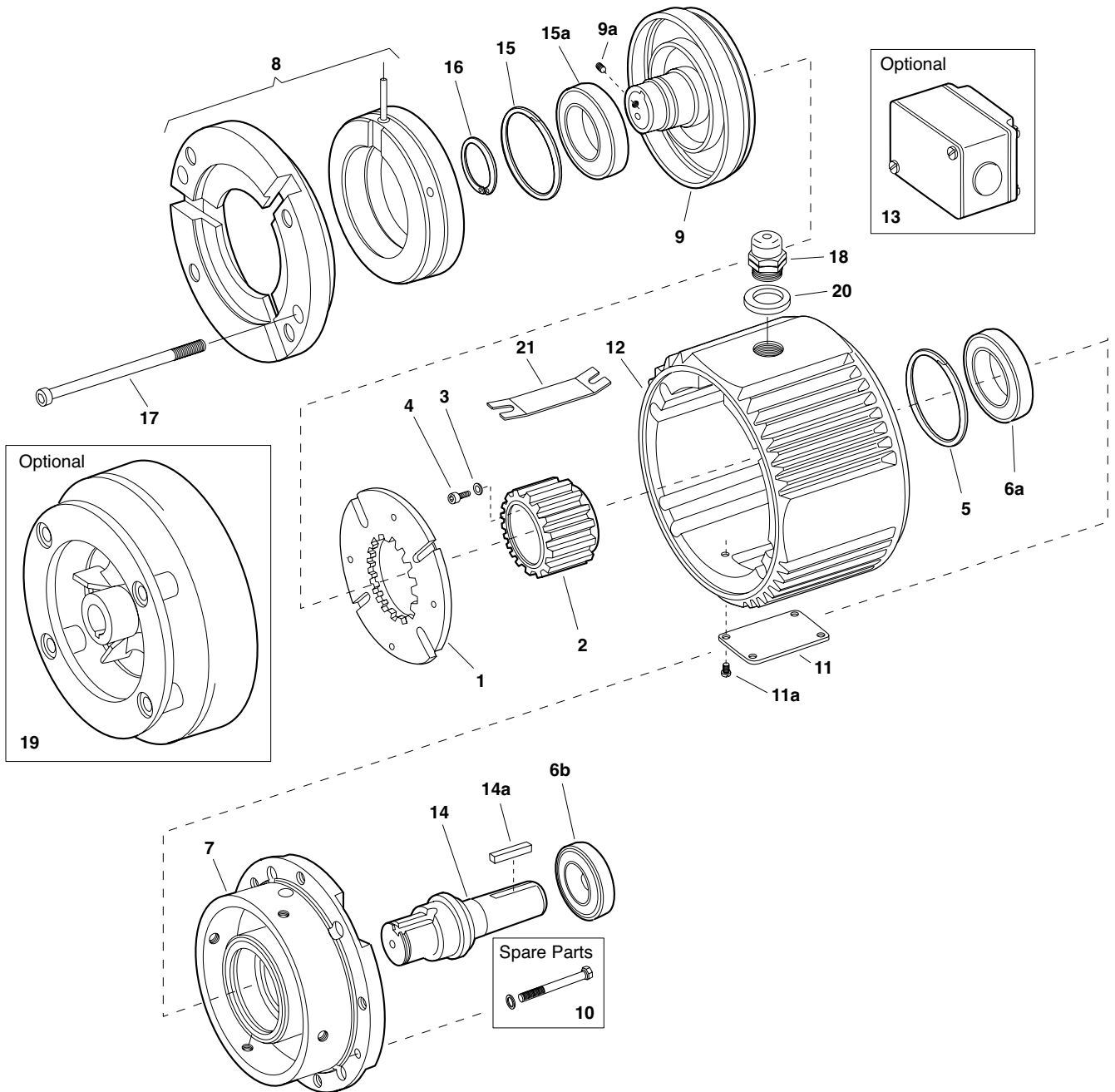

Service Parts

Component Parts

EUM-210			
Item	Description	Part No.	Qty.
1	Armature Assembly	5371-111-005	1
2	Armature Hub	540-2053	1
3	Lockwasher	950-0121	6
4	Capscrew	797-0081	6
5	Retaining Ring	748-0112	1
6a	Ball Bearing	166-0142	1
6b	Ball Bearing	166-0144	1
7	Endbell	456-1017	1
8	Clutch Field/Endbell Assembly 90 Volt	5371-451-032	1
9	Rotor/Hub Assembly	5371-751-014	1
9a	Set Screws	797-1098	2
10	Mounting Accessory Kit	5371-101-024	1
11	Cover Plate	686-1055	1
11a	Cover Plate Screws	797-0575	4
12	Center Housing	535-0177	1
13	Conduit Box (optional)	5370-101-042	1
14	Shaft	798-0051	1
14a	Key	590-0019	1
15	Retaining Ring	748-0558	1
15a	Ball Bearing	166-0168	1
16	Retaining Ring	748-0067	1
17	Assembly Bolts	797-1438	2
18	Connector	280-0038	1
19	Accessory Fan (optional)	5371-101-029	1
20	Washer	950-0441	1
21	Insulator	572-0327	1
	Key Accessory	5371-101-043	1

Refer to service manual P-273-5-WE.

These units meet the standards of UL 508 and are listed under guide card #NMTR2, file #59164.



EUM/EUM-W Series Electro Module

EUM-2030 Clutch/Brake Combination EUM-W-2030 Clutch/Brake Combination Sizes 50, 180 and 210

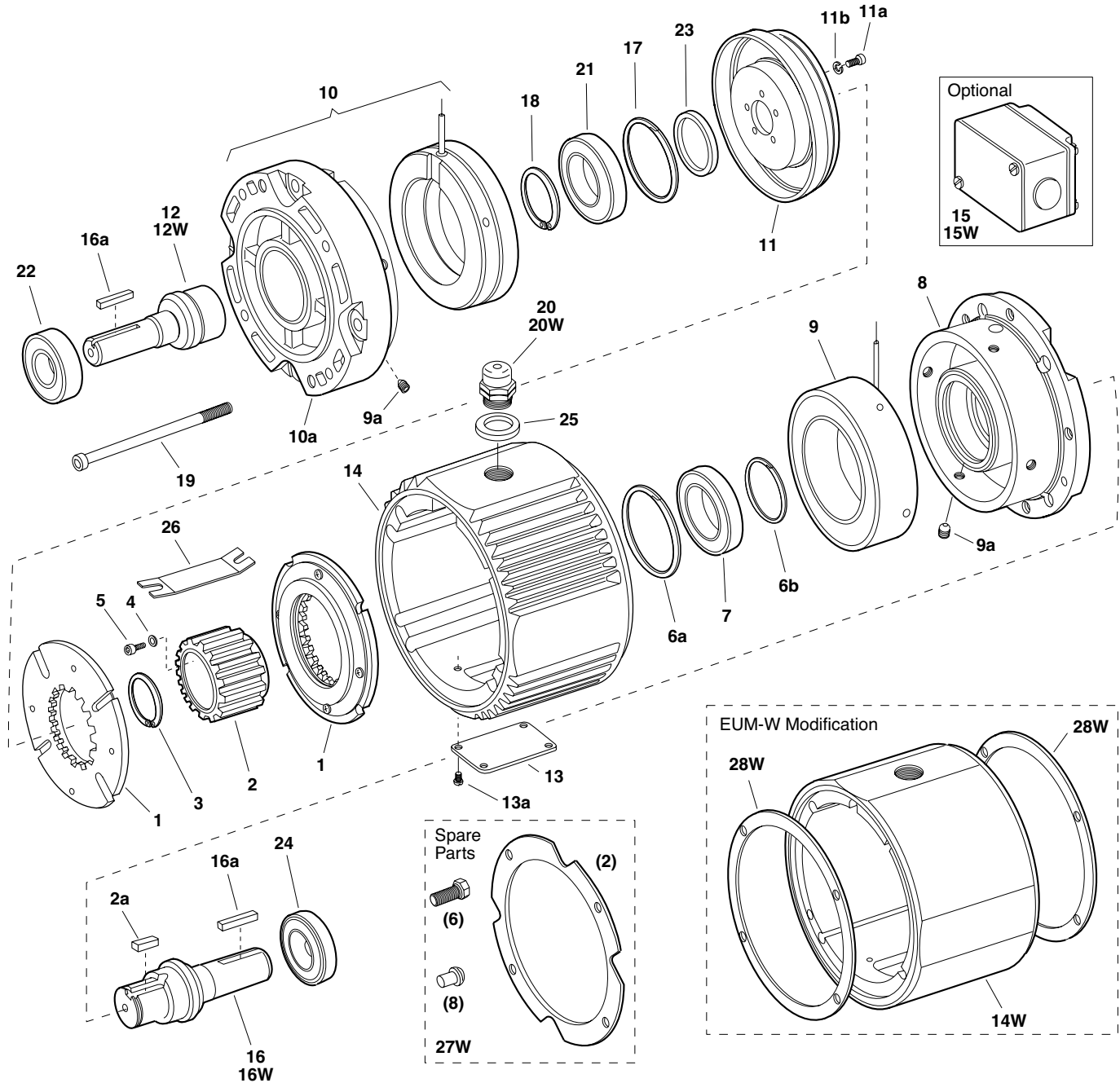

Service Parts

EUM/EUM-W Series Electro Module

EUM-2030 Clutch/Brake Combination EUM-W-2030 Clutch/Brake Combination Sizes 50, 180 and 210

Component Parts

Item	Description	EUM-50		EUM-180		EUM-210	
		Part No.	Qty.	Part No.	Qty.	Part No.	Qty.
1	Armature Assembly	5370-111-011	2	5370-111-013	2	5371-111-005	2
2	Armature Hub	540-1638	1	540-1642	1	540-2053	1
2a	Key	590-0043	1	590-0084	1		
3	Retaining Ring	748-0445	1	748-0676	1		
4	Lockwasher					950-0121	6
5	Capscrew					797-0081	6
6a	Retaining Ring	748-0113	2	748-0101	1	748-0112	1
6b	Retaining Ring					748-2002	1
7	Ball Bearing	166-0149	1	166-0101	1	166-0142	1
8	Endbell/Brake	456-1014	1	456-1019	1	456-1017	1
	Brake Magnet		1		1		1
9	6 volt	5370-631-037		5370-631-002		5371-631-002	
	24 volt	5370-631-038		5370-631-005		5371-631-005	
	90 volt	5370-631-036		5370-631-003		5371-631-003	
9a	Set Screws	797-0471	4	797-0471	4	797-0471	8
	Field (with Endbell EUM-50 and EUM-180)		1		1		1
10	6 volt	5370-451-082		5370-451-090		5371-451-002	
	24 volt	5370-451-083		5370-451-091		5371-451-005	
	90 volt	5370-451-081		5370-451-089		5371-451-003	
10a	Endbell (EUM-210 only)				456-1018	1	
11	Rotor	5370-751-033	1	5370-751-034	1	5371-751-006	1
11a	Screw	797-1294	4	797-1214	5	797-0081	6
11b	Washer	950-0102	4	950-0102	5	950-0121	6
12	Shaft/Clutch					798-0123	1
13	Cover Plate	686-1055	1	686-1055	1	686-1055	1
13a	Screws	797-0575	4	797-0575	4	797-0575	4
14	Center Housing					535-0177	1
15	Conduit Box (optional)					5370-101-042	1
16	Shaft/Brake					798-0051	1
16a	Key	590-0029	2	590-0029	2	590-0019	2
17	Retaining Ring	748-0113	2	748-0101	1	748-0112	1
18	Retaining Ring	748-0017	1			748-0202	1
19	Assembly Bolts	797-1477	2	797-1477	2	797-1476	2
20	Connector					280-0038	1
21	Bearing	166-0149	1	166-0101	1	166-0142	1
22	Bearing	166-0155	1	166-0143	1	166-0144	1
23	Spacer			807-0062	1	807-0061	1
24	Bearing	166-0155	1	166-0143	1	166-0144	1
25	Washer	950-0441	1	950-0441	1	950-0441	1
26	Insulator	572-0327	1	572-0327	1	572-0327	1
EUM-W Unique Parts							
12W	Shaft/Clutch	798-0264	1	798-0261	1	798-0260	1
14W	Center Housing for Washdown	535-0181	1	535-0181	1	535-0182	1
15W	Conduit Box Kit (optional)	5370-101-045	1	5370-101-045	1	5370-101-045	1
16W	Shaft/Brake	798-0263	1	798-0262	1	798-0259	1
20W	Conduit Connector	280-0058	1	280-0058	1	280-0058	1
27W	Washdown Mounting Kit	5370-101-051	1	5370-101-051	1	5371-101-027	1
28W	Gasket/Seal Repair Kit	5370-101-058	1	5370-101-058	1	5371-101-032	1

Refer to service manual P-273-5-WE.
These units meet the standards of UL 508 and are listed under guide card #NMTR2, file #59164.



Service Parts