

UM Series Smooth-Start UniModules

UM-1020-LK Clutch/Brake Combination

Sizes 50, 180 and 210

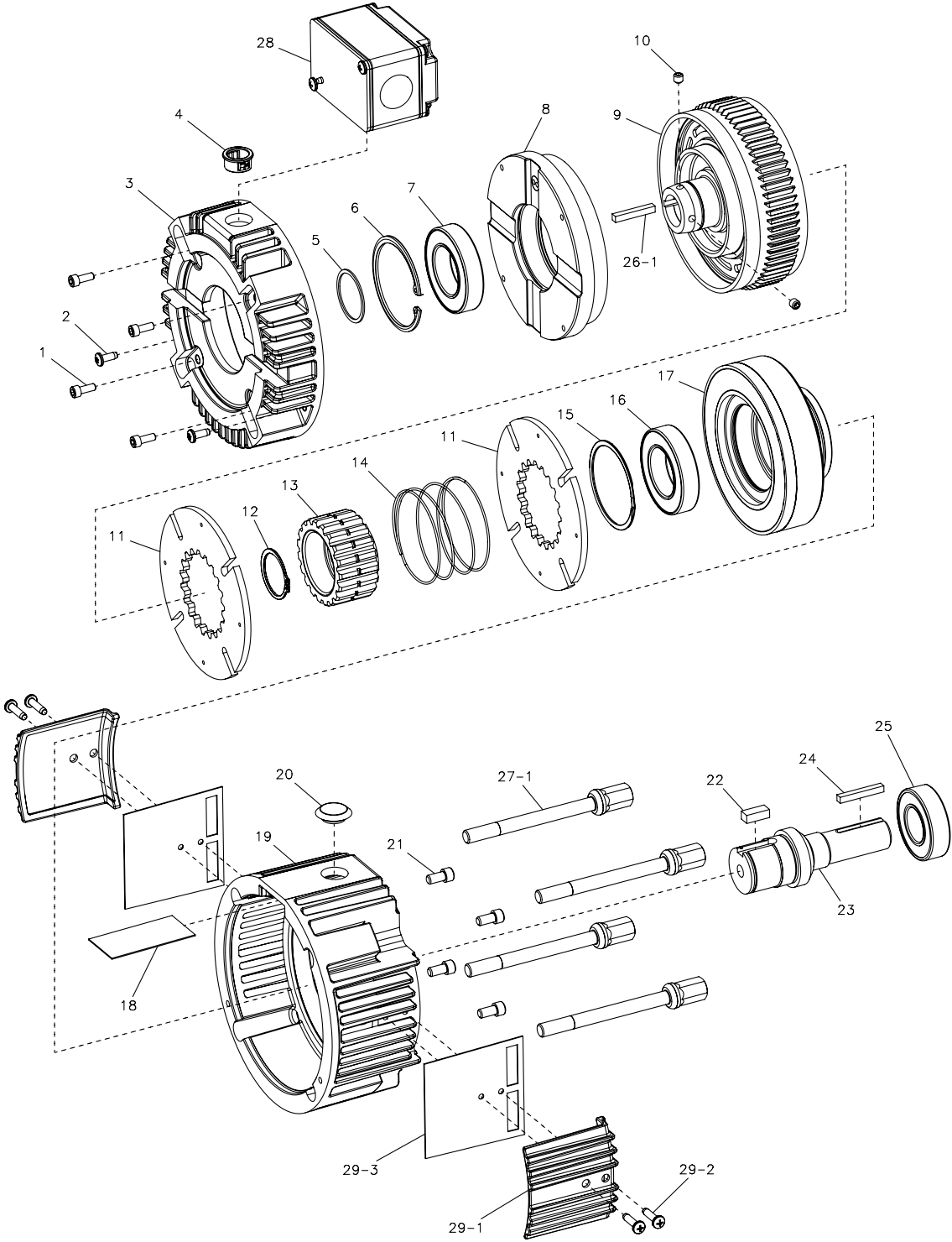

Service Parts

UM Series Smooth-Start UniModules

UM-1020-LK Clutch/Brake Combination

Sizes 50, 180 and 210

Component Parts

Item	Description	UM-50		UM-180		UM-210	
		Part No.	Qty.	Part No.	Qty.	Part No.	Qty.
1	Field Mounting Screw	797-1214	4	797-1214	4	797-1214	4
2	Screw	797-1568	2	797-1568	2	797-1568	2
3	Housing	535-0204	1	535-0204	1	535-0204	1
4	Bushing	572-0522	1	572-0522	1	572-0522	1
5	Retaining Ring	748-0018	1	748-0018	1	748-0018	1
6	Retaining Ring	748-0561	1	748-0561	1	748-0561	1
7	Ball Bearing	166-0150	1	166-0150	1	166-0150	1
8	Field Assembly 90 Volt	5370-451-204	1	5370-451-209	1	5370-451-209	1
9	Rotor Assembly	5370-751-046	1	5370-751-050	1	5370-751-051	1
10	Set Screw	797-1098	2	797-0069	2	797-0069	2
11	Armature	110-0067	2	110-0075	2	110-0075	2
12	Retaining Ring	748-0445	1	748-0676	1	748-0676	1
13	Armature Hub	540-1638	1	540-2038	1	540-2038	1
14	Spring	808-0449	1	808-0450	1	808-0450	1
15	Retaining Ring	748-2044	1	748-0101	1	748-0101	1
16	Ball Bearing	166-0143	1	166-0150	1	166-0150	1
17	Magnet Assembly 90 Volt	5370-631-214	1	5370-631-229	1	5370-631-229	1
18	Insulator	572-1029	1	572-1029	1	572-1029	1
19	Housing	535-0206	1	535-0206	1	535-0206	1
20	Plug	680-0037	1	680-0037	1	680-0037	1
21	Magnet Mounting Screw	797-0077	4	797-1358	4	797-1358	4
22	Key	590-0043	1	590-0084	1	590-0084	1
23	Shaft	798-0298	1	798-0301	1	798-0304	1
24	Key	590-0029	1	590-0029	1	590-0029	1
25	Ball Bearing	166-0143	1	166-0143	1	166-0143	1
26	Mounting Accessory	5370-101-072	1	5370-101-072	1	5370-101-072	1
	26-1 Key	590-0142	1	590-0142	1	590-0142	1
27	Mounting Accessory	5370-101-075	1	5370-101-075	1	5370-101-075	1
	27-1 Tie Bolt	825-0014	4	825-0014	4	825-0014	4
28	Conduit Box (Optional)	5370-101-042	1	5370-101-042	1	5370-101-042	1
	Cover Kit (Optional)	5370-101-076	1	5370-101-076	1	5370-101-076	1
29	29-1 Cover	258-1227	2	258-1227	2	258-1227	2
	29-2 Screw	797-1562	4	797-1562	4	797-1562	4
	29-3 Gasket	495-0042	2	495-0042	2	495-0042	2

Refer to service manual P-273-5-WE.

These units meet the standards of UL 508 and are listed under guide card #NMTR2, file #59164.



Service Parts

General Engineering Data



G

Mechanical Data Application Engineering

- Ordering Information / Standard NEMA Frame Dimensions..... G-3
- Mechanical Data / Dynamic Torque G-4
- Mechanical Data / Rotational Speed..... G-6
- Mechanical Data / Clutch Field Restraining Devices..... G-7
- Electrical Data / Coil Ratings G-8
- Electrical Data / Installation Procedure G-11
- Electrical Data / Coil Suppression & Clutch/Brake Overlap G-12
- Electrical Data / Overexcitation G-13