

UM Series UniModule

UM-1020 Clutch/Brake Combination

Sizes 50, 100 and 180

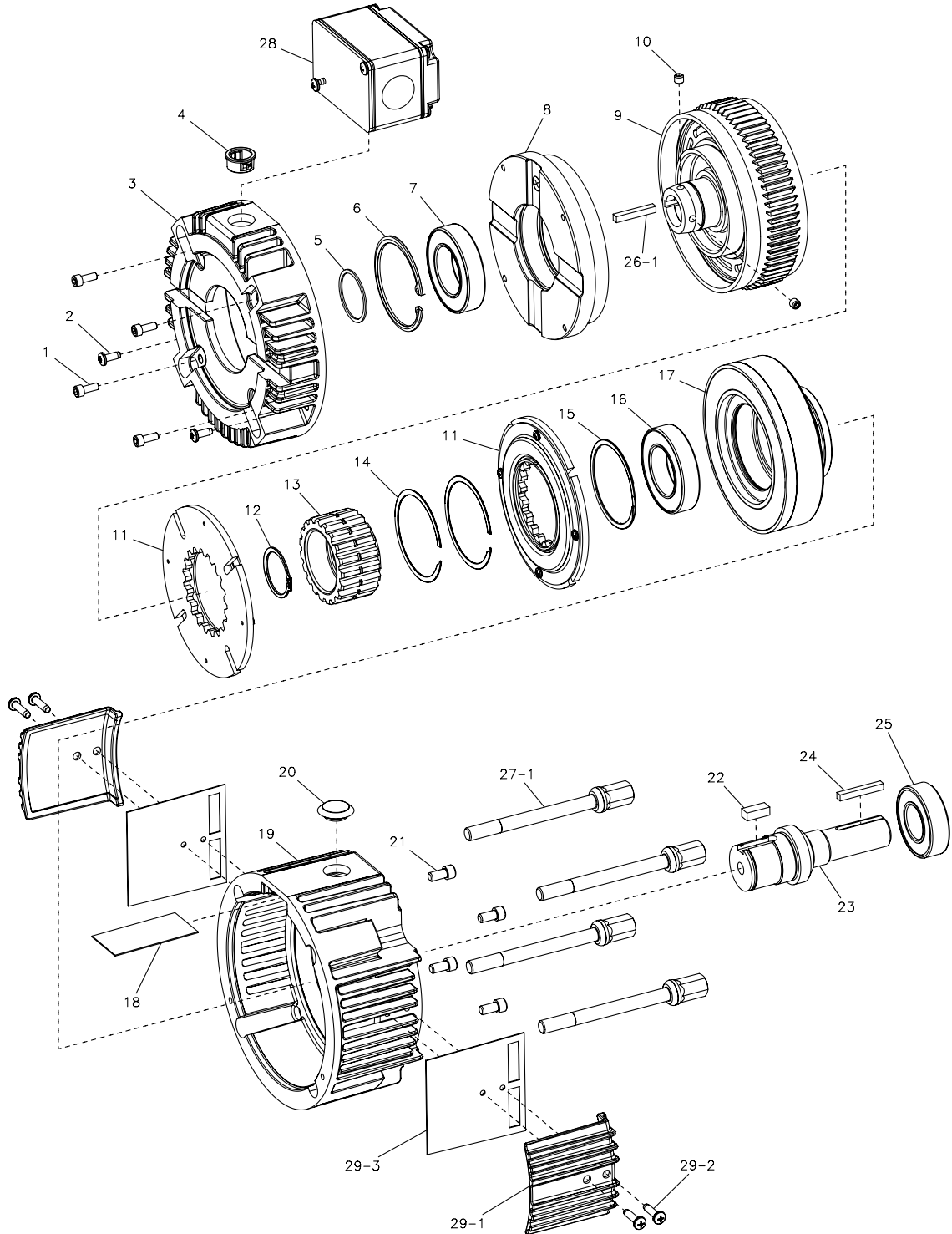

Service Parts

UM-1020 Clutch/Brake Combination Sizes 50, 100 and 180

Component Parts

Item	Description	UM-50		UM-100		UM-180	
		Part No.	Qty.	Part No.	Qty.	Part No.	Qty.
1	Field Mounting Screw	797-1214	4	797-1214	4	797-1214	4
2	Screw	797-1568	2	797-1568	2	797-1568	2
3	Housing	535-0204	1	535-0204	1	535-0204	1
4	Bushing	572-0522	1	572-0522	1	572-0522	1
5	Retaining Ring	748-0018	1	748-0018	1	748-0018	1
6	Retaining Ring	748-0561	1	748-0561	1	748-0561	1
7	Ball Bearing	166-0150	1	166-0150	1	166-0150	1
	Field Assembly		1		1		1
8	6 Volt	5370-451-201		5370-451-206		5370-451-206	
	24 Volt	5370-451-203		5370-451-208		5370-451-208	
	90 Volt	5370-451-204		5370-451-209		5370-451-209	
9	Rotor Assembly	5370-751-019	1	5370-751-049	1	5370-751-051	1
10	Set Screw	797-1098	2	797-0069	2	797-0069	2
11	Armature Assembly	5370-111-022	2	5370-111-013	2	5370-111-013	2
12	Retaining Ring	748-0445	1	748-0676	1	748-0676	1
13	Armature Hub	540-1638	1	540-2038	1	540-2038	1
14	Armature Hub Retaining Ring			748-0450	2	748-0450	2
15	Retaining Ring	748-2044	1	748-0101	1	748-0101	1
16	Ball Bearing	166-0143	1	166-0150	1	166-0150	1
	Magnet Assembly		1		1		1
17	6 Volt	5370-631-201		5370-631-216		5370-631-216	
	24 Volt	5370-631-203		5370-631-218		5370-631-218	
	90 Volt	5370-631-204		5370-631-219		5370-631-219	
18	Insulator	572-1029	1	572-1029	1	572-1029	1
19	Housing	535-0206	1	535-0206	1	535-0206	1
20	Plug	680-0037	1	680-0037	1	680-0037	1
21	Magnet Mounting Screw	797-0077	4	797-1358	4	797-1358	4
22	Key	590-0043	1	590-0084	1	590-0084	1
23	Shaft	798-0298	1	798-0301	1	798-0304	1
24	Key	590-0029	1	590-0029	1	590-0029	1
25	Ball Bearing	166-0143	1	166-0143	1	166-0143	1
26	Mounting Accessory	5370-101-072	1	5370-101-072	1	5370-101-072	1
	26-1 Key	590-0142	1	590-0142	1	590-0142	1
27	Mounting Accessory	5370-101-075	1	5370-101-075	1	5370-101-075	1
	27-1 Tie Bolt	825-0014	4	825-0014	4	825-0014	4
28	Conduit Box (Optional)	5370-101-042	1	5370-101-042	1	5370-101-042	1
	Cover Kit (Optional)	5370-101-076	1	5370-101-076	1	5370-101-076	1
29	29-1 Cover	258-1227	2	258-1227	2	258-1227	2
	29-2 Screw	797-1562	4	797-1562	4	797-1562	4
	29-3 Gasket	495-0042	2	495-0042	2	495-0042	2

Refer to service manual P-273-4-WE.
These units meet the standards of UL 508 and are listed under guide card #NMTR2, file #59164.



Service Parts

UM Series UniModule

UM-1020 Clutch/Brake Combination

Sizes 210 and 215

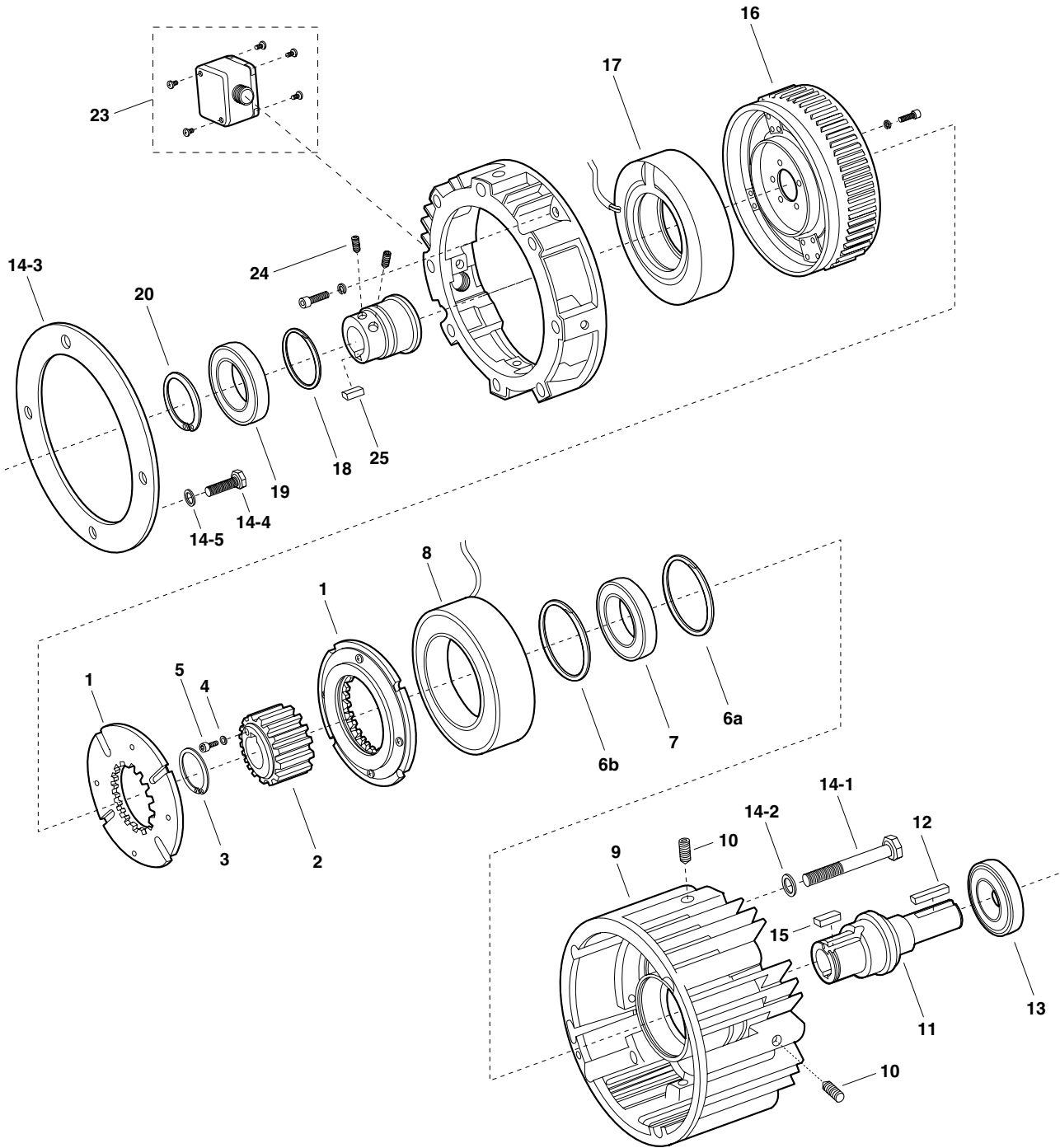

Service Parts

UM-1020 Clutch/Brake Combination Sizes 210 and 215

Component Parts

Item	Description	UM-210		UM-215	
		Part No.	Qty.	Part No.	Qty.
1	Armature Assembly	5371-111-005	2	5371-111-005	2
2	Armature Hub	540-2053	1	540-2053	1
3	Retaining Ring				
4	Lockwasher	950-0372	6	950-0372	6
5	Capscrew	797-0081	6	797-0081	6
6a	Retaining Ring	748-0112	1	748-0112	1
6b	Retaining Ring				
7	Ball Bearing	166-0142	1	166-0142	1
	Magnet		1		1
8	6 volt	5371-631-002		5371-631-002	
	24 volt	5371-631-005		5371-631-005	
	90 volt	5371-631-003		5371-631-003	
9	Housing	535-0163	1	535-0163	1
10	Setscrew	797-0103	4	797-0103	4
11	Shaft	798-0051	1	798-0254	1
12	Key	590-0019	1	590-0124	1
13	Ball Bearing	166-0144	1	166-0144	1
14	Mounting Accessory	5371-101-020	1	5371-101-020	1
	14-1 Capscrew	797-1440	4	797-1440	4
	14-2 Washer	950-0111	4	950-0111	4
	14-3 Adapter	104-0321	1	104-0321	1
	14-4 Capscrew	797-1442	4	797-1442	4
	14-5 Washer	950-0101	4	950-0101	4
15	Key				
16	Rotor Assembly (with fan and hub)	5371-751-012	1	5371-751-031	1
	Field (with housing)		1		1
17	6 volt	5371-451-027		5371-451-027	
	24 volt	5371-451-029		5371-451-029	
	90 volt	5371-451-028		5371-451-028	
18	Retaining Ring	748-0558	1	748-0558	1
19	Bearing	166-0168	1	166-0168	1
20	Retaining Ring	748-0067	1	748-0067	1
23	Conduit Box (Optional)	5370-101-042	1	5370-101-042	1
24	Set Screw	797-1098	2	797-1098	2
25	Input Key	5371-101-043	1	5371-101-044	1

Note: As of June, 2000 all rotors are manufactured as a single piece design.
The rotor assembly part number remains the same and now includes the hub and set screws.

Refer to Service Manual P-0213-WE.
These units meet the standards of UL 508 and are listed under guide card #NMTR 2, file #59164.



Service Parts

UM Series UniModule

UM-1040 Clutch/Brake Combination

Sizes 50, 100 and 180

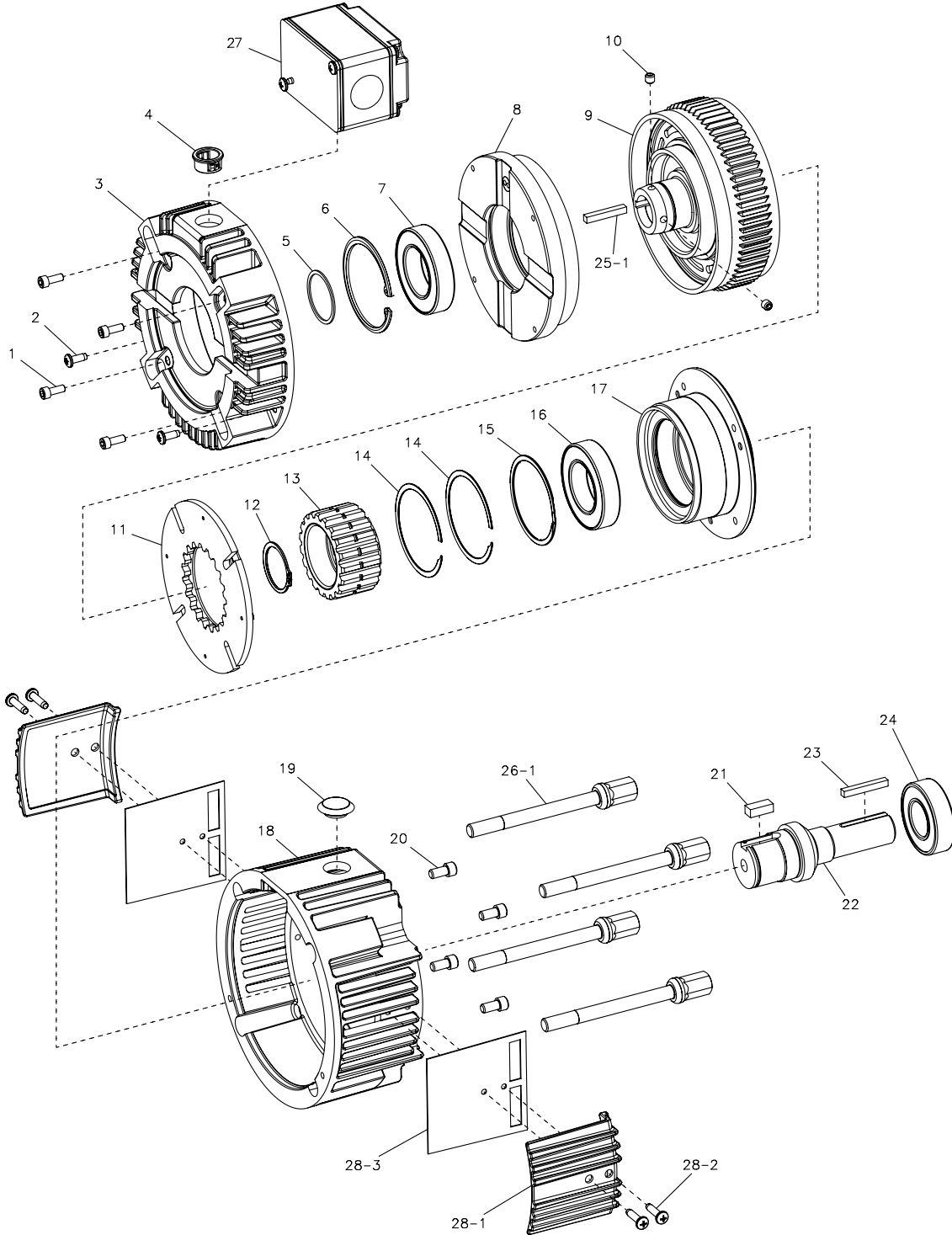

Service Parts

UM-1040 Clutch/Brake Combination Sizes 50, 100 and 180

Component Parts

Item	Description	UM-50		UM-100		UM-180	
		Part No.	Qty.	Part No.	Qty.	Part No.	Qty.
1	Field Mounting Screw	797-1214	4	797-1214	4	797-1214	4
2	Screw	797-1568	2	797-1568	2	797-1568	2
3	Housing	535-0204	1	535-0204	1	535-0204	1
4	Bushing	572-0522	1	572-0522	1	572-0522	1
5	Retaining Ring	748-0018	1	748-0018	1	748-0018	1
6	Retaining Ring	748-0561	1	748-0561	1	748-0561	1
7	Ball Bearing	166-0150	1	166-0150	1	166-0150	1
	Field Assembly		1		1		1
	6 Volt	5370-451-201		5370-451-206		5370-451-206	
8	24 Volt	5370-451-203		5370-451-208		5370-451-208	
	90 Volt	5370-451-204		5370-451-209		5370-451-209	
9	Rotor Assembly	5370-751-019	1	5370-751-049	1	5370-751-051	1
10	Set Screw	797-1098	2	797-0069	2	797-0069	2
11	Armature Assembly	5370-111-022	1	5370-111-013	1	5370-111-013	1
12	Retaining Ring	748-0445	1	748-0676	1	748-0676	1
13	Armature Hub	540-1638	1	540-2038	1	540-2038	1
14	Armature Hub Retaining Ring			748-0450	2	748-0450	2
15	Retaining Ring	748-2044	1	748-0101	1	748-0101	1
16	Ball Bearing	166-0143	1	166-0150	1	166-0150	1
17	Bearing Hub	690-0276	1	690-0278	1	690-0278	1
18	Housing	535-0207	1	535-0207	1	535-0207	1
19	Plug	680-0037	1	680-0037	1	680-0037	1
20	Hub Mounting Screw	797-0077	4	797-1358	4	797-1358	4
21	Key	590-0043	1	590-0084	1	590-0084	1
22	Shaft	798-0298	1	798-0301	1	798-0304	1
23	Key	590-0029	1	590-0029	1	590-0029	1
24	Ball Bearing	166-0143	1	166-0143	1	166-0143	1
25	Mounting Accessory	5370-101-072	1	5370-101-072	1	5370-101-072	1
	25-1 Key	590-0142	1	590-0142	1	590-0142	1
26	Mounting Accessory	5370-101-075	1	5370-101-075	1	5370-101-075	1
	26-1 Tie Bolt	825-0014	4	825-0014	4	825-0014	4
27	Conduit Box (Optional)	5370-101-042	1	5370-101-042	1	5370-101-042	1
	Cover Kit (Optional)	5370-101-076	1	5370-101-076	1	5370-101-076	1
28	28-1 Cover	258-1227	2	258-1227	2	258-1227	2
	28-2 Screw	797-1562	4	797-1562	4	797-1562	4
	28-3 Gasket	495-0042	2	495-0042	2	495-0042	2

Refer to service manual P-273-4-WE.
These units meet the standards of UL 508 and are listed under guide card #NMTR2, file #59164.



Service Parts

UM Series UniModule

UM-1040 Clutch Combination

Sizes 210 and 215

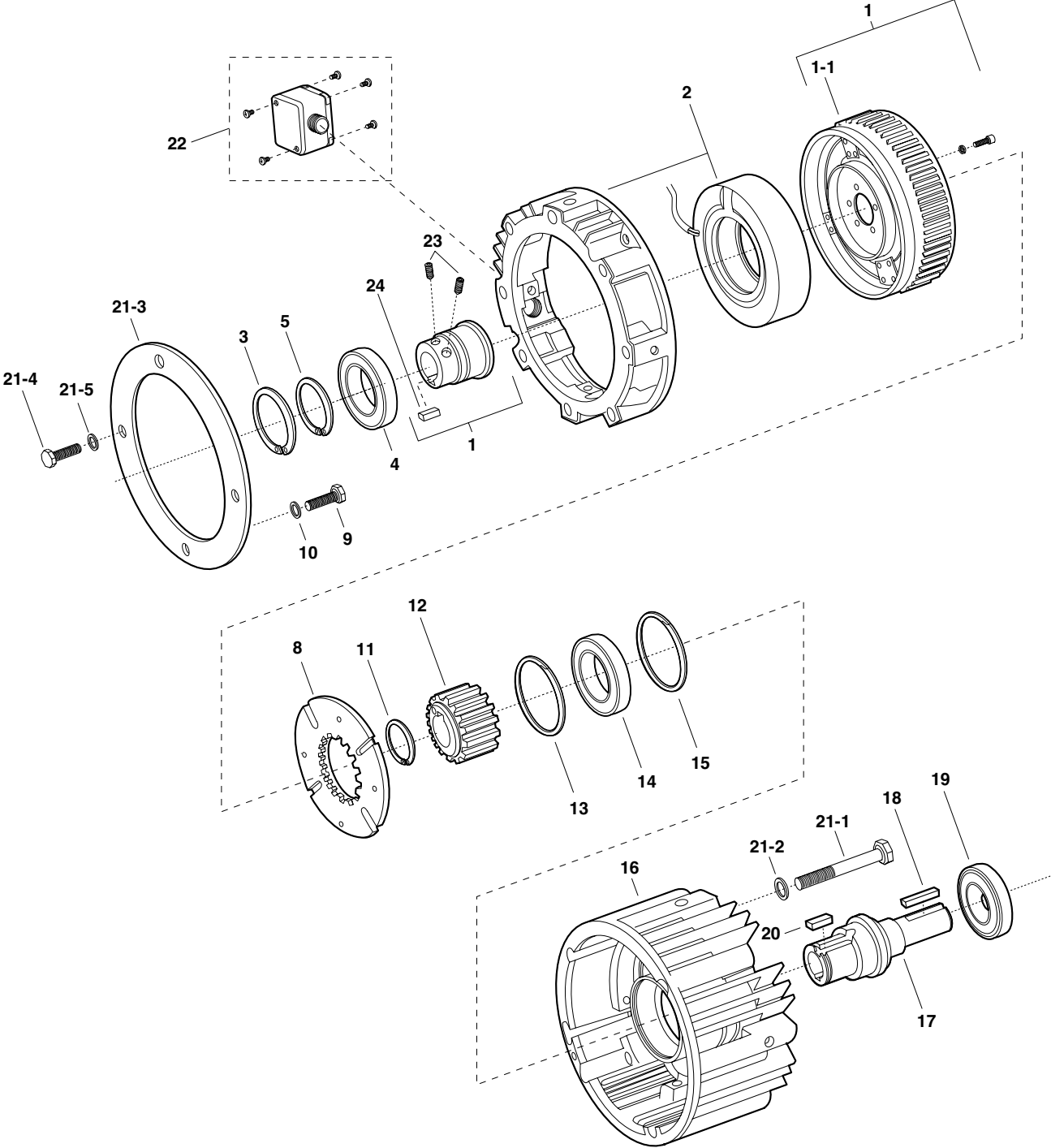

Service Parts

Component Parts

Item	Description	UM-210		UM-215	
		Part No.	Qty.	Part No.	Qty.
1	Rotor Assembly (with fan and hub)	5371-751-012	1	5371-751-031	1
	Field (with housing)		1		1
2	6 volt	5371-451-027		5371-451-027	
	24 volt	5371-451-029		5371-451-029	
	90 volt	5371-451-028		5371-451-028	
3	Retaining Ring	748-0558	1	748-0558	1
4	Bearing	166-0168	1	166-0168	1
5	Retaining Ring	748-0067	1	748-0067	1
8	Armature Assembly	5371-111-005	1	5371-111-005	1
9	Capscrew	797-0081	6	797-0081	6
10	Lockwasher	950-0372	6	950-0372	6
11	Retaining Ring				
12	Hub	540-2053	1	540-2053	1
13	Retaining Ring	748-0112	1	748-0112	1
14	Ball Bearing	166-0142	1	166-0142	1
15	Retaining Ring				
16	Housing	535-0169	1	535-0169	1
17	Shaft	798-0051	1	798-0254	1
18	Key	590-0019	1	590-0124	1
19	Ball Bearing	166-0144	1	166-0144	1
20	Key				
21	Mounting Accessory	5371-101-020	1	5371-101-020	1
	21-1 Capscrew	797-1440	4	797-1440	4
	21-2 Lockwasher	950-0111	4	950-0111	4
	21-3 Adapter	104-0321	1	104-0321	1
	21-4 Capscrew	797-1442	4	797-1442	4
	21-5 Lockwasher	950-0101	4	950-0101	4
22	Conduit Box (Optional)	5370-101-042	1	5370-101-042	1
23	Set Screw	797-1098	2	797-1098	2
24	Input Key	5371-101-043	1	5371-101-044	1

Note: As of June, 2000 all rotors are manufactured as a single piece design.
The rotor assembly part number remains the same and now includes the hub and set screws.

Refer to Service Manual P-0213-WE.
These units meet the standards of UL 508 and are listed under guide card #NMTR 2, file #59164.



UM Series UniModule

UM-2030 Clutch/Brake Combination

Sizes 50, 100 and 180

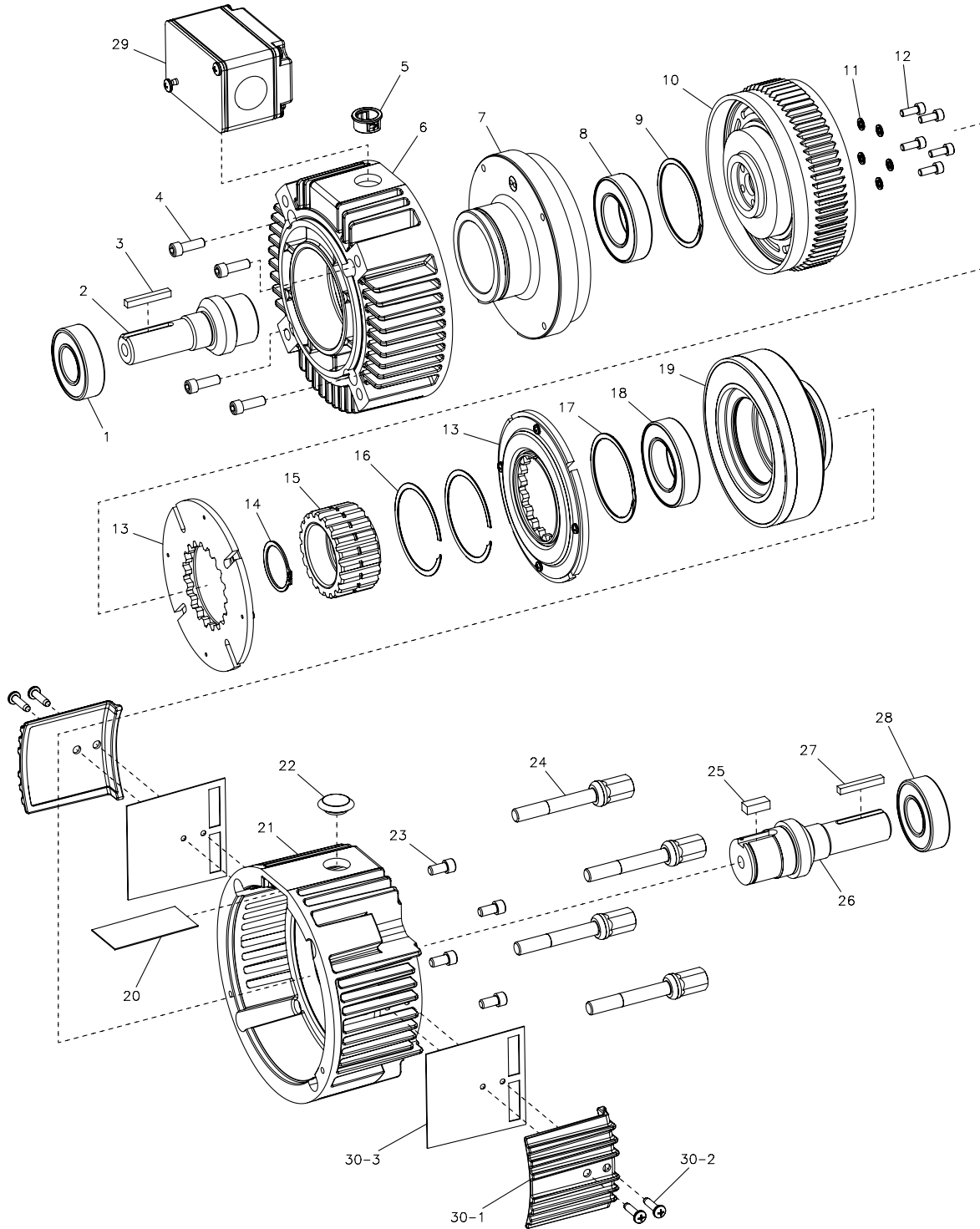

Service Parts

UM-2030 Clutch/Brake Combination Sizes 50, 100 and 180

Component Parts

Item	Description	UM-50		UM-100		UM-180	
		Part No.	Qty.	Part No.	Qty.	Part No.	Qty.
1	Ball Bearing	166-0143	1	166-0143	1	166-0143	1
2	Shaft	798-0300	1	798-0303	1	798-0306	1
3	Key	590-0029	1	590-0029	1	590-0029	1
4	Field Mounting Screw	797-0077	4	797-0077	4	797-0077	4
5	Bushing	572-0522	1	572-0522	1	572-0522	1
6	Housing	535-0205	1	535-0205	1	535-0205	1
	Field Assembly		1		1		1
	6 Volt	5370-451-211		5370-451-216		5370-451-216	
7	24 Volt	5370-451-213		5370-451-218		5370-451-218	
	90 Volt	5370-451-214		5370-451-219		5370-451-219	
8	Ball Bearing	166-0143	1	166-0150	1	166-0150	1
9	Retaining Ring	748-2044	1	748-0101	1	748-0101	1
10	Rotor Assembly	5370-751-006	1	5370-751-053	1	5370-751-053	1
11	Washer	950-0436	4	950-0436	5	950-0436	5
12	Screw	797-1294	4	797-1214	5	797-1214	5
13	Armature Assembly	5370-111-022	2	5370-111-013	2	5370-111-013	2
14	Retaining Ring	748-0445	1	748-0676	1	748-0676	1
15	Armature Hub	540-1638	1	540-2038	1	540-2038	1
16	Armature Hub Retaining Ring			748-0450	2	748-0450	2
17	Retaining Ring	748-2044	1	748-0101	1	748-0101	1
18	Ball Bearing	166-0143	1	166-0150	1	166-0150	1
	Magnet Assembly		1		1		1
	6 Volt	5370-631-201		5370-631-216		5370-631-216	
19	24 Volt	5370-631-203		5370-631-218		5370-631-218	
	90 Volt	5370-631-204		5370-631-219		5370-631-219	
20	Insulator	572-1029	1	572-1029	1	572-1029	1
21	Housing	535-0206	1	535-0206	1	535-0206	1
22	Plug	680-0037	1	680-0037	1	680-0037	1
23	Magnet Mounting Screw	797-0077	4	797-1358	4	797-1358	4
24	Tie Bolt	825-0013	4	825-0013	4	825-0013	4
25	Key	590-0043	1	590-0084	1	590-0084	1
26	Shaft	798-0298	1	798-0301	1	798-0304	1
27	Key	590-0029	1	590-0029	1	590-0029	1
28	Ball Bearing	166-0143	1	166-0143	1	166-0143	1
29	Conduit Box (Optional)	5370-101-042	1	5370-101-042	1	5370-101-042	1
	Cover Kit (Optional)	5370-101-076	1	5370-101-076	1	5370-101-076	1
30	30-1 Cover	258-1227	2	258-1227	2	258-1227	2
	30-2 Screw	797-1562	4	797-1562	4	797-1562	4
	30-3 Gasket	495-0042	2	495-0042	2	495-0042	2

Refer to service manual P-273-4-WE.
These units meet the standards of UL 508 and are listed under guide card #NMTR2, file #59164.



Service Parts

UM Series UniModule

UM-2030 Clutch/Brake Combination

Sizes 210 and 215

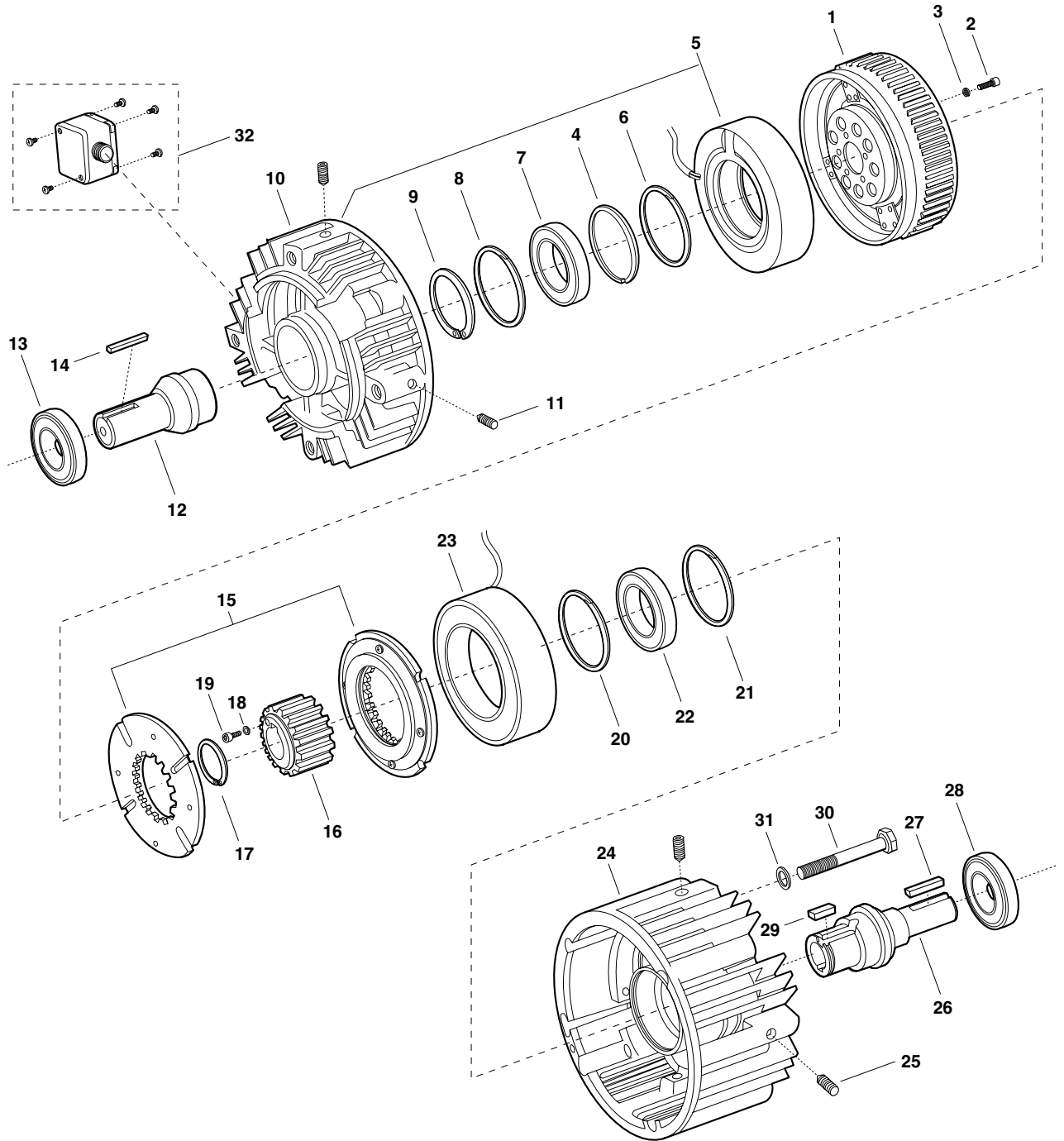

Service Parts

UM-2030 Clutch/Brake Combination Sizes 210 and 215

Component Parts

Item	Description	UM-210		UM-215	
		Part No.	Qty.	Part No.	Qty.
1	Rotor Assembly w/fan	5371-751-007	1	5371-751-007	1
2	Capscrew	797-0083	6	797-0083	6
3	Lockwasher	950-0372	6	950-0372	6
4	Spacer	807-0061	1		
	Field (with housing UM-50-2030 only)		1		1
5	6 volt	5371-451-002		5371-451-002	
	24 volt	5371-451-005		5371-451-005	
	90 volt	5371-451-003		5371-451-003	
6	Retaining Ring	748-0112	1	748-0112	1
7	Ball Bearing	166-0142	1	166-0142	1
8	Retaining Ring				
9	Retaining Ring				
10	Housing	535-0129	1	535-0129	1
11	Setscrew	797-0103	4	797-0103	4
12	Shaft	798-0123	1	798-0255	1
13	Bearing	166-0144	1	166-0144	1
14	Key	590-0019	1	590-0124	1
15	Armature Assembly	5371-111-005	2	5371-111-005	2
16	Armature Hub	540-2053	1	540-2053	1
17	Retaining Ring				
18	Lockwasher	950-0372	6	950-0372	6
19	Capscrew	797-0081	6	797-0081	6
20	Retaining Ring	748-0112	1	748-0112	1
21	Retaining Ring				
22	Ball Bearing	166-0142	1	166-0142	1
	Magnet		1		1
23	6 volt	5371-631-002		5371-631-002	
	24 volt	5371-631-005		5371-631-005	
	90 volt	5371-631-003		5371-631-003	
24	Housing	535-0163	1	535-0163	1
25	Setscrew	797-0103	4	797-0103	4
26	Shaft	798-0051	1	798-0251	1
27	Key	590-0019	1	590-0124	1
28	Ball Bearing	166-0144	1	166-0144	1
29	Key				
30	Capscrew	797-1075	4	797-1075	4
31	Lockwasher	950-0032	4	950-0032	4
32	Conduit Box (Optional)	5370-101-042	1	5370-101-042	1

Refer to Service Manual P-0213-WE.
These units meet the standards of UL 508 and are listed under guide card #NMTR2, file #59164.



Service Parts

UM Series UniModule

UM-3040 Clutch Combination-Base Mounted

Sizes 50, 100 and 180

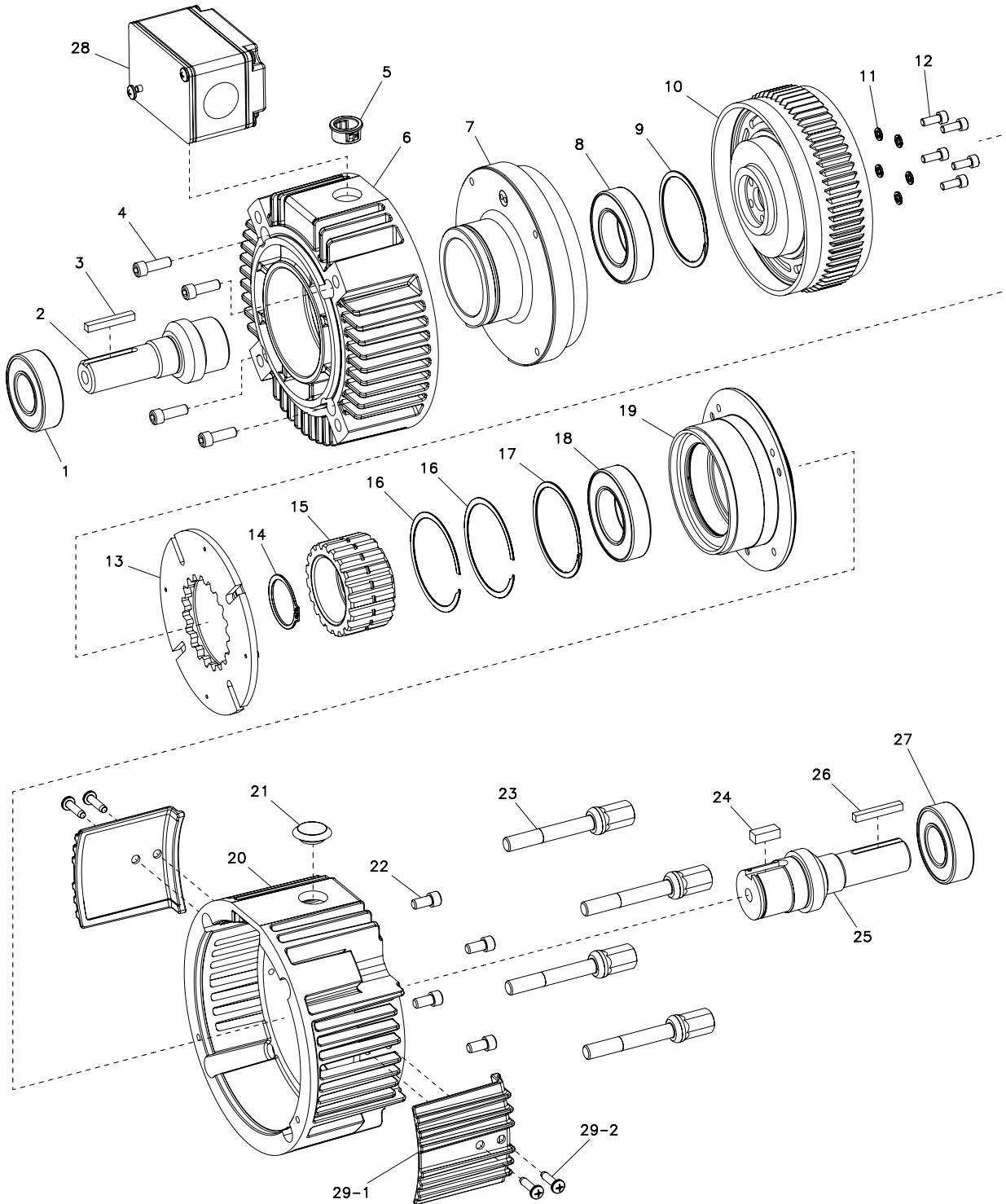

Service Parts

UM-3040 Clutch Combination-Base Mounted Sizes 50, 100 and 180

Component Parts

Item	Description	UM-50		UM-100		UM-180	
		Part No.	Qty.	Part No.	Qty.	Part No.	Qty.
1	Ball Bearing	166-0143	1	166-0143	1	166-0143	1
2	Shaft	798-0300	1	798-0303	1	798-0306	1
3	Key	590-0029	1	590-0029	1	590-0029	1
4	Field Mounting Screw	797-0077	4	797-0077	4	797-0077	4
5	Bushing	572-0522	1	572-0522	1	572-0522	1
6	Housing	535-0205	1	535-0205	1	535-0205	1
	Field Assembly		1		1		1
	6 Volt	5370-451-211		5370-451-216		5370-451-216	
7	24 Volt	5370-451-213		5370-451-218		5370-451-218	
	90 Volt	5370-451-214		5370-451-219		5370-451-219	
8	Ball Bearing	166-0143	1	166-0150	1	166-0150	1
9	Retaining Ring	748-2044	1	748-0101	1	748-0101	1
10	Rotor Assembly	5370-751-006	1	5370-751-053	1	5370-751-053	1
11	Washer	950-0436	4	950-0436	5	950-0436	5
12	Screw	797-1294	4	797-1214	5	797-1214	5
13	Armature Assembly	5370-111-022	1	5370-111-013	1	5370-111-013	1
14	Retaining Ring	748-0445	1	748-0676	1	748-0676	1
15	Armature Hub	540-1638	1	540-2038	1	540-2038	1
16	Armature Hub Retaining Ring			748-0450	2	748-0450	2
17	Retaining Ring	748-2044	1	748-0101	1	748-0101	1
18	Ball Bearing	166-0143	1	166-0150	1	166-0150	1
19	Bearing Hub	690-0276	1	690-0278	1	690-0278	1
20	Housing	535-0207	1	535-0207	1	535-0207	1
21	Plug	680-0037	1	680-0037	1	680-0037	1
22	Hub Mounting Screw	797-0077	4	797-1358	4	797-1358	4
23	Tie Bolt	825-0013	4	825-0013	4	825-0013	4
24	Key	590-0043	1	590-0084	1	590-0084	1
25	Shaft	798-0298	1	798-0301	1	798-0304	1
26	Key	590-0029	1	590-0029	1	590-0029	1
27	Ball Bearing	166-0143	1	166-0143	1	166-0143	1
28	Conduit Box (Optional)	5370-101-042	1	5370-101-042	1	5370-101-042	1
	Cover Kit (Optional)	5370-101-076	1	5370-101-076	1	5370-101-076	1
29	29-1 Cover	258-1227	2	258-1227	2	258-1227	2
	29-2 Screw	797-1562	4	797-1562	4	797-1562	4

Refer to service manual P-273-4-WE.
These units meet the standards of UL 508 and are listed under guide card #NMTR2, file #59164.



Service Parts

UM Series UniModule

UM-3040 Clutch Combination—Base Mounted

Sizes 210 and 215

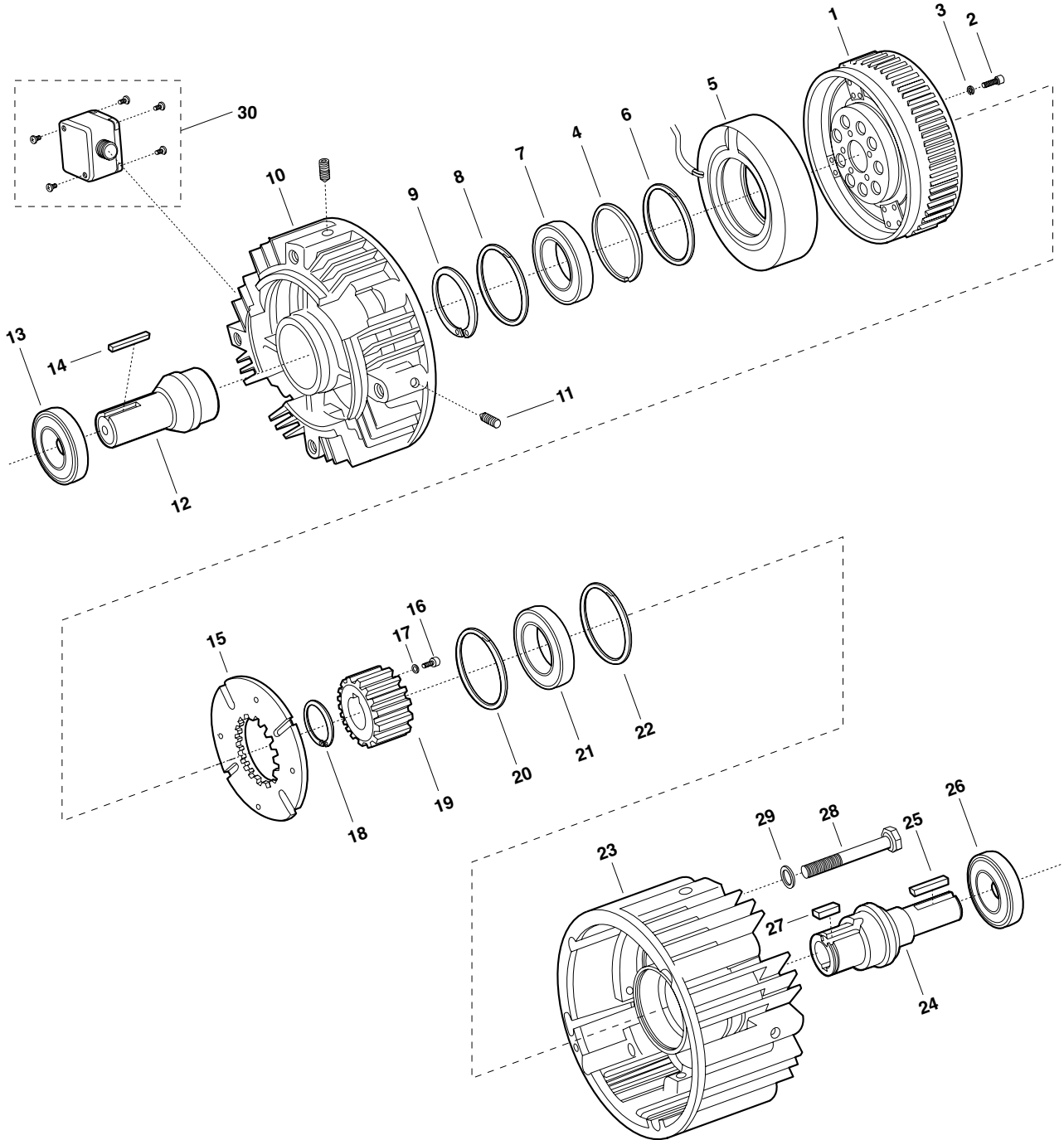

Service Parts

UM-3040 Clutch Combination–Base Mounted Sizes 210 and 215

Component Parts

Item	Description	UM-210		UM-215	
		Part No.	Qty.	Part No.	Qty.
1	Rotor Assembly w/fan	5371-751-007	1	5371-751-007	1
2	Capscrew	797-0083	6	797-0083	6
3	Lockwasher	950-0372	6	950-0372	6
4	Spacer	807-0061	1	807-0061	1
5	Field (with housing UM-50-3040 only)		1		1
	6 volt	5371-451-002		5371-451-002	
	24 volt	5371-451-005		5371-451-005	
	90 volt	5371-451-003		5371-451-003	
6	Retaining Ring	748-0112	1	748-0112	1
7	Ball Bearing	166-0142	1	166-0142	1
8	Retaining Ring				
9	Retaining Ring				
10	Housing	535-0129	1	535-0129	1
11	Setscrew	797-0471	4	797-0471	4
12	Shaft	798-0123	1	798-0255	1
13	Bearing	166-0144	1	166-0144	1
14	Key	590-0019	1	590-0124	1
15	Armature Assembly	5371-111-005	1	5371-111-005	1
16	Capscrew	797-0081	6	797-0081	6
17	Lockwasher	950-0372	6	950-0372	6
18	Retaining Ring				
19	Hub	540-0741	1	540-0741	1
20	Retaining Ring	748-0112	1	748-0112	1
21	Ball Bearing	166-0142	1	166-0142	1
22	Retaining Ring				
23	Housing	535-0169	1	535-0169	1
24	Shaft	798-0051	1	798-0251	1
25	Key	590-0019	1	590-0124	1
26	Ball Bearing	166-0144	1	166-0144	1
27	Key				
28	Capscrew	797-1075	4	797-1075	4
29	Lockwasher	950-0032	4	950-0032	4
30	Conduit Box (Optional)	5370-101-042	1	5370-101-042	1

Refer to Service Manual P-0213-WE.
These units meet the standards of UL 508 and are listed under guide card #NMTR2, file #59164.

