

ATC / ATB Series AT Clutches and Brakes

Rugged, Durable, Heavy Duty Clutches and Brakes

Warner Electric's AT clutches and brakes are rugged and durable.

The ATC and ATB incorporate a molded friction material/pole assembly and replaceable armature faces with a rugged, durable clutch and brake assembly. Uniquely designed for ease of application and low maintenance.

Besides providing the ultimate in long life and durability, the AT units are easily repairable. Mounting a standard sheave, pulley or sprocket to the clutch is a snap.

The AT Clutches and Brakes feature a replaceable friction face. The results are long life, efficient operation, and minimal down time. Service kits of pre-selected parts enhance unit life.

ATC's and ATB's are completely assembled at the factory and have been specifically designed to match the torque ratings of standard motors, reducers, and other power transmission components. Easy-to-select and easy-to-install.

AT Clutches and Brakes are ideally suited for extremely rugged, heavy duty application demands.

Advanced Technology Design Advantages

- Replaceable friction face
- Steel wear surface and cast iron hub/armature carrier
- Non-asbestos, split molded friction disc.
- Autogap™ provides automatic wear take-up for consistent engagement.
- Cast iron components—finned, cast iron armature carriers
- Special coil design for high temperature operation.
- Sealed heavy duty bearings
- Rugged spline drive operation
- Easy to install
- Maintenance free



Options and Accessories

Warner Electric offers accessories and repair kits for AT clutches and brakes, including:

- Clutch field restraining straps
- Brake torque arms
- Conduit boxes
- Clutch pulleys
- Service kits

ATC / ATB Series AT Clutches and Brakes

Applications/Mounting Configurations

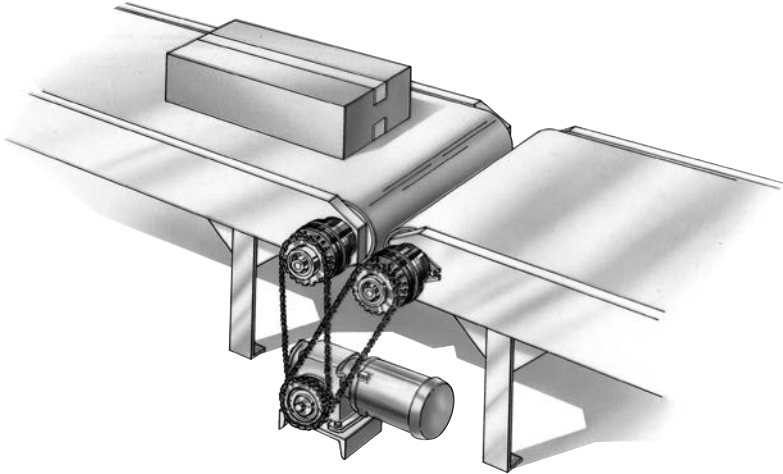

Two AT Clutches, easily mounted on conveyor headshafts, allow conveyor sections to be separately powered from a single drive.

The rugged durability of the AT Clutches and Brakes make them an obvious choice for heavy duty applications.

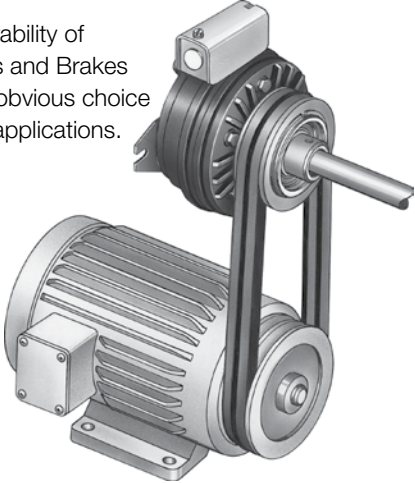

AT Clutch and AT Brake on through shaft

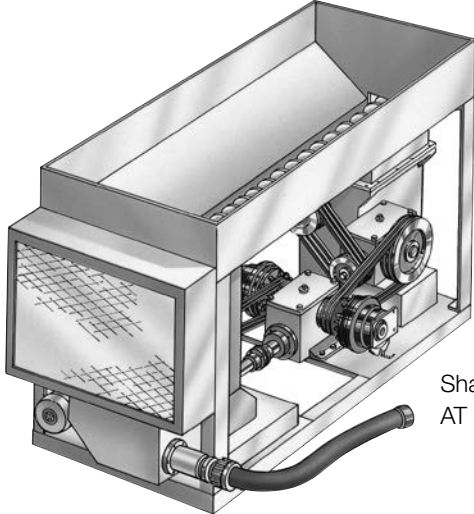
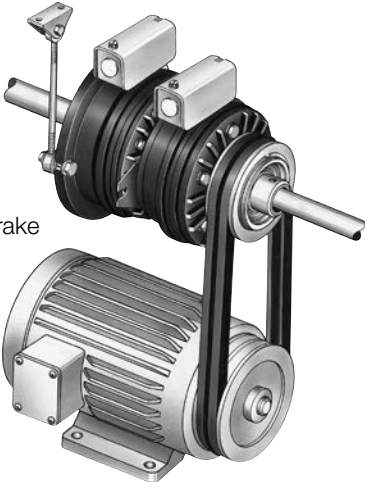

Shaft mounted AT Clutch

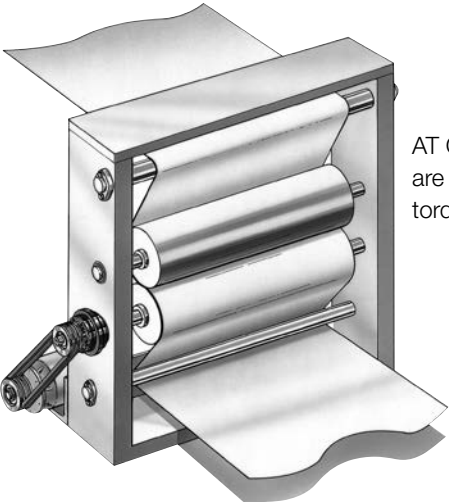

AT Clutches and Brakes are excellent for controlled torque applications.

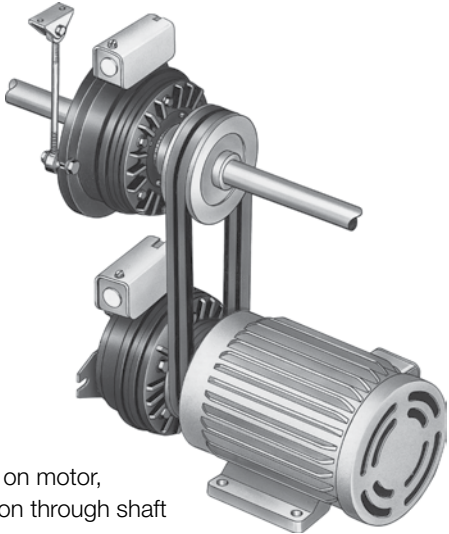

AT Clutch on motor, AT Brake on through shaft

ATC / ATB Series AT Clutches and Brakes

Performance Advantages

Principle of Operation

Ease of control is one of the most outstanding features of Warner Electric brakes and clutches. In operation, a magnetic field is generated as soon as current flows through the magnet coil. The magnetic poles are molded into a replaceable disc with the friction material. The electromagnetic force from the field or magnet passes through the poles to attract the armature, clamping the two together tightly. Strength of the magnetic field is directly proportional to the amount of current applied. The full torque range is completely controllable from 0 to 100% simply by turning the knob on the appropriate Warner Electric control.

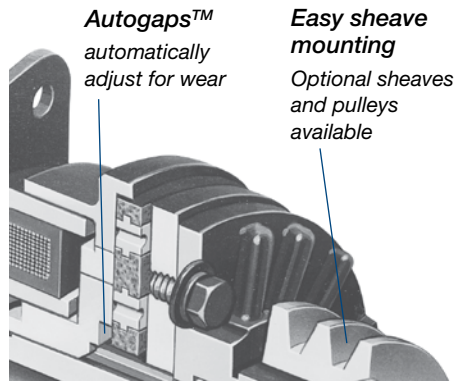

Replaceable Friction Discs

The AT Electric Clutches and Brakes feature a patented replaceable friction face incorporating a unique combination of electromagnetic poles and friction material in a simple component. Easily visible friction disc indicates when replacement

is necessary—providing a helpful maintenance guide. The results are long life, efficient operation, and minimal down time. Rebuild kits of pre-selected parts enhance unit life.

The split friction disc and armature are replaceable without unit disassembly in less than 5 minutes in most applications.

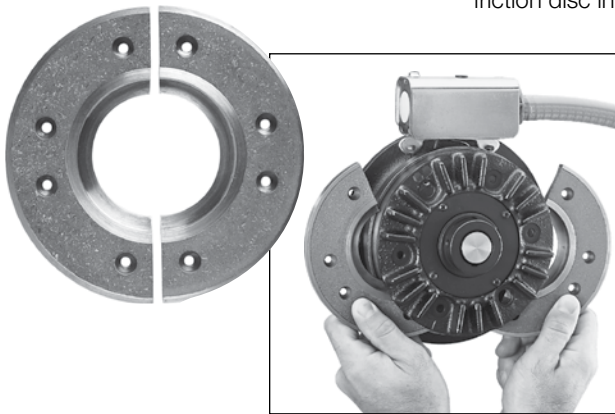

Autogap™ Alignment

Provides for automatic adjustment of the air gap between the wearing friction surfaces. Engagement times are consistent to maintain stopping and starting accuracy for the entire life of the unit.

Technical Considerations

Most normal duty applications will usually require a selection based only on horsepower and speed at the clutch or brake location as indicated on pages A-18, A-19 and A-23. However, to insure the best possible overall performance and the most cost effective unit size selection, additional factors should be considered.

The main criteria are:

1. Horsepower
2. RPM
3. System inertia at the clutch or brake
4. Cycle rate and start/stop time
5. Static torque requirement, if any.

For instance, the HP and RPM sizing derived from the selection chart on page A-19, may be different than the size required by the system inertia and cycle rate. In that case, the proper size is the larger size unit. Additional application information makes a very accurate and exacting unit size selection possible. To achieve this, system inertia and required cycle rate must be known.

Cycle Rate

Cycle rate capability is often an important selection criteria. Cycle rate is usually defined as the number of times the clutch and/or brake is switched on and off in a minute or Cycles per Minute (CPM). In order to determine the correct size unit, both required cycle rate and reflected inertia must be known. The inertia of the AT clutch/brake components has been factored into the charts, so these need not be considered. To determine size from the charts:

1. Estimate the size clutch or brake.
2. Read the chart for that size. The intersection of the reflected inertia (lb. ft.²) and speed difference (RPM) lines will indicate the maximum cycle rate for that size unit.
3. Compare cycle rates. If the cycle rate required falls within the units capability, proceed to step 4 below. If the required cycle rate is above the size selected, go to the next larger AT unit.
4. Verify selection. Compare the size selected in 2 and 3 above to the Horsepower/Speed simple selection made on page A-19. If the size selected is not the same, choose the larger selected by the two methods.

ATC / ATB Series AT Clutches and Brakes

Performance Curves

Cycle Rate Capability

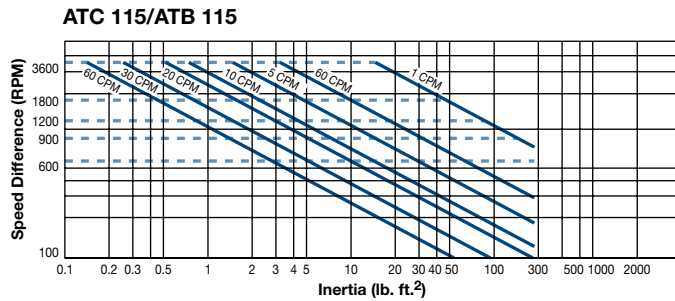
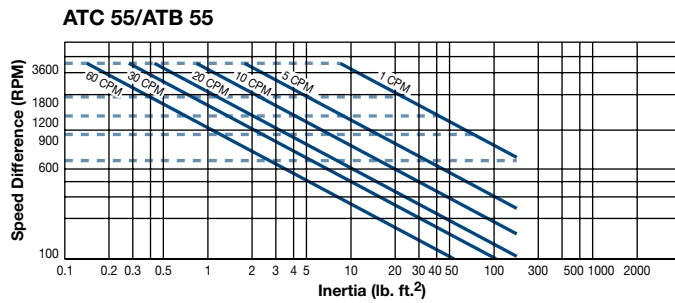
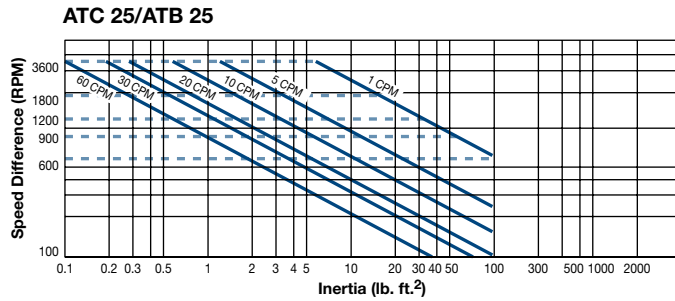

Stop/Start Time Capability

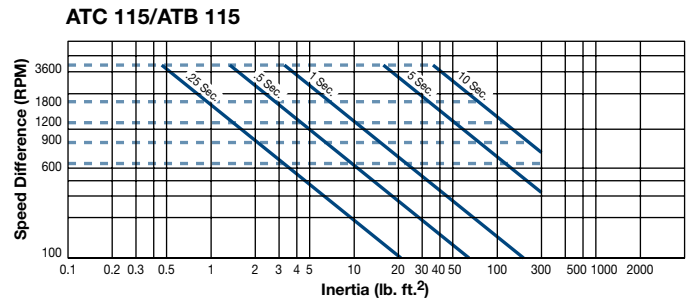
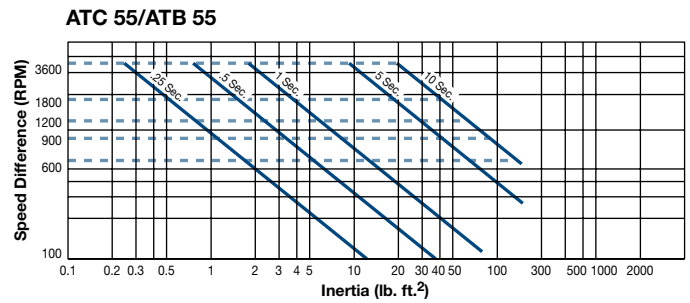
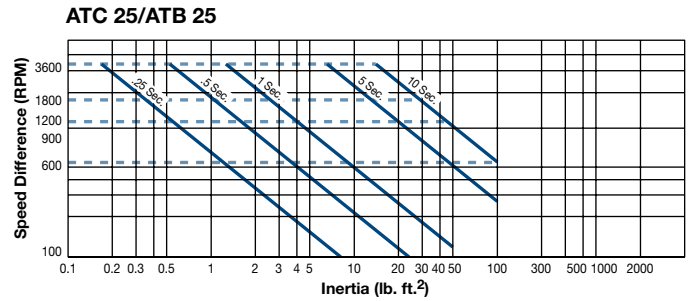

Start/Stop Times

In some applications, accelerating and/or decelerating the load within a specific time is a critical factor. In these start/stop time charts, AT unit inertias have already been factored in, so only reflected inertia need be considered. Selection for start/stop times can be made as follows:

1. Estimate the size clutch or brake required.
2. Read the chart for that size. Cross reference the speed difference (RPM) with the reflected inertia (lb. ft.²) to find the maximum start/stop capability for that size unit.
3. Compare start/stop times. If the start/stop time is equal to or less than that required for that application, the correct size unit has been selected. If shorter start/stop times are required, repeat the procedure on the chart for the next larger size unit.
4. Verify the selection. Compare the unit size chosen in steps 1, 2, and 3 to the unit size chosen by the simple Horsepower/Speed method on page A-19. If the sizes selected are not identical, choose the larger selected by the two methods.