

UM-FBC Series Electrically Released NEMA C-face Brakes

UniModule Clutch/Electrically Released Brake Combination

Warner Electric offers the convenience of pre-assembled UniModule clutch/electrically released brake packages. Assembly, alignment, and pre-burnishing have been done at the factory. Bolt it on, wire it up, and your clutch/electrically released brake is ready to go. Available in both C-face and base mounted versions.

Warner Electric's unique design employs powerful permanent magnets for maximum torque when power is removed from the brake coil. A small amount of electrical power applied to the brake coil nullifies the permanent magnets and the brake releases. No springs to limit cycle rates. Never any adjustments. No lubrication. These brakes are recommended for dynamic cycling operations only.



Sizes 50, 100 & 180

Sizes 210 & 215



1020-FBC

Motor Clutch/Electrically Released Brake

Use for clutch/power-off brake applications. Has clutch input and brake on output side. Employs powerful permanent magnets for maximum torque when power is removed from the brake coil. Basic components are field, rotor, 2 armatures and power-off magnet. See page A-19 for specifications.



2030-FBC

Input Clutch/Electrically Released Brake

Use for clutch/power-off brake applications. Has shafts on input and output sides. When electrical power is applied to the brake coil the brake releases. Ideal for dynamic cycling operations. Basic components are field, rotor, 2 armatures and power-off magnet. See page A-20 for specifications.



2030-FBC-B

Input Clutch/Electrically Released Brake with Accessory Base Mounting

See page A-20 for specifications.

UM-FBC Series Electrically Released NEMA C-face Brakes

Selection

UniModule clutch/electrically released brake units may be mounted directly to NEMA C-face motors and reducers, or can be base mounted.

1. Select Configuration

a. NEMA C-face Mounting (1020 Configuration)

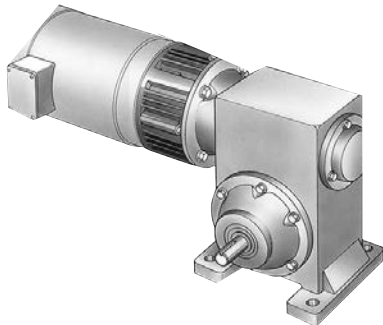

Verify the unit will be cycled frequently.

To select the correct UniModule package, determine the NEMA frame size of your motor and/or reducer, and choose the corresponding size UniModule from the Frame Size Selection chart. Verify torque ratings.

b. Base Mounting (2030 Configuration)

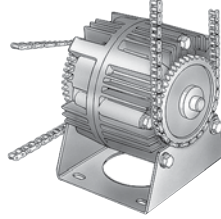

Verify the unit will be cycled frequently.

Select the correct size module from the Horsepower vs. Shaft Speed chart by determining the motor horsepower and RPM at the module location. The correct size UniModule is shown at the intersection of the HP and operating speed. For additional sizing information, refer to the technical sizing procedure (step 2).

2. Determine Technical Requirements

Technical considerations for sizing and selection are torque and heat dissipation. Each merits careful consideration, especially heat dissipation as over time, use in excessive temperature environments will have an adverse effect on bearing life and coil wire insulation integrity.

Compare the calculated torque requirement with the average dynamic torque ratings. Select a unit with adequate torque. If the unit selected on torque is different than the unit selected based on heat, select the larger size unit.

Horsepower vs. Shaft Speed

HP	SHAFT SPEED AT CLUTCH (IN RPM)																		
	100	200	300	400	500	600	700	800	900	1000	1100	1200	1500	1800	2000	2400	3000	3600	
1/4																			
1/2																			
3/4																			
1																			
1-1/2																			
2																			
3																			
5																			
7-1/2																			

*For applications with speeds below 100RPM, please contact Warner Electric Application Support.

Frame Size Selection and Technical Ratings Chart

NEMA Frame Size	UniModule Size	Static Torque Brake lb.ft.	Static Torque Clutch lb.ft.	Max. RPM	Voltage DC
56C/48Y	UM-50*	10.5	16	3600	24 or 90
	UM-100**	21	30		
182C/143TC	UM-180	21	30	3600	24 or 90
184C/145TC					
213C/182TC	UM-210	56	95	3600	24 or 90
215C/184TC					
213TC/215TC					

*For 56C/48Y C-frame motors 3/4 HP and smaller, the UM-100 size may be used where extended life is desirable.

**The UM-100 size is recommended for motors 1 HP and larger.

UM-FBC Series Electrically Released NEMA C-face Brakes

a. Heat Dissipation Sizing

Friction surfaces slip during the initial period of engagement and, as a result, heat is generated. The clutch/brake selected must have a heat dissipation rating greater than the heat generated by the application. Therefore, in high inertia or high cycle rate applications, it is necessary to check the heat dissipation carefully. Inertia, speed and cycle rate are the required parameters.

Heat dissipation requirement is calculated as follows:

$$E = 1.7 \times WR^2 \times (N/100)^2 \times F$$

where:

$$E = \text{Heat (lb. ft./min.)}$$

WR^2 = Total reflected inertia at the clutch/brake shaft. Include the clutch/brake output inertia. (lb.ft.²)

N = Speed in revolutions per minute (RPM)

F = Cycle rate in cycles per minute (CPM)

Compare the calculated heat generated in the application to the unit ratings using the heat dissipation curves. Select the appropriate unit that has adequate heat dissipation ability.

Heat Dissipation Curves

Size 50

Maximum Speed 3600 RPM

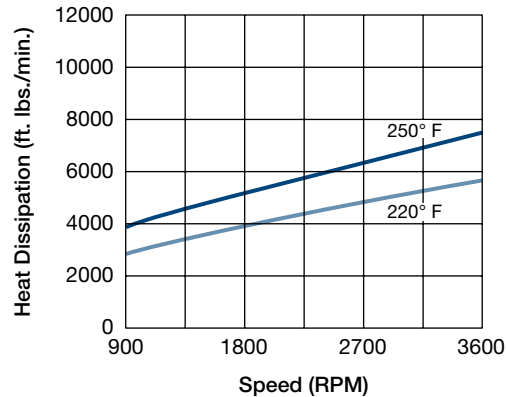

Size 100/180

Maximum Speed 3600 RPM

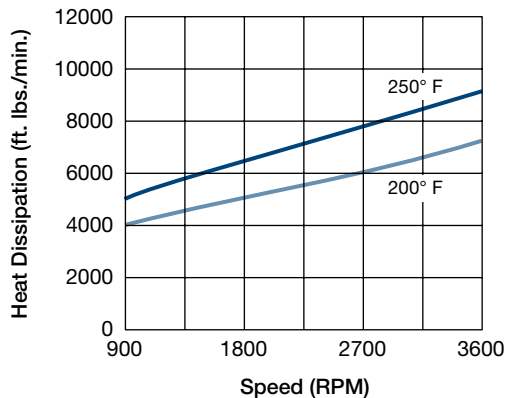

Size 210/215

Maximum Speed 3600 RPM

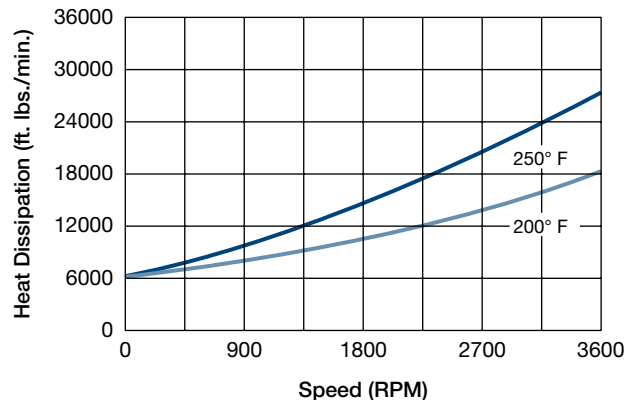

UM-FBC Series Electrically Released NEMA C-face Brakes

b. Torque Sizing

For most applications, the correct size clutch/brake can be selected from the Horsepower vs. Shaft Speed chart on page A-15. Determine the motor horsepower and the RPM at the clutch/brake. The correct size unit is shown at the intersection of horsepower and shaft speed.

If the static torque requirements are known, refer to the technical ratings chart to select a unit.

For some applications, the torque requirement is determined by the time allowed to accelerate and decelerate the load. (This time is generally specified in milliseconds.) For these applications, it is necessary to determine the torque requirement based on load inertia and the time allowed for engagement.

The torque requirements are calculated as follows:

$$T = (WR^2 \times N) / (308 \times t)$$

where:

T = Average Dynamic Torque (lb. ft.)

WR^2 = Total reflected inertia at the clutch/brake shaft. Include the clutch/brake output inertia. (lb. ft.²)

N = Speed in revolutions per minute (RPM)

t = Time allowed for the engagement (sec)

C-face Electrically Released Brake Dynamic Torque Curves

Size 50

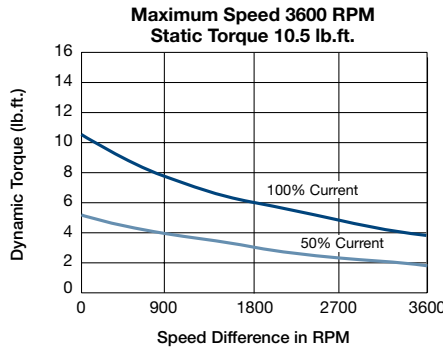

Size 100/180

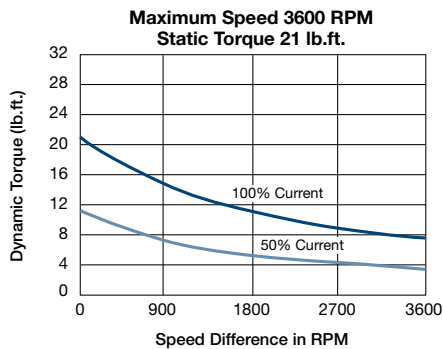

Size 210/215

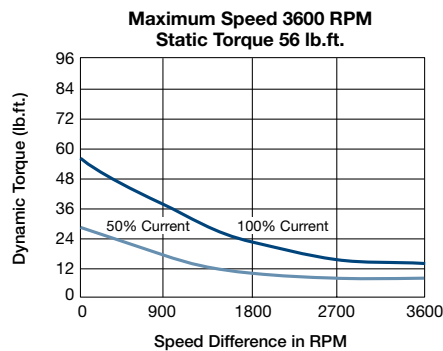

C-face Clutch Dynamic Torque Curves

Size 50

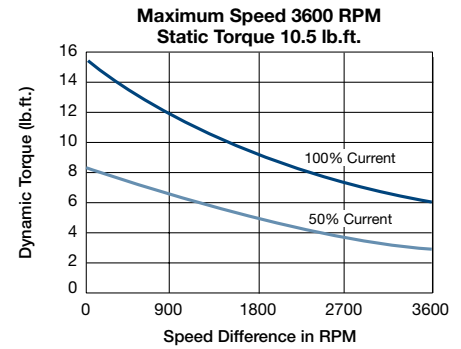

Size 100/180

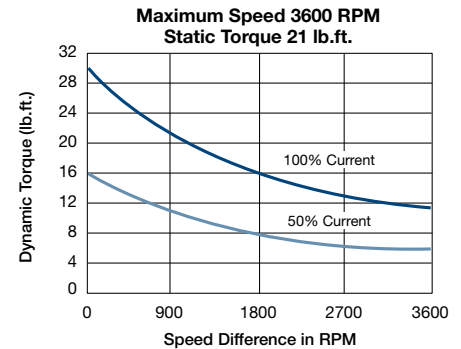

Size 210/215

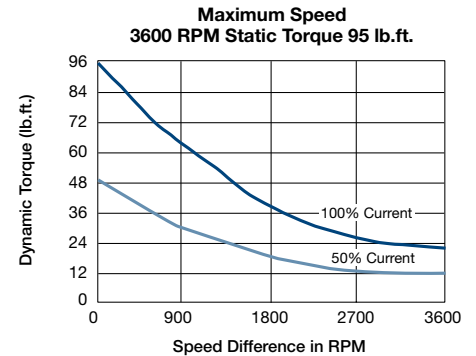

UM-FBC Series Electrically Released NEMA C-face Brakes

Ordering Information

Specifications (Max. Speed 3600 RPM)

Size	Voltage DC	Weight (lbs.)		Armature		Component Inertia-WR ² (lb. ft. ²)					NEMA Frame Size
		1020	2030	(both)	Hub	1020		2030			
						Shaft	Rotor w/Fan and Hub	Output Shaft	Input Shaft	Rotor w/Fan and Hub	
50	24	15.6	18.4	.018	.001	.001	.020	.001	.001	.020	56C/48Y
	90										
100	24	18.7	21.7	.046	.002	.002	.046	.002	.002	.046	56C/48Y
	90										
180	24	18.7	21.7	.046	.002	.002	.046	.002	.002	.046	182C/143TC
	90										
210	24	36	47	.162	.016	.014	.190	.016	.015	.183	213C/182TC
	90										
215	24	37	48	.162	.016	.016	.190	.017	.016	.183	213TC/215TC
	90										

3. Select Options

Warner Electric Enclosed UniModules can be fitted with several accessories to extend their capacity and ease of mounting.

Part Numbers

Model No.	Voltage DC	Part No.
Motor Clutch/ ER Brake		
UM-50-1020FBC	24	5370-273-243
UM-50-1020FBC	90	5370-273-244
UM-100-1020FBC	24	5370-273-248
UM-100-1020FBC	90	5370-273-249
UM-180-1020FBC	24	5370-273-253
UM-180-1020FBC	90	5370-273-254
UM-210-1020FBC	24	5371-273-013
UM-210-1020FBC	90	5371-273-012
UM-215-1020FBC	24	5371-273-099
UM-215-1020FBC	90	5371-273-079
Input Clutch/ ER Brake		
UM-50-2030FBC	24	5370-273-258
UM-50-2030FBC	90	5370-273-259
UM-100-2030FBC	24	5370-273-263
UM-100-2030FBC	90	5370-273-264
UM-180-2030FBC	24	5370-273-268
UM-180-2030FBC	90	5370-273-269
UM-210-2030FBC	24	5371-273-018
UM-210-2030FBC	90	5371-273-017
UM-215-2030FBC	24	5371-273-100
UM-215-2030FBC	90	5371-273-101

Accessories

Description	UM Size	Part No.
Conduit Box	UM series	5370-101-042
	All sizes	
Base Mount Kit for 2030 FBC	50/100	5370-101-004
	180	5370-101-002
	210/215	5371-101-019
Motor Mount Kit for 1020 FBC	50/100	5370-101-078
	180	5370-101-079
	210/215	5371-101-012
Cover Kit	50/100/180	5370-101-076

4. Select Control

All electrically released modules require a control with a potentiometer that will vary brake channel output. UM-FBC units require either a CBC-300 or a CBC 500/550 control.

How to Order

1. Specify model number and voltage or the corresponding part number.
2. Specify conduit box, if desired.
3. Specify required control unit. See the Controls Section (page CLT-1).

Ordering Example

UM-50-1020FBC, 90V or 5370-273-244; 5370-101-042 conduit box; CBC-300 control.

UM-FBC Series Electrically Released NEMA C-face Brakes

UM-1020 FBC Motor Clutch/Electrically Released Brake

SIZE 50/100/180

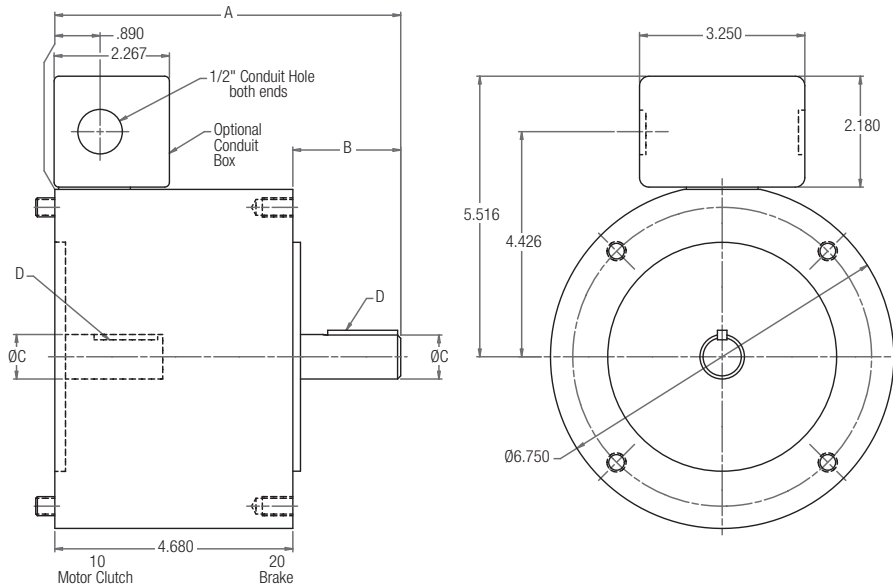

SIZE 210/215

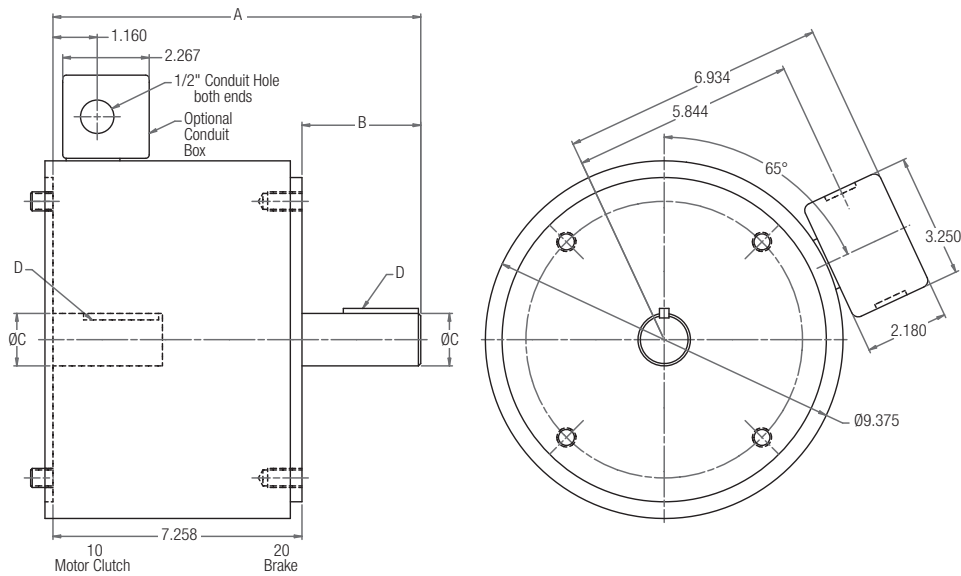

Dimensions

Size	A	B	C	D
50	6.720	2.040	0.625	3/16 x 3/16
100	6.741	2.061	0.625	3/16 x 3/16
180	6.801	2.121	0.875	3/16 x 3/16
210	9.872	2.614	1.125	1/4 x 1/4
215	10.372	3.114	1.375	5/16 x 5/16

For standard NEMA frame dimensions, see page G-3.

Motor Mount (M) Dimensions

For use with 1020 FBC Combination.

Size	R	S	T	U	V	W	Part No.
50/100	9.250	8.250	10.500	8.000	3.500	.800 x .406	5370-101-078
180	9.250	8.250	10.500	8.000	4.500	.800 x .406	5370-101-079
210/215	11.500	10.500	12.000	9.000	5.250	.750 x .409	5371-101-012

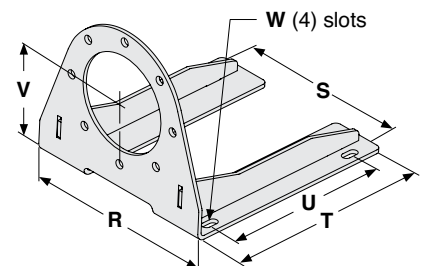

UM-FBC Series Electrically Released NEMA C-face Brakes

UM-2030 FBC Input Clutch/Electrically Released Brake

UM-2030 FBC-B Input Clutch/Electrically Released Brake – Base Mounted

SIZE 50/100/180

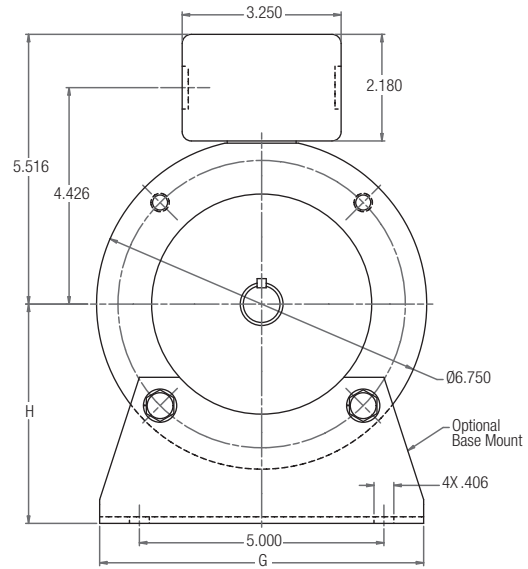
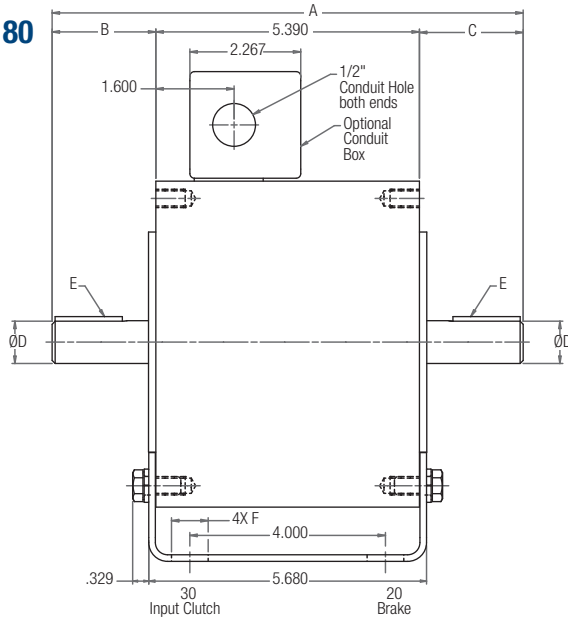

Note: Mounting base and conduit box are optional and are ordered separately.

SIZE 210/215

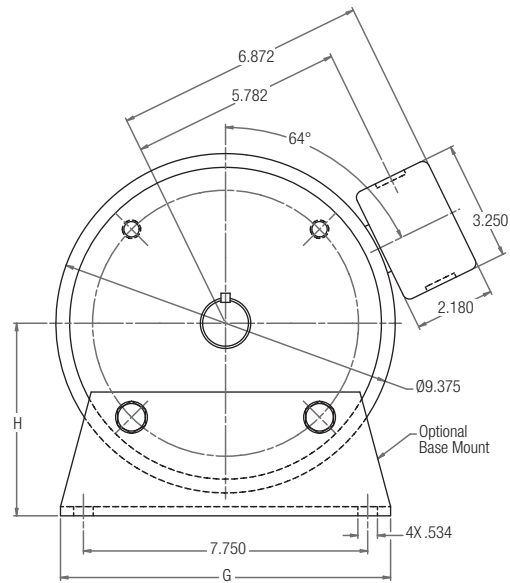
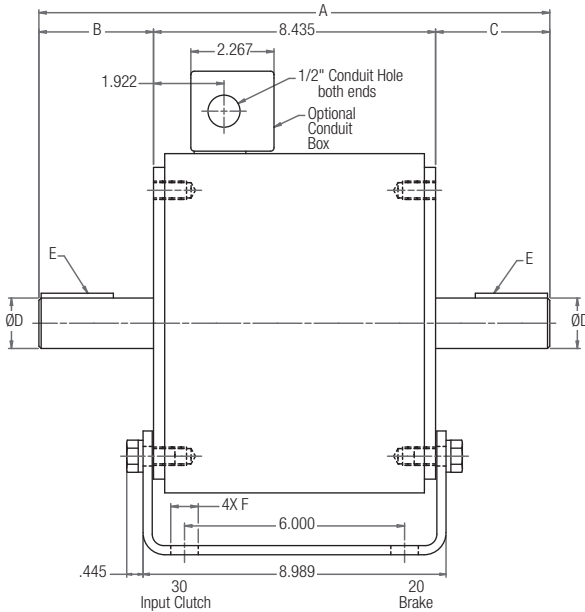

Dimensions

Size	A	B	C	D	E	F	G	H
50	9.492	2.062	2.040	0.625	3/16 x 3/16	0.800	6.000	3.500
100	9.512	2.061	2.061	0.625	3/16 x 3/16	0.800	6.000	3.500
180	9.632	2.121	2.121	0.875	3/16 x 3/16	0.750	6.625	4.500
210	13.674	2.625	2.614	1.125	1/4 x 1/4	0.750	9.000	5.250
215	14.674	3.125	3.114	1.375	5/16 x 5/16	0.750	9.000	5.250

For standard NEMA frame dimensions, see page G-3.

UM-FBC Series Electrically Released NEMA C-face Brakes

Enclosing UM-FBC Series

Clean, quiet, operation. Nothing can get in, nothing can get out. Enclosed design eliminates damage to the working components. Prevents friction wear particles from escaping.

Totally Enclosed Version

The Enclosed UniModule packages the hardworking components from UM products into a totally enclosed housing. This rugged housing keeps wear particles in and contaminants out and provides quiet operation. Pre-burnished at the factory for rated torque directly out-of-box. When enclosed, they are suitable for most industrial applications and tolerate infrequent, light washing.

- Keeps contaminants out
- Keeps wear particles in
- Quiet operation
- Finned for heat dissipation
- UL listed when optional conduit box is installed

Heat Dissipation Curves

UM-50 with Cover Kit

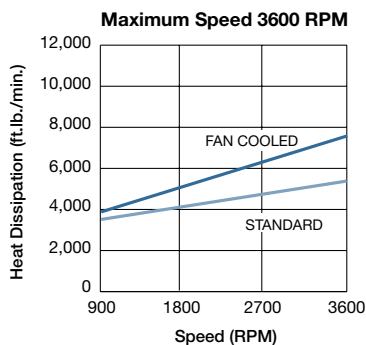

UM-100/180 with Cover Kit

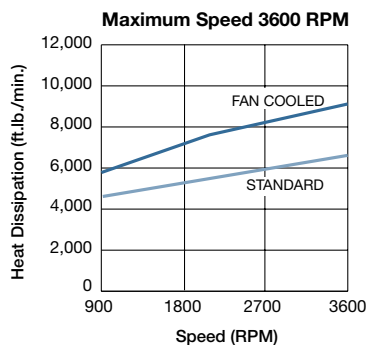

To convert any UM Series UniModule 50, 100, and 180 sizes to an enclosed model, purchase optional Cover Kit

Enclosed UniModule Conversion

Part Number 5370-101-076

An optional cover kit can be purchased separately to enclose the open vents in the housing. Each kit contains (2) vent covers, (2) gaskets and (4) screws. A vent cover bolts to both sides of the UniModule unit to enclose the open vents of the housing creating a totally enclosed (non-washdown) brake package which keeps contaminants out and wear particles in for clean, quiet operation.

