







# Permanent Magnet Electrically Released Brakes



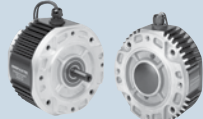

# Permanent Magnet Electrically Released Brakes

<b>Pages</b>	<b>Permanent Magnet Electrically Released Brakes</b>		
1-6	<b>Product Line Overview Introduction to Packaged Performance Products</b>		
A-2	<b>Electronically Released Brakes Selection Guide</b>		
A-4	<b>Shaft Mounted Permanent Magnet Brakes</b> (FB Series)		
A-8	<b>Flange Mounted Permanent Magnet Brakes</b> (ER Series)		
A-12	<b>Permanent Magnet NEMA C-face Clutch/Brake Modules</b> (UM-FBC Series)	<b>SIZES 50, 100, 180</b>	<b>SIZES 210, 215</b>
			
A-21	<b>Enclosed Permanent Magnet NEMA C-face UniModules</b> (EUM-FBB & EUM-MBFB Series)		
A-29	<b>Permanent Magnet NEMA C-face Brake Modules</b> (EM-FBB, EM-FBC & EM-MBFB Series)		
SP-1	<b>Permanent Magnet Compatible Service Parts</b>		
G-1	<b>General Engineering Data</b>		
G-3	NEMA Standard Ordering Info		
G-4	Mechanical		
G-8	Electrical Data		
AD-1	<b>Application Data Form</b>		
CTL-1	<b>Clutch/Brake Controls</b>		
PN-1	<b>Part Numbers</b>		
I-1	<b>Index</b>		



# Packaged Performance Products

---

## Electromagnetic Clutches and Brakes

### Packaged Products Benefits

Warner Electric Packaged Products come pre-assembled, ready to install right out of the box.

Warner Electric Packaged Products consist of a single part number in most cases. One part number to inventory, one part number to track in your engineering system.

All Warner Electric packaged products incorporate our Autogap™ mechanism that automatically adjusts for wear. This eliminates the need for maintenance, but more importantly, it ensures the same engagement time cycle after cycle after cycle through the whole life of the unit ensuring consistent product manufacturing processes.

Warner Electric Packaged designs are available for:

- C-face mount applications
- Parallel shaft applications
- Base mount applications

### The Basics

The electric clutch and brake has been called the best thing that ever happened to the electric motor. It's simple, electric clutches and brakes do all the work, while permitting motors to run smoothly and continuously at their most efficient speed by connecting/disconnecting the motor and the load. Fast starts and stops, easy control interface, remote pushbutton operation and smooth acceleration and deceleration are outstanding user benefits.

### Reliable Performance

- High cycle rates
- Smooth soft starts
- Cushioned stops
- Accurate positioning
- Indexing
- Jogging
- Reversing
- Speed changing



# Packaged Performance Products

## Electromagnetic Clutches and Brakes

### Principle of Operation

A key feature of Warner Electric brakes and clutches is the method of actuation. Like an electromagnet, they have two basic parts. A magnetic field is generated as soon as the current flows through the magnet coil. This draws the armature into direct contact with the magnet. The strength of the magnetic field is directly proportional to the amount of current applied. Full range torque control from 0 to 100% is as simple as turning the knob on a light dimmer.

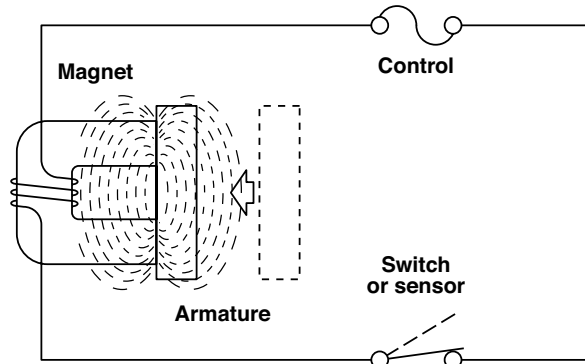

### Fast and Accurate

The benefits of electric actuation combined with the use of small, low inertia components is fast response, high cycle rates, and increased accuracy. While other devices are often sluggish and slow to respond, electric brakes and clutches respond instantly, resulting in higher productivity and better consistency.

### Controllable

Electric brakes and clutches are incredibly easy to control. The shift from positive, instantaneous engagement to soft, cushioned starts and stops is as simple as turning a knob.



### Easy to Select

Most of the time, all you need to know is motor horsepower and the speed at the brake or clutch location. Warner Electric takes care of the rest. The performance you require is built in, and with the broad range of products to choose from, you won't have to compromise with a clutch or brake that's a little too big or a little too small.

### Torque/Current Curve

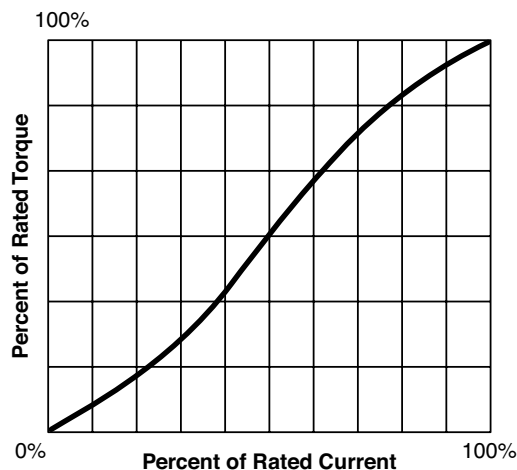

### Maintenance Free

Warner Electric brakes and clutches are clean and quiet. They require no maintenance. They never need lubrication, and they're completely self adjusting for wear. No complicated air system or messy hydraulics. Warner Electric brakes and clutches are outstandingly trouble free.

# Packaged Performance Products

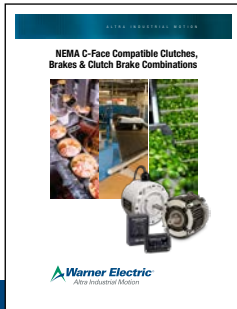

## NEMA C-face Clutches, Brakes and Clutch Brake Combinations P-8586-WE

### Electro Module

#### Individual Clutch and Brake Modules



#### EM Series

##### Modular Components that are Easily Combined

- ❑ 5 sizes
- ❑ 16 clutch and brake modules
- ❑ 16 to 95 lb. ft. torque range

Individual modules may be used in combination to form clutches, brakes or clutch/brake packages.

Electro Modules can be bolted directly to NEMA C-face motors or reducers, or base mounted for stand alone operation.

See P-8586-WE for Service Parts

### UniModule®

#### One Piece Preassembled Clutches and Clutch/Brakes



#### UM Series

##### C-face or Base Mounted Units

- ❑ 5 sizes
- ❑ 20 combinations
- ❑ 16 to 95 lb. ft. torque range

UniModule clutches and clutch/brake packages offer the ultimate in installation convenience.

Can be motor or reducer mounted, or used as a separate drive unit powered from a prime mover.

See P-8586-WE for Service Parts

#### UM Smooth-Start

##### Soft Engage Designs

- ❑ 5 sizes
- ❑ 10-57 lb.ft. torque range

Smooth-Start designs allow for a soft engage clutch and brake without sacrificing unit life.

#### UM-C Series

##### High Performance Version for High Cycle Rate Applications

- ❑ 3 sizes
- ❑ 6 combinations
- ❑ 16 to 95 lb. ft torque range

The UM-C units are UniModules with ceramic faced components, specifically designed for long life, high energy, and high cycle rate applications.

### Enclosed UniModule®

#### Preassembled Units Offer Clean, Quiet Operation



#### EUM Series

##### Totally Enclosed Clutch and Brake Packages

- ❑ 5 sizes
- ❑ 3 combinations
- ❑ 16 to 95 lb. ft. torque range

Totally enclosed, rugged enclosure keeps wear particles in and contaminants out. Finned for rapid heat dissipation and long life.

See P-8586-WE for Service Parts

#### EUM-W Series

##### Washdown Version

- ❑ 5 sizes
- ❑ 8 combinations
- ❑ 16 to 95 lb. ft. torque range

The washdown version of the EUM uses stainless steel shafting, USDA approved coating, corrosion resistant fasteners and special seals.

See P-8586-WE for Service Parts

# Packaged Performance Products



## Shaft Mounted Clutches & Brakes P-8587-WE

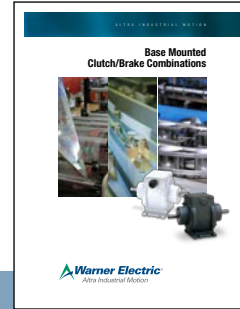

## Base Mounted Clutch/Brake Combinations P-8588-WE

### Electro Clutches Electro Brakes

#### Shaft Mounted Units



#### EC Series Clutches

##### Pre-Packaged Convenience

- ❑ 6 sizes
- ❑ 16 to 465 lb. ft. torque range

All the features of an electric clutch in a convenient, pre-packaged assembly. Mounts on any through shaft or extended motor shaft. Easy-to-assemble with standard sheaves, pulleys, gears and sprockets. Packaged design. No assembly required. Long life. No maintenance.

See P-8587-WE for Service Parts

#### EB Series Brakes

##### Torque Arm Mounting

- ❑ 6 sizes
- ❑ 16 to 465 lb. ft. torque range

Torque arm feature makes Electro Brakes easy to mount on any motor or through shaft. Packaged design. No assembly required. Long life. No maintenance.

See P-8587-WE for Service Parts

### Advanced Technology Clutches and Brakes

#### Extra Rugged Design



#### ATC Series Clutches ATB Series Brakes

##### Replaceable Friction Faces

- ❑ 3 sizes
- ❑ 25 to 115 lb. ft. torque range

Rugged, heavy duty units designed for extra long life and efficient operation. Cast components for durability. Finned armatures for high heat dissipation.

Friction faces are designed to allow for replacement without replacing valuable, non-wear components. Provides superior wear life with reduced engagement noise.

See P-8587-WE for Service Parts

#### SFP Series Clutches

- ❑ Pre-assembled SF – No assembly required
- ❑ Ball bearing mounted field and armature
- ❑ 70 inch pound and 270 inch pound sizes
- ❑ Bore sizes from 3/8" to 1/2" and 1/2" to 1"

SFP clutches provide the simplicity and cost efficiency of the Basic SF design, but with a ball bearing mounted armature hub.

### Electro Pack Clutch/Brakes

#### Foot Mounted Units

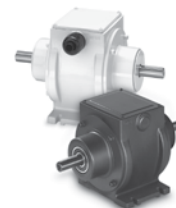

#### EP Series

##### Totally Enclosed Units

- ❑ 8 sizes
- ❑ 15 lb. to 1350 lb. ft. torque range

Electro Packs are rugged, pre-assembled clutch and brake combinations in enclosed, foot mounted housings.

See P-8588-WE for Service Parts

#### EP-C Series

##### High Performance Version

- ❑ 2 sizes
- ❑ 15 and 70 lb. in. torque

Ceramic faced wear components provide long life for high cycle rate use. Consistent torque and cycle repeatability with Smooth-Start/stop control.

#### EP-W Series

##### Washdown Design

- ❑ 2 sizes
- ❑ 70 and 270 lb. in. static torque ranges
- ❑ USDA approved coating
- ❑ Stainless steel shaft and hardware
- ❑ Available in 24 or 90 volt DC

# Packaged Performance Products

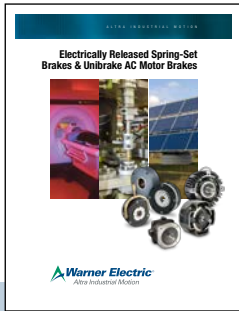

## Electrically Released Spring-Set Brakes & Unibrake AC Motor Brakes P-8589-WE

### Spring-Set Brakes

For Power-Off Static Holding and Emergency Stopping Applications

**WARNING** For general use in horizontal shaft applications only. For possible vertical applications, contact technical support.



#### ERS Series

Static Engaged

- 5 sizes
- 1.5 to 100 lb. ft. holding torque

Designed for static holding. ERS models feature multiple coil springs that force armature and friction faces together to generate braking torque when power is off. The Electromagnet counters the spring force to disengage the brake when power is applied.

Although this brake should be engaged only when the shaft is at rest, it can occasionally act as a dynamic braking device to stop a rotating load in an emergency situation.

#### Spring Set Brake Module

- 7 to 100 lb. ft. holding torque
- NEMA C-face version of the ERS Series



#### ERD Series

Dynamic Braking

- 8 sizes
- 4 to 221 lb. ft. holding torque

ERD units are electrically released, static and dynamic engaged, spring-set brakes for power-off load holding applications. These spring-set brakes automatically stop and hold a load in the event of a power failure or other emergency stop situations. Fully dynamic friction material allows for repeated braking cycles from full motor speed with no torque fade. An optional manual release allows the brake to be released by hand.

#### Unibrake Series AC Motor Brakes

- Spring Set/Solenoid Released
- Direct acting/manual release standard 3 families
- 3, 6, 10 and 15 lb. ft. capacity
- Steel or cast iron covers
- Rear mount or double C-face designs

### Permanent Magnet Brakes

For Power-Off Dynamic Stopping and Cycling Applications



#### FB Series

Shaft Mounted, Dynamic Braking

- 3 models
- 10.5 to 56 lb. ft. static torque

Permanent magnet brakes are designed to dynamically stop and hold a moving load and also for high cycle rate stopping. Electric power to the coil nullifies the attraction of the permanent magnet, releasing the brake.

FB models are pre-assembled and feature a torque arm for convenient shaft mounting.

See P-8590-WE for Service Parts.

#### ER Series

Flange Mounted, Dynamic Braking

- 5 models
- 10.5 to 400 lb. ft. static torque

The ER style brake offers a bulk head flange mounting system, the highest torque rating offered by Warner Electric in the power released series, high cycle rate capability, and excellent life. They require some assembly.

See P-8590-WE for Service Parts.



## Permanent Magnet Electrically Released Brakes P-8590-WE

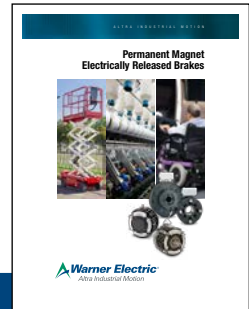

### Electro Module

#### C-face Brake Modules



#### EM-FBC Clutch/Brakes

##### Individual Module Components

- ❑ 3 sizes
- ❑ 10.5 to 56 lb. ft. torque range

Used in combination with an Electro Module motor or input clutch module for clutch/brake applications. Electrical power applied to the brake coil nullifies the permanent magnets' force and the brake releases. No springs to limit cycle rates.

#### EM-FBB

##### Brake Modules

- ❑ 5 sizes
- ❑ 10.5 to 56 lb. ft. torque range

Use for brake alone applications. Mounts between a C-face motor and reducer. Recommended for dynamic cycling operations only.

#### EM-MBFB

##### Motor Brakes

- ❑ 4 sizes
- ❑ 56C to 215C frame motors

Mounts to the back of a double shafted C-face motor. Never needs adjustment or lubrication.

### UniModule

#### C-face Brake Modules



#### UM-FBC Clutch/Brakes

##### One Piece Packages

- ❑ 4 sizes
- ❑ 7 combinations
- ❑ 10.5 to 56 lb. ft. static brake torque

UniModule pre-assembled clutch and electrically released brake packages are available in both C-face and base mounted versions.

Unique design employs powerful permanent magnets for maximum torque when power is removed from the brake coil. A small amount of electrical power applied to the brake coil nullifies the permanent magnets and the brake releases. No springs to limit cycle rates. Never any adjustment. No lubrication. These brakes are recommended for dynamic cycling operations only.

### Enclosed UniModule

#### C-face Brake Modules



#### EUM-FBB Brake Modules

##### Totally Enclosed

- ❑ 4 sizes
- ❑ 6 to 32 lb. ft. static torque

Totally enclosed UniModule electrically released brake packages keep contaminants out and wear particles in for clean, quiet operation. Assembly, alignment, and preburnishing have been done at the factory. Use for brake alone applications, mountings between a motor and a gear reducer. Select the torque required for the application. Higher torque brakes stop loads faster. Lower torque models provide softer stopping to prevent boxes on conveyors from tipping or skidding.

#### EUM-MBFB

##### Motor Brakes

- ❑ 4 sizes
- ❑ 56C to 215C frame motors

UniModule motor brakes are used for dynamic stopping and holding of loads when power is removed from the motor. Typical applications include conveyors, process equipment, and lifting devices. Mounts to a double shafted C-face motor.



---

# **Permanent Magnet Brakes**

# **Permanent Magnet NEMA C-Face Brakes**



**A**

# Selection Guide Electrically Released Brakes

Electrically Released brakes fall within two categories: **Static Engage** and **Dynamic Stopping**. Static engage brakes are similar in function to an automotive parking brake: while they can be used to stop in an emergency, they are primarily to hold a load stationary after the load is already stopped. A static engage brake that is used as an active stopping brake at high cycle rate will wear out quickly.

Common industrial static applications are vertical or incline conveyors. The drive and motor may decelerate the conveyor to a stop and then engage the brake to hold the load in position. A second common application is where a servo or step motor will accelerate and decelerate the load and the brake holds the load in proper position.

Dynamic engage brakes are those designed to actively stop and hold the load. In these applications the brake is the force that stops the load as well as hold it. Dynamic engagement brakes are designed to provide appropriate life in applications where they experience frequent cycles per minute.









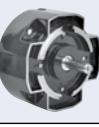

All electrically released brakes will engage when power is turned off and as such will provide emergency stop braking.

## Static Engage Brakes

- ERS
- ERD
- EM/ERS

## Dynamic Engage Brakes

- FB
- ER
- EM-FBB, FBC, MBFB
- UM-FBC and MBFB
- Unibrake

		Model	Description / Application
Static Engage	See Catalog P-8589-WE	ERS 	The ERS family of brakes is a spring set/ electrically released design. Excellent for use in holding applications. Torque ranges from 1.5 to 100 foot pounds.
		ERD 	The ERD family of brakes is a spring set/ electrically released design similar in concept to the ERS designs. The ERD family extends the torque ratings from 3 to 220 foot pounds. The ERD family also includes an adjustable torque option and manual release option.
		EM/ERS 	For C-face mounted applications the EM/ERS provides the ERS design with the easy to mount C-face mounting.
Dynamic Engage	See Catalog P-8590-WE	ER 	ER brakes provide a permanent magnet engage/ electrically released design. The customer assembled design of the ER family allows for ease of installation into unique customer applications requiring torque ranges from 10 to 400 foot pounds.
		FB 	The bearing mounted FB products are a permanent magnet engage/electrically released design. The bearing mounted design allows for simple mounting using just a torque arm for applications where a pre- assembled unit is desired and no mounting flange is available. Torque ranges from 10 to 56 foot pounds.
		FBB 	The C-face mount FBB units are designed to mount on the output side of a C-face motor where a brake only configuration is appropriate.
		MBFB 	The MBFB designs are the same as the FBB, except they are for the back of motor mounting for double C-face motors.
		FBC 	The C-face mount FBC units are designed to work with the clutch design for applications needing an electrically engaged clutch and electrically released brake.
See Catalog P-8589-WE		Unibrake 	The Unibrake designs are a spring set/ solenoid release brake for mounting to the back of the motor. This is a lower cost, lower cycle rate design compared to the MBFB. Adjustable torque and manual release are standard features.
		Unibrake Coupler 	The coupler design of the Unibrake family is designed for mounting on the output side of a motor where a spring set/solenoid release brake is desired. Adjustable torque and manual release are standard features.



# Selection Guide Electrically Released Brakes

	Load Holding	Manual Release	Bearing Mount	Flange Mount	C-Face Mtg Drive Side	C-Face Mtg Non-Drive Side	Coil Voltage	Adjustable Torque
	✓						DC	
	✓	✓					DC	✓
	✓				✓		DC	
	✓			✓			DC	✓
	✓		✓				DC	✓
	✓				✓		DC	✓
	✓					✓	DC	✓
	✓				✓		DC	✓
	✓	✓				✓	AC	✓
	✓	✓			✓		DC or AC	✓

# Permanent Magnet Electrically Released Brakes

## Permanent Magnet Brakes

Frequent cycling applications which regularly engage the brake to stop a moving load call for FB or ER models. Frequent cycling keeps working surfaces burnished and operating at top efficiency. The convenience of power off braking combines with stopping capability in the event of power failure to provide the ideal brake for many applications.

### FB Series (Shaft Mounted)

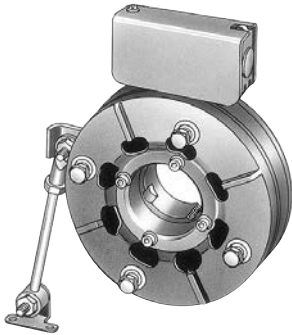

FB Series permanent magnet brakes are offered as off-the-shelf, pre-assembled packages in three sizes. Packaged products are easy to install.

### ER Series (Flange Mounted)



ER Series permanent magnet brakes allow customers added flexibility and larger sizes. 825 and 1225 are available in both standard and heavy duty models.

### Principle of Operation

Electrically Released Brakes automatically engage when the power goes off. Reliable permanent magnets provide a permanent holding force. Electrical power applied to the coil nullifies the attraction of the permanent magnet and the brake releases. No power is required to stop or hold a load.

### Packaged Convenience for Power Off Applications

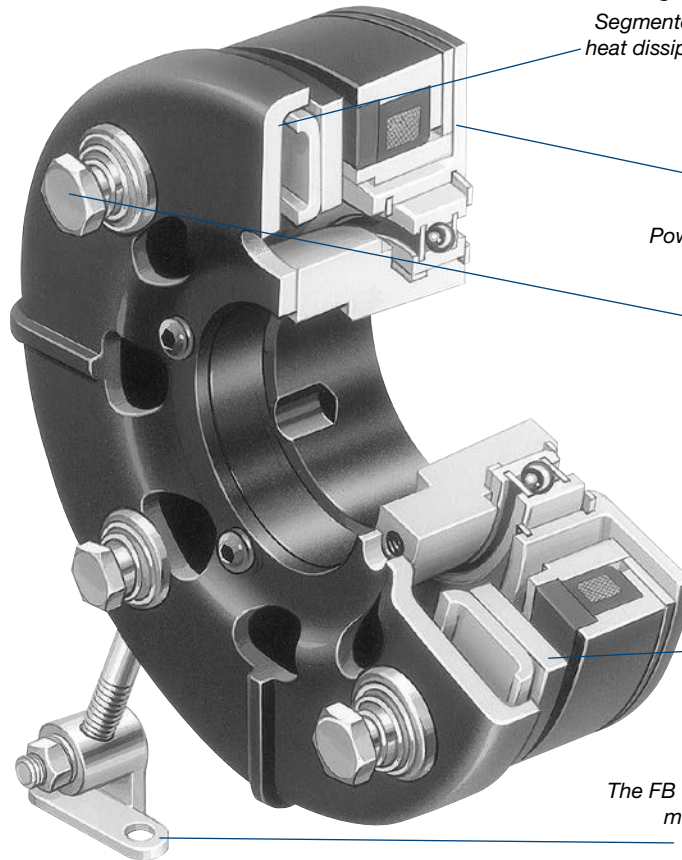

#### Long Life – High Cycle Rates

Segmented armature provides high heat dissipation and long service life. Capable of rapid cycling.

#### High Torque

Powerful permanent magnets.

#### Autogap™

Automatic wear adjust.

#### Electrically Released

Brake automatically engages when power is turned off– releases when power is applied.

#### Mounting Flexibility

The FB torque arm feature permits mounting on any shaft. Wide range of shaft sizes.

### FB Magnetically Set, Electrically Released, Dynamic Engagement Brake

Packaged brake assembly complete with conduit box is ready to install.

This brake must be engaged while the shaft is in motion. Shaft speed should be 100 RPM or greater when the brake is engaged. This style brake offers quick and easy bearing mounting on the shaft, high cycle rate capability, and excellent life.

FB Brake on double shaft motor.

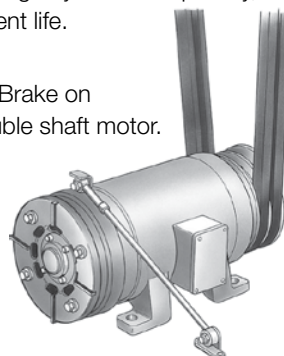

### Features

- Designed for dynamic stopping operations
- Brake automatically engages when power is turned off
- High cycle rate capability
- Never needs adjustment – automatically compensates for wear
- Mounting flexibility
- Powerful permanent magnets
- Segmented armature design provides high heat dissipation and long service life.
- Complete controllability for soft stops.
- UL listed

# FB Series Electrically Released Brakes

## Selection/Ordering Information

### Selection Procedure

FB (Shaft Mounted) Series brakes are available in three models to provide an optimum size to match your application requirements. Static torque capabilities range from 10.5 lb.ft. to 56 lb.ft.

1. Verify that the brake will be cycled frequently in normal operation.
2. Determine the horsepower and speed at the brake location.
3. The correct size Electrically Released Brake is shown at the intersection of the HP and shaft speed on the chart below.
4. Available bore sizes are listed in the bore data chart. When ordering, specify voltage and bore size.
5. Five motor adapters are also available for mounting Electrically Released Brakes on single shaft extension motors (see motor adapter bore size chart on page A-6). For double shaft extension motors, the adapter can be eliminated. Specify motor shaft size.

### How to Order

1. Specify brake part number.
2. For FB-475 and FB-650, order bushing separately (see page A-9). FB-375 does not require a bushing.
3. For single shaft motor mounting, order adapter separately (Item 2 below). Specify the following bore size for the FB brake. This is the bore size required for mounting the electrically released brake on the end of the motor adapter.  
 FB-375 5/8" bore  
 FB-475 1 bore  
 FB-650 1-3/8" bore
4. See the Controls Section for controls. FB Series brakes require a control with a potentiometer to vary brake channel output. CBC-300 or 500/550 are recommended.

### Horsepower vs. Shaft Speed\*

HP	SHAFT SPEED AT BRAKE (IN RPM)*																				
	100	200	300	400	500	600	700	800	900	1000	1100	1200	1500	1800	2000	2400	3000	3600	4000	4500	
1/12																					
1/8																					
1/6																					
1/4																					
1/3																					
1/2																					
3/4																					
1																					
1-1/2																					
2																					
3																					
5																					
7-1/2																					
10																					
15																					

\* For applications which require stopping below 100 RPM, consult factory.

### Specifications

Model	Voltage DC	Static Torque (lb.ft.)	Max. RPM	Total Weight (lbs.)
FB-375	24V	10.5	5000	4.5
	90V			
FB-475	24V	21	4500	6.3
	90V			
FB-650	24V	56	3600	13.2
	90V			

### Electrically Released Brake Assemblies

Unit Size	Bore	Voltage DC	Part Number
FB-375	1/2"	24	5390-170-024
FB-375	1/2"	90	5390-170-021
FB-375	5/8"	24	5390-170-023
FB-375	5/8"	90	5390-170-022
FB-475	—	24	5391-170-012
FB-475	—	90	5391-170-009
FB-650	—	24	5392-170-010
FB-650	—	90	5392-170-007

### Typical Application

#### Storage Elevator

These brakes will stop as well as keep a load in position until they are electrically released. They are also used as emergency stopping devices.

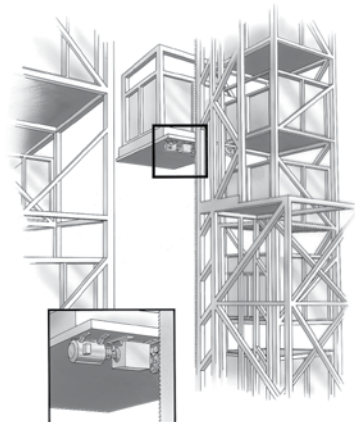

# Permanent Magnet Electrically Released Brakes

## Motor and Shaft Adapters

### Motor Adapter Bore Sizes

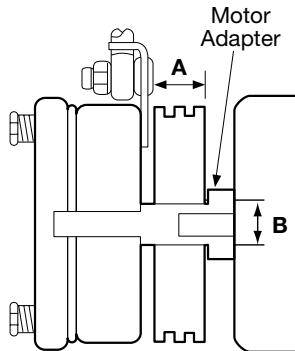

Model Size	Motor Shaft Size	A Usable Length	B Dia.	When using an adapter order the following	
				Adapter	Dodge Bushing
375	.625	2.000	.875	5380-101-005	*None
	.875	2.250	1.250	5380-101-004	*None
475	1.125	2.750	1.625	5381-101-003	#1008 1"
	1.375	3.000	2.000	5382-101-003	#1310 1.375"
650	1.625	3.625	2.250	5382-101-002	#1310 1.375"

\*Order FB-375 with 5/8" bore.

### FB Shaft Adapter

Shown below are dimensions and specifications for the optional shaft adapter available for mounting FB Series brakes on a motor. A standard sheave, pulley, or sprocket, with either a tapered bushing or straight bore, can be installed on the shaft adapter. The brake is mounted on the end of the shaft adapter and the complete assembly fits onto the motor shaft, secured with setscrews. Fitting the belts or chain and torque arm completes the installation.

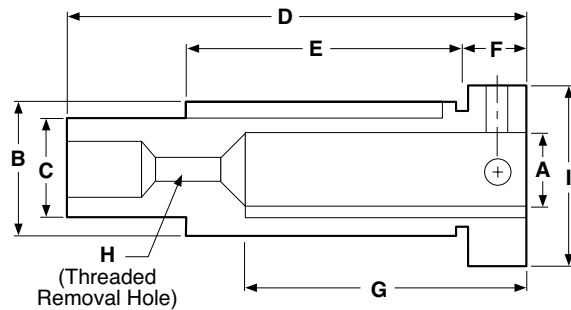

Model	A	Kwy.	B	Kwy.	Key Part No.	C	Kwy.	Key Part No.	Dodge Bushing Size	D	E	F	G	H	I
FB-375	5/8	3/16 x 3/32	7/8	3/16 x 3/32	590-0016	5/8	3/16 x 3/32	590-0043	None	4.391 4.359	2	.391 .359	2	1/4-20 UNC	1.125
FB-375	7/8	3/16 x 3/32	1-1/4	1/4 x 1/8	590-0022	5/8	3/16 x 3/32	590-0043	None	4.578 4.742	2-1/4	.516 .484	2-1/4	1/4-20 UNC	1.500
FB-475	1-1/8	1/4 x 1/8	1-5/8	3/8 x 3/16	590-0041	1	1/4 x 1/8	—	#1008 1"	4.516 4.484	2-3/4	.641 .609	2-3/4	1/2-13 UNC	1.750
FB-650	1-3/8	5/16 x 5/32	2	1/2 x 1/4	590-0042	1-3/8	5/16 x 5/32	590-0044	#1310 1-3/8"	5.547 5.515	3-3/8	.641 .609	3-3/8	1/2-13 UNC	2.125
FB-650	1-5/8	3/8 x 3/16	2-1/4	1/2 x 1/4	590-0042	1-3/8	5/16 x 5/32	590-0044	#1310 1-3/8"	6.172 6.140	4	.641 .609	4	1/2-13 UNC	2.375

All dimensions are nominal unless otherwise noted.



# FB Series Electrically Released Brakes

FB-375, FB-475, FB-650

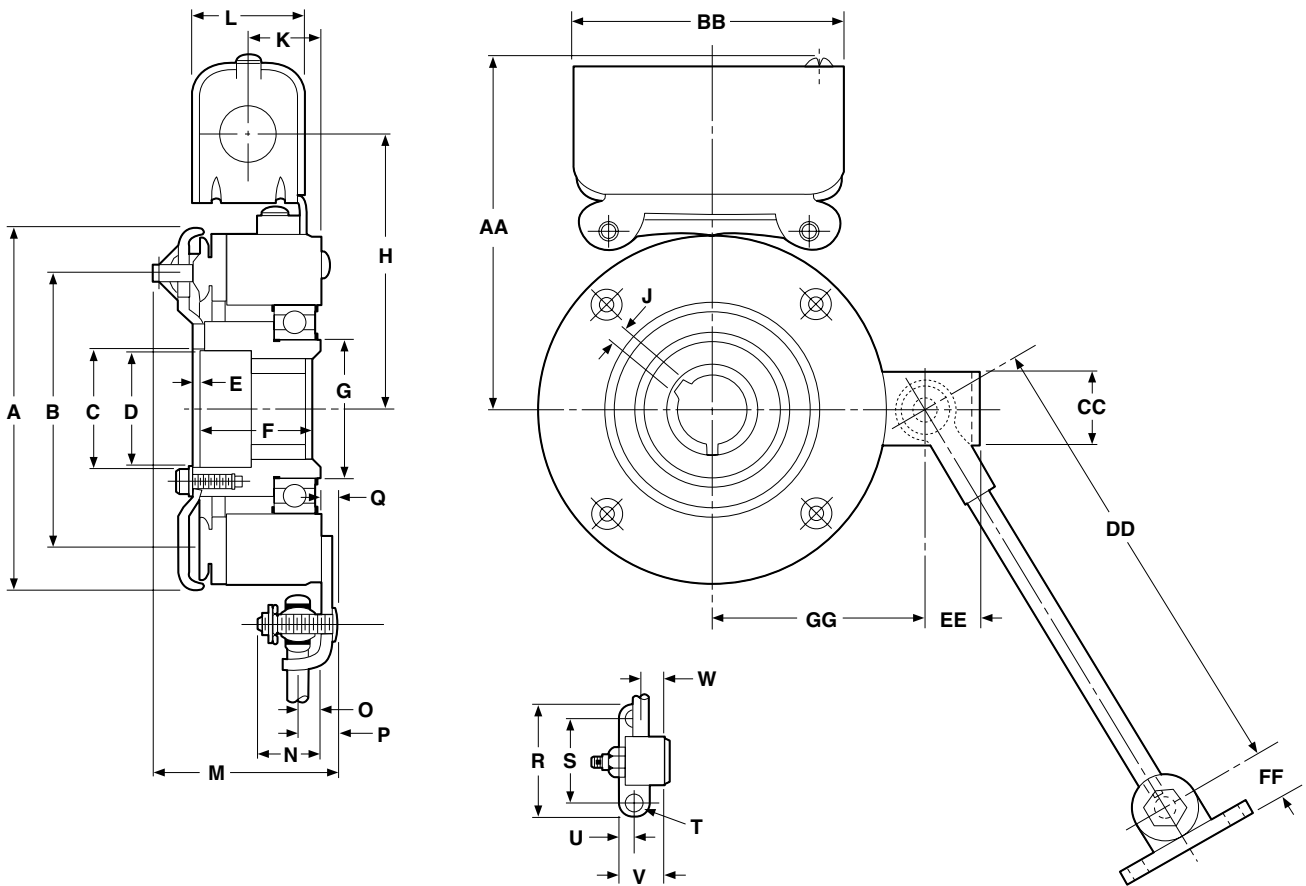

## Dimensions

All dimensions are nominal, unless otherwise noted.

Size	A	B	C	D	E	F	G	H	J	K	L	M	N	O	P
	Max.	Dia	Min.	Dia.	Min.		Dia.					Max.			
375	4.078	3.125	.7505	—	.031	1.906	1.375	3.359	.187	1.281	1.546	2.716	.843	.281	.531
475	5.171	4.000	1.663	1.593	—	1.875	1.781	3.875	—	1.218	1.546	3.390	1.093	.312	.531
650	6.578	5.125	2.343	2.281	—	2.250	2.562	4.800	—	1.550	1.546	3.765	1.031	.343	.640

Size	Q	R	S	T	U	V	W	AA	BB	CC	DD	EE	FF	GG
	Max.		Dia.					Max.						
375	—	2.000	1.500	.270	.270 .260	.781	.359	4.468	3.750	1.000	8.000	.666	.635	2.578
475	.281	2.000	1.500	.270	.270 .260	.781	.390	4.984	3.750	1.000	10.000	.697	.635	3.094
650	.359	2.000	1.500	.270	.270 .260	.781	.437	5.843	3.750	1.125	11.000	.843	.635	4.062

## Bore Data (Key furnished)

Size	Bore Dia.	Keyway
FB-375	.626/.625	3/16 x 3/32
	.501/.500	1/8 x 1/16
FB-475	.500 - .562	1/8 x 1/16
Dodge #1008	.625 - .875	3/16 x 3/32
	.937 - 1.000	1/4 x 1/8
	.500 - .562	1/8 x 1/16
FB-650	.625 - .875	3/16 x 3/32
Dodge #1310	.937 - 1.250	1/4 x 1/8
	1.312 - 1.375	5/16 x 5/32

Note: FB-375 has a straight bore. Bushing not required.  
Bushings also available in metric bores. See page A-9.

# ER Series Electrically Released Brakes

## Ideal for Dynamic Braking Applications

### ER Series Dynamic Engagement Brakes

This brake must be engaged while the shaft is in motion. Shaft speed should be 100 RPM or greater when the brake is engaged. This style brake offers a bulkhead flange mounting system, the highest torque rating offered by Warner Electric in the power released series, high cycle rate capability, and excellent life.

- Expands the electrically released product family with two larger sizes
- Designed for dynamic stopping operations
- High cycle rate capability
- Inside or outside mount options for 475 or 650 sizes
- Normal or heavy duty options available in larger sizes

### Selection Procedure

ER Series brakes are available in five sizes. Static torque ratings range from 10.5 lb.ft. to 400 lb.ft.

1. Verify that the brake will be cycled frequently in normal operation.
2. Determine the horsepower and speed at the brake location.
3. The correct size ER Series brake is shown at the intersection of the HP and shaft speed.
4. When ordering, specify voltage and bore size. Available bore sizes are listed in the specifications chart.

### How to Order

1. Specify model number
2. For thru-shaft mounting, specify bore size. For ER-475 and ER-650 order bushing separately, ER-375 does not require a bushing.
3. Models ER-475 and ER-650: Specify inside or outside mount. Models ER-825 and ER-1225: Specify normal or heavy duty.
4. See the Controls Section for controls. ER Series brakes require a control with a potentiometer to vary brake channel output. Recommended are:  
For ER-825 use CBC-500, or -550.  
For ER-1225, use MCS-805-1 or -2.

### Flange Mounted Brakes



*Powerful permanent magnets.*

*Never needs adjustment—automatically compensates for wear.*

*Brake automatically engages when power is turned off.*

*Pre-burnished to assure rated torque upon installation.*

*Segmented armature design provides high heat dissipation and long service life.*

### Horsepower vs. Shaft Speed

HP	SHAFT SPEED AT BRAKE (IN RPM)																			
	100	200	300	400	500	600	700	800	900	1000	1100	1200	1500	1800	2000	2400	3000	3600	4000	4500
1/12																				
1/8																				
1/6																				
1/4																				
1/3																				
1/2																				
3/4																				
1																				
1-1/2																				
2																				
3																				
5																				
7-1/2																				
10																				
15																				
20																				
25																				
30																				
40																				
50																				
60																				
75																				

\*For applications with speeds below 100RPM, please contact Warner Electric Application Support.

# ER Series Electrically Released Brakes

## Specifications

Model	Bore Size	Voltage DC	Static Torque lb. ft.	Max. RPM	Drive	Inertia lb.ft.2		Weight lbs.		Total
						Arm. & Carrier	Hub	Arm. & Carrier	Hub	Weight lbs.
ER-375	.500" & .625"	90V	10.5	5000	-	.010	.001	.60	.49	4.5
ER-475	.500" to 1.000" Dodge #1008	90V	21	4500	-	.072	.006	1.13		6.3
ER-650	.500" to 1.375" Dodge #1310	90V	56	3600	-	.106	.020	2.3	1.6	13.2
ER-825 ND	.500" to 1.625" Dodge #1615	90V, 24V	125	3600	Pin Spline	.323 .326	.043 .006	4.783 5.263	1.857 .834	15.6
ER-825 HD	.500" to 1.500" Browning #H-1	90V, 24V	125	3600	Pin Spline	.323 .326	.043 .006	4.783 5.263	1.857 .834	15.6
ER-1225 ND	.937" to 3.00" Dodge #3030	35-75V	400	3000	Pin Spline	1.667 1.737	.380 .077	10.227 13.317	6.716 3.582	60.3
ER-1225 HD	.75" to 2.687" Browning #Q-1	35-75V	400	3000	Pin Spline	1.667 1.737	.380 .077	10.227 13.317	6.716 3.582	60.3

## Bushing Part Numbers

Bushing Number				Bushing Number				Bushing Number			
Shaft Size	Keyway Size	Warner Electric	Browning	Shaft Size	Keyway Size	Warner Electric	Browning	Shaft Size	Keyway Size	Warner Electric	Browning
1/2	1/8 x 1/16	180-0002		2-5/16	5/8 x 5/16	180-0051		1-15/16	1/2 x 1/4	180-0278	
9/16	1/8 x 1/16	180-0003		2-3/8	5/8 x 5/16	180-0052		2	1/2 x 1/4	180-0279	
5/8	3/16 x 3/32	180-0004		2-7/16	5/8 x 5/16	180-0053		2-1/16	1/2 x 1/4	180-0280	
11/16	3/16 x 3/32	180-0005		2-1/2	5/8 x 5/16	180-0054	QI-2	2-1/8	1/2 x 1/4	180-0281	
3/4	3/16 x 3/32	180-0006		2-9/16	5/8 x 5/16	180-0055		2-3/16	1/2 x 1/4	180-0282	
13/16	3/16 x 3/32	180-0007		2-5/8	5/8 x 5/16	180-0056		2-1/4	1/2 x 1/4	180-0283	
7/8	3/16 x 3/32	180-0008		2-11/16	5/8 x 5/16	180-0057		2-5/16	5/8 x 5/16	180-0284	
15/16	1/4 x 1/8	180-0009	H-1	1/2	1/8 x 1/16	180-0131		2-3/8	5/8 x 5/16	180-0285	
1	1/4 x 1/8	180-0010		9/16	1/8 x 1/16	180-0132		2-7/16	5/8 x 5/16	180-0286	3030
1-1/16	1/4 x 1/8	180-0011		5/8	3/16 x 3/32	180-0133		2-1/2	5/8 x 5/16	180-0287	
1-1/8	1/4 x 1/8	180-0012		11/16	3/16 x 3/32	180-0134		2-9/16	5/8 x 5/16	180-0288	
1-3/16	1/4 x 1/8	180-0013		3/4	3/16 x 3/32	180-0135		2-5/8	5/8 x 5/16	180-0289	
1-1/4	1/4 x 1/8	180-0014		13/16	3/16 x 3/32	180-0136		2-11/16	5/8 x 5/16	180-0290	
1-5/16	5/16 x 5/32	180-0015		7/8	3/16 x 3/32	180-0137		2-3/4	5/8 x 5/16	180-0291	
1-3/8	5/16 x 5/32	180-0016		15/16	1/4 x 1/8	180-0138		2-13/16	3/4 x 3/8	180-0292	
1-7/16	3/8 x 3/16	180-0017	H-2	1	1/4 x 1/8	180-0139		2-7/8	3/4 x 3/8	180-0293	
1-1/2	3/8 x 3/16	180-0018		1-1/16	1/4 x 1/8	180-0140	1615	2-15/16	3/4 x 3/8	180-0294	
3/4	3/16 x 3/32	180-0026		1-1/8	1/4 x 1/8	180-0141		3	3/4 x 3/8	180-0295	
13/16	3/16 x 3/32	180-0027		1-3/16	1/4 x 1/8	180-0142		1/2	1/8 x 1/16	180-0410	
7/8	3/16 x 3/32	180-0028		1-1/4	1/4 x 1/8	180-0143		9/16	1/8 x 1/16	180-0411	
15/16	1/4 x 1/8	180-0029		1-5/16	5/16 x 5/32	180-0144		5/8	3/16 x 3/32	180-0412	
1	1/4 x 1/8	180-0030		1-3/8	5/16 x 5/32	180-0145		11/16	3/16 x 3/32	180-0413	
1-1/16	1/4 x 1/8	180-0031		1-7/16	3/8 x 3/16	180-0146		3/4	3/16 x 3/32	180-0414	1008
1-1/8	1/4 x 1/8	180-0032		1-1/2	3/8 x 3/16	180-0147		13/16	3/16 x 3/32	180-0415	
1-3/16	1/4 x 1/8	180-0033		1-9/16	3/8 x 3/16	180-0148		7/8	3/16 x 3/32	180-0416	
1-1/4	1/4 x 1/8	180-0034		1-5/8	3/8 x 3/16	180-0149		15/16	1/4 x 1/16	180-0417	
1-5/16	5/16 x 5/32	180-0035	QI-1	15/16	1/4 x 1/8	180-0262		1	1/4 x 1/16	180-0418	
1-3/8	5/16 x 5/32	180-0036		1	1/4 x 1/8	180-0263		1/2	1/8 x 1/16	180-0421	
1-7/16	3/8 x 3/16	180-0037		1-1/16	1/4 x 1/8	180-0264		9/16	1/8 x 1/16	180-0422	
1-1/2	3/8 x 3/16	180-0038		1-1/8	1/4 x 1/8	180-0265		5/8	3/16 x 3/32	180-0423	
1-9/16	3/8 x 3/16	180-0039		1-3/16	1/4 x 1/8	180-0266		11/16	3/16 x 3/32	180-0424	
1-5/8	3/8 x 3/16	180-0040		1-1/4	1/4 x 1/8	180-0267		3/4	3/16 x 3/32	180-0425	
1-11/16	3/8 x 3/16	180-0041		1-5/16	5/16 x 5/32	180-0268		13/16	3/16 x 3/32	180-0426	
1-3/4	3/8 x 3/16	180-0042		1-3/8	5/16 x 5/32	180-0269		7/8	3/16 x 3/32	180-0427	
1-13/16	1/2 x 1/4	180-0043		1-7/16	3/8 x 3/16	180-0270	3030	15/16	1/4 x 1/16	180-0428	1310
1-7/8	1/2 x 1/4	180-0044		1-1/2	3/8 x 3/16	180-0271		1	1/4 x 1/8	180-0429	
1-15/16	1/2 x 1/4	180-0045		1-9/16	3/8 x 3/16	180-0272		1-1/16	1/4 x 1/8	180-0430	
2	1/2 x 1/4	180-0046		1-5/8	3/8 x 3/16	180-0273		1-1/8	1/4 x 1/8	180-0431	
2-1/16	1/2 x 1/4	180-0047		1-11/16	3/8 x 3/16	180-0274		1-3/16	1/4 x 1/8	180-0432	
2-1/8	1/2 x 1/4	180-0048	QI-2	1-3/4	3/8 x 3/16	180-0275		1-1/4	1/4 x 1/8	180-0433	
2-3/16	1/2 x 1/4	180-0049		1-13/16	1/2 x 1/4	180-0276		1-5/16	15/16 x 5/32	180-0434	
2-1/4	1/2 x 1/4	180-0050		1-7/8	1/2 x 1/4	180-0277		1-3/8	15/16 x 5/32	180-0435	

Browning® is registered to Emerson Electric Co.  
Dodge and Browning bushings are also available in metric bores.

# ER Series Electrically Released Brakes

## ER-375, ER-475, ER-650

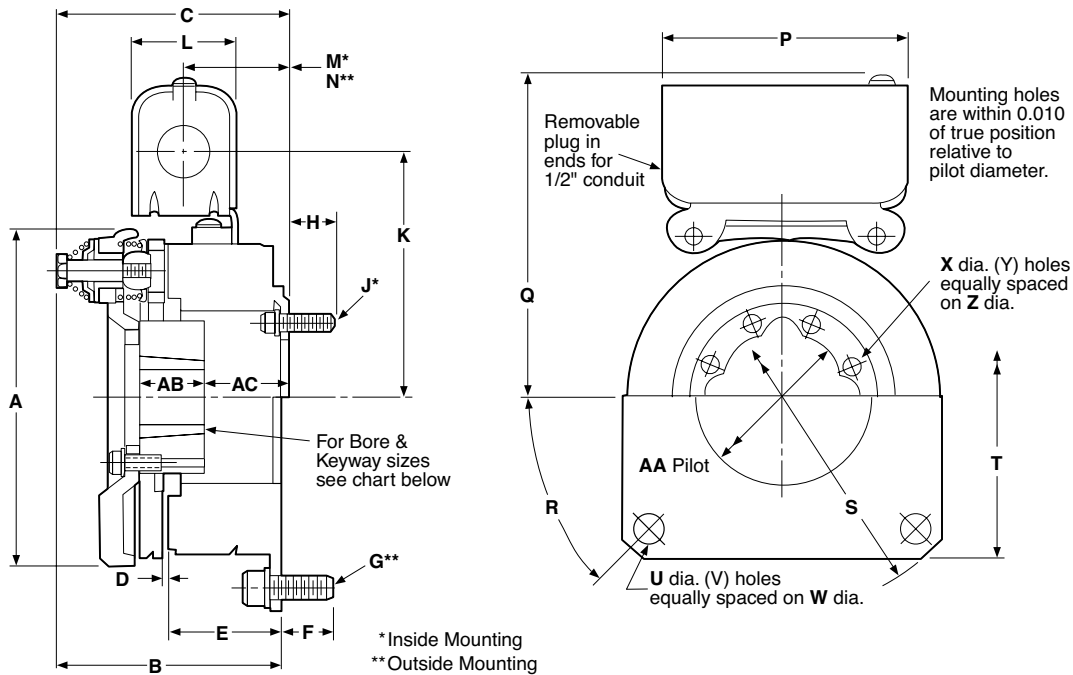

### Dimensions

All dimensions are nominal, unless otherwise noted.

Size	A Max.	B Max.	C Max.	D	E	F Max.	G	H Max.	J	K	L	M	N	P
375	4.078	2.583	2.583	.032	1.410	.600	5/16-18 UNC-3A	—	—	3.325	1.547	—	—	3.750
475	5.172	3.195	3.274	.031	1.630	.431	3/8-16 UNC-3A	.390	8-32	3.875	1.547	1.354	1.236	3.750
650	6.578	3.525	3.525	.032	1.880	.542	5/16-18 UNC-3A	.542	5/16-18 UNC-3A	4.800	1.547	—	—	3.750

Size	Q Max.	R	S	T Sq.	U	V	W Dia.	X	Y	Z Dia.	AA Dia.	AB	AC
375	4.505	—	5.625 5.623	—	.350 .341	3	5.000	—	—	—	—	23/32	1-3/4
475	5.000	45°	6.500 6.498	5.000	.419 .403	4	5.875	.208 .201	8	2.375	2.065 2.062	29/32	1-3/16 I.M. 1-1/16 O.M.
650	5.844	45°	8.000 7.998	6.500	.358 .338	4	7.250	.358 .338	4	3.688	2.822 2.820	1-1/32	1-3/8

### Mounting Requirements

Customer Shall Maintain:

1. Squareness of brake mounting face with armature hub shaft within .006 T.I.R.
2. Concentricity of brake mounting pilot diameter with armature hub shaft within .010 T.I.R.

3. If magnet mounting surface is a magnetic material, the magnet is to be insulated approximately 1/2" from that surface with a plate or spacers of non-magnetic material.

ER-375 available outside mounted only.

### Bore and Keyway Dimensions

Size	Bore Dia.	Keyway
375	.501/.500	1/8 x 1/16
	.626/.625	3/16 x 3/32
475	.500 - .562	1/8 x 1/16
	.625 - .875	3/16 x 3/32
650	.937 - 1.000	1/4 x 1/8
	.500 - .562	1/8 x 1/16
	.625 - .875	3/16 x 3/32
	1.000 - 1.250	1/4 x 1/8
	1.312 - 1.375	5/16 x 5/32



# ER Series Electrically Released Brakes

## ER-825, ER-1225

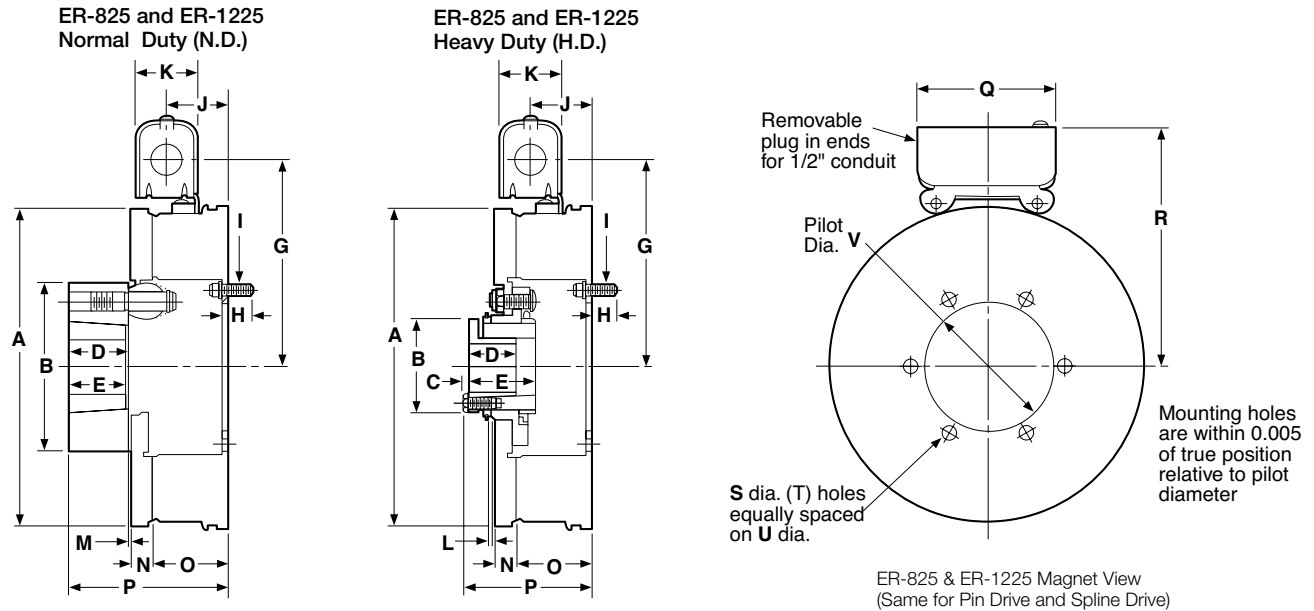

ER-825 & ER-1225 Magnet View  
(Same for Pin Drive and Spline Drive)

Size	A		B		C	D	E	G	H		I	J	K	L
	Max.	Dia.	Max.	Min.					Max.	Min.				
825 N.D.	8.656	4.625	—	1.593	1.500	5.625	.531	5/16-18 UNC-3A	1.687	1.546	—			
825 H.D.	8.656	2.500	.156	1.250	1.765	5.625	.531	5/16-18 UNC-3A	1.687	1.546	.062			
1225 N.D.	12.671	6.875	—	3.000	3.000	7.671	.546	5/16-18 UNC-3A	1.718	1.546	—			
1225 H.D.	12.671	4.093	.234	2.500	2.171	7.671	.546	5/16-18 UNC-3A	1.718	1.546	.062			

Size	M		N	P		Q	R		S	T	U	V
	When New	Max.		Max.	Max.							
825 N.D.	.093	.562	2.080 .338	4.359	3.750	6.750 3.501	.358	6	4.250	3.503		
825 H.D.	—	.531	2.080 .338	3.546	3.750	6.750 3.501	.358	6	4.250	3.503		
1225 N.D.	.156	.593	2.500 .338	6.218	3.750	8.796 6.376	.358	6	7.250	6.378		
1225 H.D.	—	.562	2.500 .338	5.031	3.750	8.796 6.376	.358	6	7.250	6.378		

### Mounting Requirements

Customer Shall Maintain

1. Squareness of magnet mounting face with armature shaft within .006 T.I.R.
2. Concentricity of magnet mounting pilot diameter with armature shaft within .010 T.I.R.
3. If magnet mounting surface is a magnetic material, the magnet is to be insulated approximately 1/2" from that surface with a plate or spacers of non-magnetic material.

### Bore and Keyway Dimensions

ER-825	Bore Dia.	Keyway
<b>Pin Drive</b>	.500 - .562	1/8 x 1/16
	.625 - .875	3/16 x 3/32
	.937 - 1.250	1/4 x 1/8
	1.312 - 1.375	5/16 x 5/32
<b>Spline Drive</b>	1.437 - 1.500	3/8 x 3/16
	1.562 - 1.625*	3/8 x 3/16
	.500 - .562	1/8 x 1/16
	.375 - .625	3/16 x 3/32
<b>ER-1225</b>	.937 - 1.187	1/4 x 1/8
	1.250*	1/4 x 1/8
	1.312 - 1.375*	5/16 x 5/32
	1.437 - 1.500*	3/8 x 3/16
<b>Pin Drive</b>	.937 - 1.250	1/4 x 1/8
	1.312 - 1.375	5/16 x 5/32
	1.437 - 1.750	3/8 x 3/16
	1.812 - 2.250	1/2 x 1/4
<b>Spline Drive</b>	2.312 - 2.750	5/8 x 5/16
	2.187 - 3.000*	3/4 x 3/8
	.750 - .875	3/16 x 3/32
	.937 - 1.250	1/4 x 1/8
	1.312 - 1.375	5/16 x 5/32
	1.437 - 1.750	3/8 x 3/16
	1.812 - 2.062	1/2 x 1/4
	2.125 - 2.250*	1/2 x 1/4
	2.312 - 2.687	5/8 x 5/16

\*Key furnished

# Electrically Released NEMA C-face Brakes

## For Dynamic Stopping and Cycling Applications

Warner Electric's modular design brakes and clutch/brake units offer material handling system users a high performance alternative to spring-set brakes. These modular units provide long life, maintenance free operation, and consistent performance with minimal downtime.

These brakes are offered in power-off types for double shaft motors and for installation between C-face motor and reducer or other drive device. Powerful permanent magnets generate braking torque. The brakes release when voltage is applied to the coil, countering the force of the permanent magnets. No power is required to stop or hold a load. An optional integral conduit box provides simple wiring direct from the motor power leads.

- Designed for dynamic stopping operations
- Brake automatically engages when power is turned off
- High cycle rate capability
- Never needs adjustment – automatically compensates for wear
- Powerful permanent magnets provide braking force
- Choice of open or enclosed brakes
- Prepackaged, preburnished UM version



# Electrically Released NEMA C-face Brakes

## UM Series (UniModule Clutch/Brakes)

**Pre-assembled clutch/electrically released brake modules**



- The UM-1020-FBC brake/motor clutch combination is used for clutch/power-off brake applications. It mounts directly to C-face compatible components.
- The UM-2030-FBC brake/input clutch combination is used for clutch/power-off brake applications. It has shafts on both the input and output sides for base mounting.
- Sizes 50, 100, 180 can be enclosed with optional cover kit.

## EUM Series (Enclosed Motor Brakes)

**Totally enclosed non-vented units that keep wear particles in and contaminants out**



- The EUM-FBB brake unit can be mounted between two C-face compatible components.
- The EUM-MBFB motor brake is mounted directly to the rear of a double-shafted motor.

## EM Series (Electro Module Brakes and Clutch/Brakes)

**Comprised of individual units that may bolt together to form various combinations**



- The EM-FBB brake module mounts between a C-face motor and a gear box or reducer.
- The EM-MBFB motor brake module is mounted to the rear of a double-shafted motor.
- The EM-FBC brake module is used in combination with a motor clutch or input clutch unit to make a clutch/electrically released brake or can be used alone as a brake only.
- Sizes 50, 100, 180 can be enclosed with optional cover kit.

# UM-FBC Series Electrically Released NEMA C-face Brakes

## UniModule Clutch/Electrically Released Brake Combination

Warner Electric offers the convenience of pre-assembled UniModule clutch/electrically released brake packages. Assembly, alignment, and pre-burnishing have been done at the factory. Bolt it on, wire it up, and your clutch/electrically released brake is ready to go. Available in both C-face and base mounted versions.

Warner Electric's unique design employs powerful permanent magnets for maximum torque when power is removed from the brake coil. A small amount of electrical power applied to the brake coil nullifies the permanent magnets and the brake releases. No springs to limit cycle rates. Never any adjustments. No lubrication. These brakes are recommended for dynamic cycling operations only.



Sizes 50, 100 & 180

Sizes 210 & 215



### 1020-FBC

#### Motor Clutch/Electrically Released Brake

Use for clutch/power-off brake applications. Has clutch input and brake on output side. Employs powerful permanent magnets for maximum torque when power is removed from the brake coil. Basic components are field, rotor, 2 armatures and power-off magnet. See page A-19 for specifications.



### 2030-FBC

#### Input Clutch/Electrically Released Brake

Use for clutch/power-off brake applications. Has shafts on input and output sides. When electrical power is applied to the brake coil the brake releases. Ideal for dynamic cycling operations. Basic components are field, rotor, 2 armatures and power-off magnet. See page A-20 for specifications.



### 2030-FBC-B

#### Input Clutch/Electrically Released Brake with Accessory Base Mounting

See page A-20 for specifications.

# UM-FBC Series Electrically Released NEMA C-face Brakes

## Selection

UniModule clutch/electrically released brake units may be mounted directly to NEMA C-face motors and reducers, or can be base mounted.

### 1. Select Configuration

#### a. NEMA C-face Mounting (1020 Configuration)

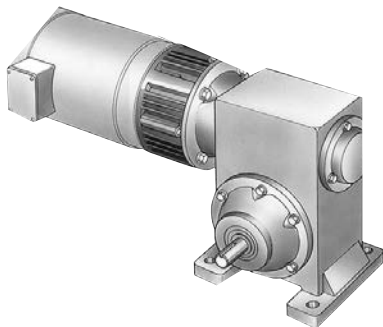

Verify the unit will be cycled frequently.

To select the correct UniModule package, determine the NEMA frame size of your motor and/or reducer, and choose the corresponding size UniModule from the Frame Size Selection chart. Verify torque ratings.

#### b. Base Mounting (2030 Configuration)

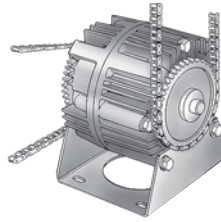

Verify the unit will be cycled frequently.

Select the correct size module from the Horsepower vs. Shaft Speed chart by determining the motor horsepower and RPM at the module location. The correct size UniModule is shown at the intersection of the HP and operating speed. For additional sizing information, refer to the technical sizing procedure (step 2).

### 2. Determine Technical Requirements

Technical considerations for sizing and selection are torque and heat dissipation. Each merits careful consideration, especially heat dissipation as over time, use in excessive temperature environments will have an adverse effect on bearing life and coil wire insulation integrity.

Compare the calculated torque requirement with the average dynamic torque ratings. Select a unit with adequate torque. If the unit selected on torque is different than the unit selected based on heat, select the larger size unit.

### Horsepower vs. Shaft Speed

HP	SHAFT SPEED AT CLUTCH (IN RPM)																		
	100	200	300	400	500	600	700	800	900	1000	1100	1200	1500	1800	2000	2400	3000	3600	
1/4																			
1/2																			
3/4																			
1																			
1-1/2																			
2																			
3																			
5																			
7-1/2																			

\*For applications with speeds below 100RPM, please contact Warner Electric Application Support.

### Frame Size Selection and Technical Ratings Chart

NEMA Frame Size	UniModule Size	Static Torque Brake lb.ft.	Static Torque Clutch lb.ft.	Max. RPM	Voltage DC
56C/48Y	UM-50*	10.5	16	3600	24 or 90
	UM-100**	21	30		
182C/143TC	UM-180	21	30	3600	24 or 90
184C/145TC					
213C/182TC	UM-210	56	95	3600	24 or 90
215C/184TC					
213TC/215TC					

\*For 56C/48Y C-frame motors 3/4 HP and smaller, the UM-100 size may be used where extended life is desirable.

\*\*The UM-100 size is recommended for motors 1 HP and larger.

# UM-FBC Series Electrically Released NEMA C-face Brakes

## a. Heat Dissipation Sizing

Friction surfaces slip during the initial period of engagement and, as a result, heat is generated. The clutch/brake selected must have a heat dissipation rating greater than the heat generated by the application. Therefore, in high inertia or high cycle rate applications, it is necessary to check the heat dissipation carefully. Inertia, speed and cycle rate are the required parameters.

Heat dissipation requirement is calculated as follows:

$$E = 1.7 \times WR^2 \times (N/100)^2 \times F$$

where:

$$E = \text{Heat (lb. ft./min.)}$$

$WR^2$  = Total reflected inertia at the clutch/brake shaft. Include the clutch/brake output inertia. (lb.ft.<sup>2</sup>)

N = Speed in revolutions per minute (RPM)

F = Cycle rate in cycles per minute (CPM)

Compare the calculated heat generated in the application to the unit ratings using the heat dissipation curves. Select the appropriate unit that has adequate heat dissipation ability.

## Heat Dissipation Curves

### Size 50

Maximum Speed 3600 RPM

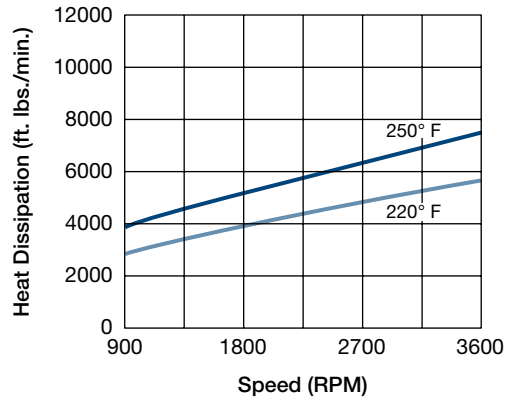

### Size 100/180

Maximum Speed 3600 RPM

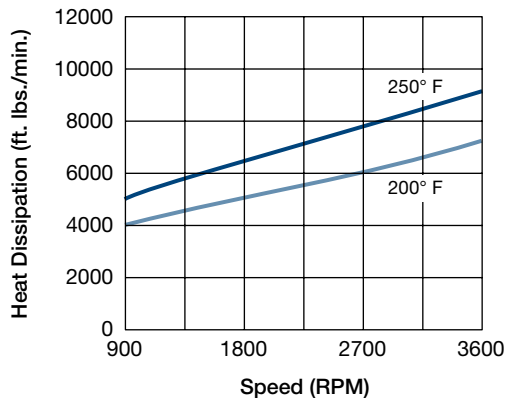

### Size 210/215

Maximum Speed 3600 RPM

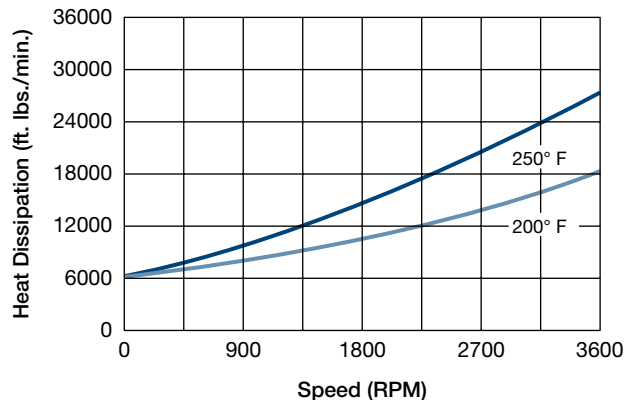



# UM-FBC Series Electrically Released NEMA C-face Brakes

## b. Torque Sizing

For most applications, the correct size clutch/brake can be selected from the Horsepower vs. Shaft Speed chart on page A-15. Determine the motor horsepower and the RPM at the clutch/brake. The correct size unit is shown at the intersection of horsepower and shaft speed.

If the static torque requirements are known, refer to the technical ratings chart to select a unit.

For some applications, the torque requirement is determined by the time allowed to accelerate and decelerate the load. (This time is generally specified in milliseconds.) For these applications, it is necessary to determine the torque requirement based on load inertia and the time allowed for engagement.

The torque requirements are calculated as follows:

$$T = (WR^2 \times N) / (308 \times t)$$

where:

T = Average Dynamic Torque (lb. ft.)

$WR^2$  = Total reflected inertia at the clutch/brake shaft. Include the clutch/brake output inertia. (lb. ft.<sup>2</sup>)

N = Speed in revolutions per minute (RPM)

t = Time allowed for the engagement (sec)

## C-face Electrically Released Brake Dynamic Torque Curves

### Size 50

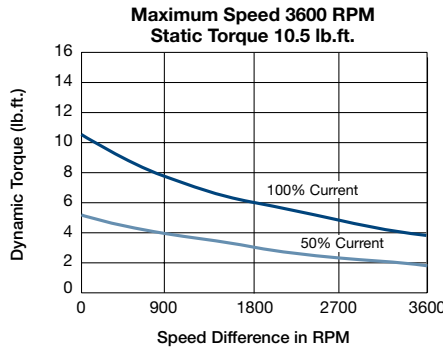

### Size 100/180

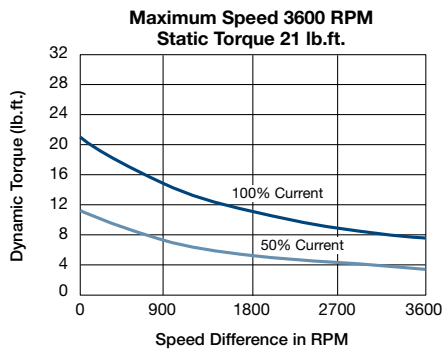

### Size 210/215

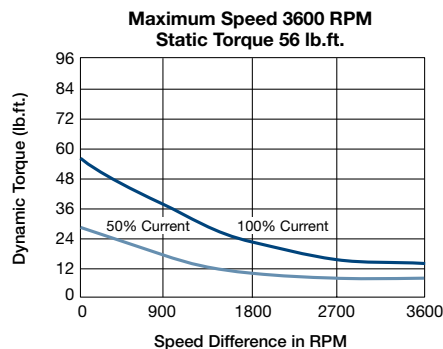

## C-face Clutch Dynamic Torque Curves

### Size 50

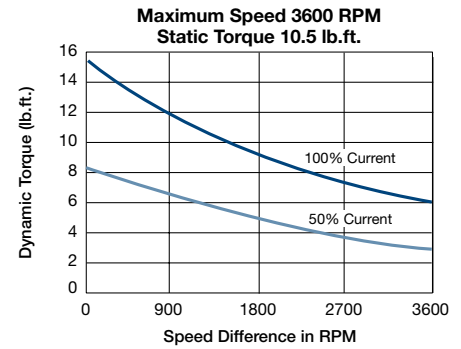

### Size 100/180

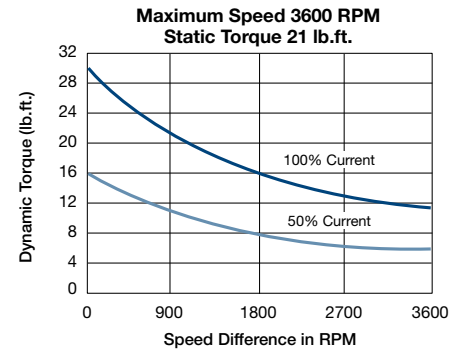

### Size 210/215

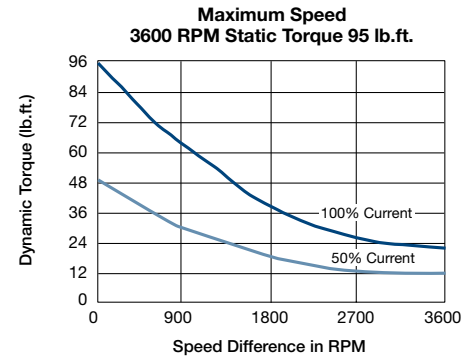

# UM-FBC Series Electrically Released NEMA C-face Brakes

## Ordering Information

### Specifications (Max. Speed 3600 RPM)

Size	Voltage DC	Weight (lbs.)		Armature		Component Inertia-WR <sup>2</sup> (lb. ft. <sup>2</sup> )					NEMA Frame Size
		1020	2030	(both)	Hub	1020		2030			
						Shaft	Rotor w/Fan and Hub	Output Shaft	Input Shaft	Rotor w/Fan and Hub	
50	24	15.6	18.4	.018	.001	.001	.020	.001	.001	.020	56C/48Y
	90										
100	24	18.7	21.7	.046	.002	.002	.046	.002	.002	.046	56C/48Y
	90										
180	24	18.7	21.7	.046	.002	.002	.046	.002	.002	.046	182C/143TC
	90										
210	24	36	47	.162	.016	.014	.190	.016	.015	.183	213C/182TC
	90										
215	24	37	48	.162	.016	.016	.190	.017	.016	.183	213TC/215TC
	90										

### 3. Select Options

Warner Electric Enclosed UniModules can be fitted with several accessories to extend their capacity and ease of mounting.

### Part Numbers

Model No.	Voltage DC	Part No.
<b>Motor Clutch/ ER Brake</b>		
UM-50-1020FBC	24	5370-273-243
UM-50-1020FBC	90	5370-273-244
UM-100-1020FBC	24	5370-273-248
UM-100-1020FBC	90	5370-273-249
UM-180-1020FBC	24	5370-273-253
UM-180-1020FBC	90	5370-273-254
UM-210-1020FBC	24	5371-273-013
UM-210-1020FBC	90	5371-273-012
UM-215-1020FBC	24	5371-273-099
UM-215-1020FBC	90	5371-273-079
<b>Input Clutch/ ER Brake</b>		
UM-50-2030FBC	24	5370-273-258
UM-50-2030FBC	90	5370-273-259
UM-100-2030FBC	24	5370-273-263
UM-100-2030FBC	90	5370-273-264
UM-180-2030FBC	24	5370-273-268
UM-180-2030FBC	90	5370-273-269
UM-210-2030FBC	24	5371-273-018
UM-210-2030FBC	90	5371-273-017
UM-215-2030FBC	24	5371-273-100
UM-215-2030FBC	90	5371-273-101

### Accessories

Description	UM Size	Part No.
Conduit Box	UM series	5370-101-042
	All sizes	
Base Mount Kit for 2030 FBC	50/100	5370-101-004
	180	5370-101-002
	210/215	5371-101-019
Motor Mount Kit for 1020 FBC	50/100	5370-101-078
	180	5370-101-079
	210/215	5371-101-012
Cover Kit	50/100/180	5370-101-076

### 4. Select Control

All electrically released modules require a control with a potentiometer that will vary brake channel output. UM-FBC units require either a CBC-300 or a CBC 500/550 control.

### How to Order

1. Specify model number and voltage or the corresponding part number.
2. Specify conduit box, if desired.
3. Specify required control unit. See the Controls Section (page CLT-1).

### Ordering Example

UM-50-1020FBC, 90V or 5370-273-244; 5370-101-042 conduit box; CBC-300 control.

# UM-FBC Series Electrically Released NEMA C-face Brakes

## UM-1020 FBC Motor Clutch/Electrically Released Brake

### SIZE 50/100/180

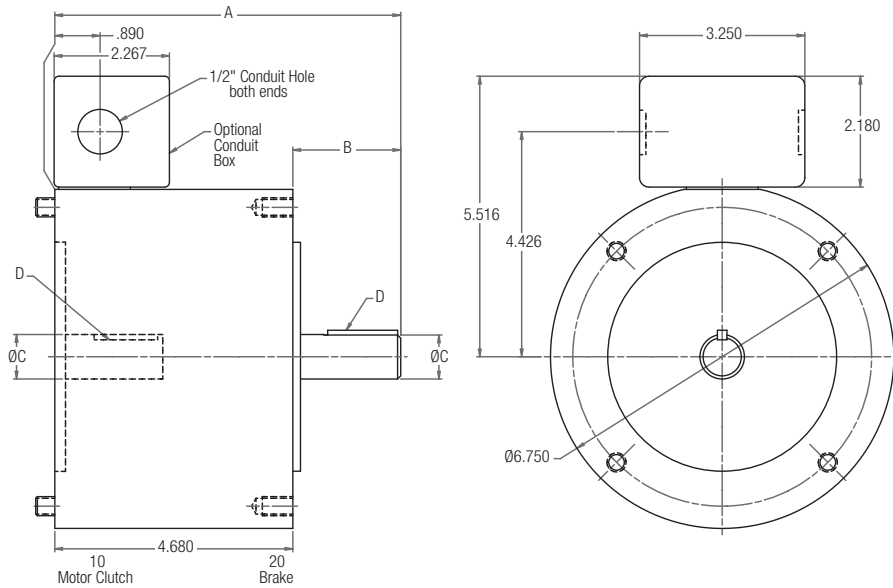

### SIZE 210/215

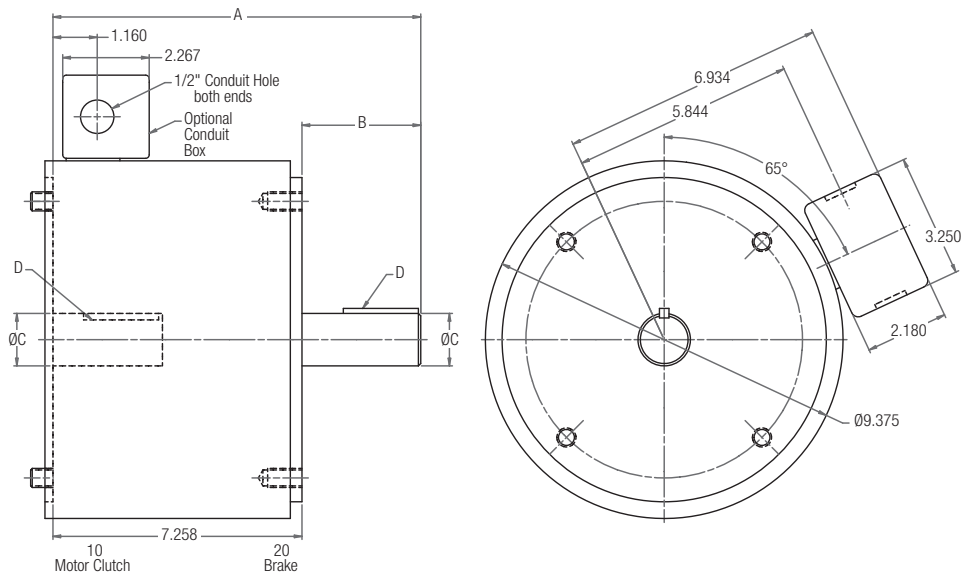

### Dimensions

Size	A	B	C	D
50	6.720	2.040	0.625	3/16 x 3/16
100	6.741	2.061	0.625	3/16 x 3/16
180	6.801	2.121	0.875	3/16 x 3/16
210	9.872	2.614	1.125	1/4 x 1/4
215	10.372	3.114	1.375	5/16 x 5/16

For standard NEMA frame dimensions, see page G-3.

### Motor Mount (M) Dimensions

For use with 1020 FBC Combination.

Size	R	S	T	U	V	W	Part No.
50/100	9.250	8.250	10.500	8.000	3.500	.800 x .406	5370-101-078
180	9.250	8.250	10.500	8.000	4.500	.800 x .406	5370-101-079
210/215	11.500	10.500	12.000	9.000	5.250	.750 x .409	5371-101-012

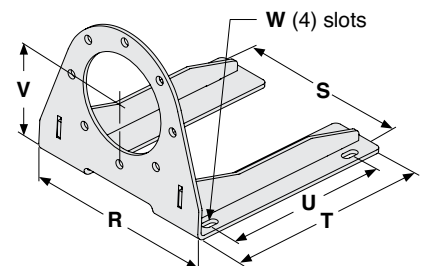

# UM-FBC Series Electrically Released NEMA C-face Brakes

## UM-2030 FBC Input Clutch/Electrically Released Brake

## UM-2030 FBC-B Input Clutch/Electrically Released Brake – Base Mounted

### SIZE 50/100/180

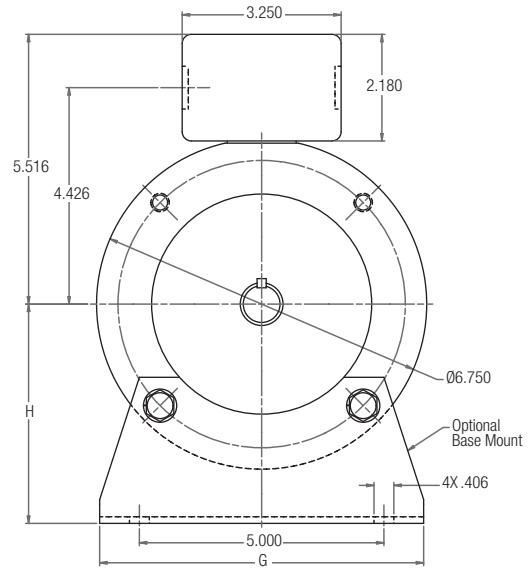
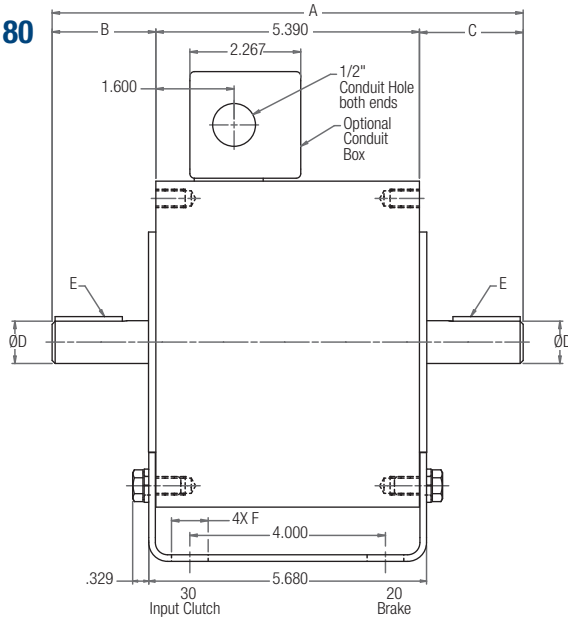

Note: Mounting base and conduit box are optional and are ordered separately.

### SIZE 210/215

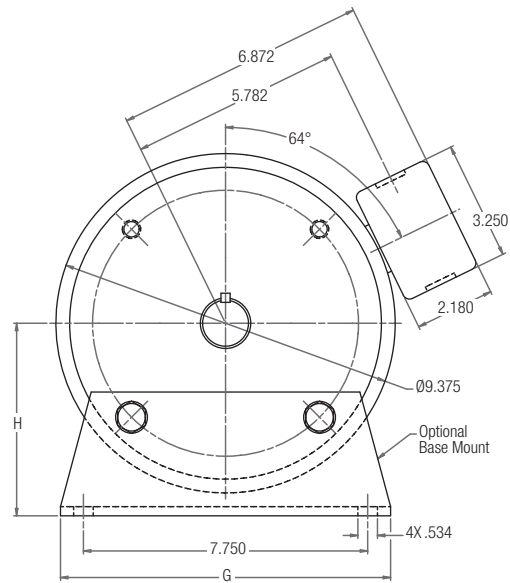
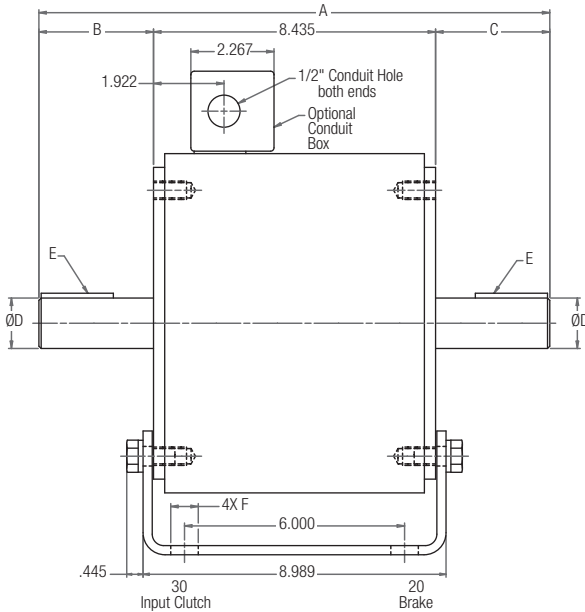

### Dimensions

Size	A	B	C	D	E	F	G	H
50	9.492	2.062	2.040	0.625	3/16 x 3/16	0.800	6.000	3.500
100	9.512	2.061	2.061	0.625	3/16 x 3/16	0.800	6.000	3.500
180	9.632	2.121	2.121	0.875	3/16 x 3/16	0.750	6.625	4.500
210	13.674	2.625	2.614	1.125	1/4 x 1/4	0.750	9.000	5.250
215	14.674	3.125	3.114	1.375	5/16 x 5/16	0.750	9.000	5.250

For standard NEMA frame dimensions, see page G-3.

# UM-FBC Series Electrically Released NEMA C-face Brakes

## Enclosing UM-FBC Series

Clean, quiet, operation. Nothing can get in, nothing can get out. Enclosed design eliminates damage to the working components. Prevents friction wear particles from escaping.

### Totally Enclosed Version

The Enclosed UniModule packages the hardworking components from UM products into a totally enclosed housing. This rugged housing keeps wear particles in and contaminants out and provides quiet operation. Pre-burnished at the factory for rated torque directly out-of-box. When enclosed, they are suitable for most industrial applications and tolerate infrequent, light washing.

- Keeps contaminants out
- Keeps wear particles in
- Quiet operation
- Finned for heat dissipation
- UL listed when optional conduit box is installed

### Heat Dissipation Curves

#### UM-50 with Cover Kit

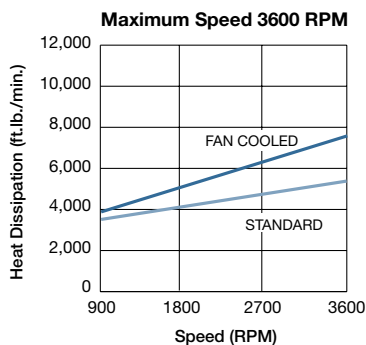

#### UM-100/180 with Cover Kit

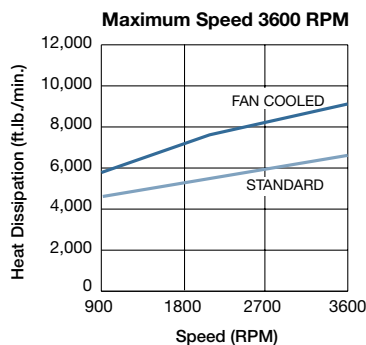

**To convert any UM Series UniModule 50, 100, and 180 sizes to an enclosed model, purchase optional Cover Kit**

### Enclosed UniModule Conversion

#### Part Number 5370-101-076

An optional cover kit can be purchased separately to enclose the open vents in the housing. Each kit contains (2) vent covers, (2) gaskets and (4) screws. A vent cover bolts to both sides of the UniModule unit to enclose the open vents of the housing creating a totally enclosed (non-washdown) brake package which keeps contaminants out and wear particles in for clean, quiet operation.



# EUM Series Electrically Released NEMA C-face Brakes

## Preassembled, Totally Enclosed, Electrically Released Brake Units

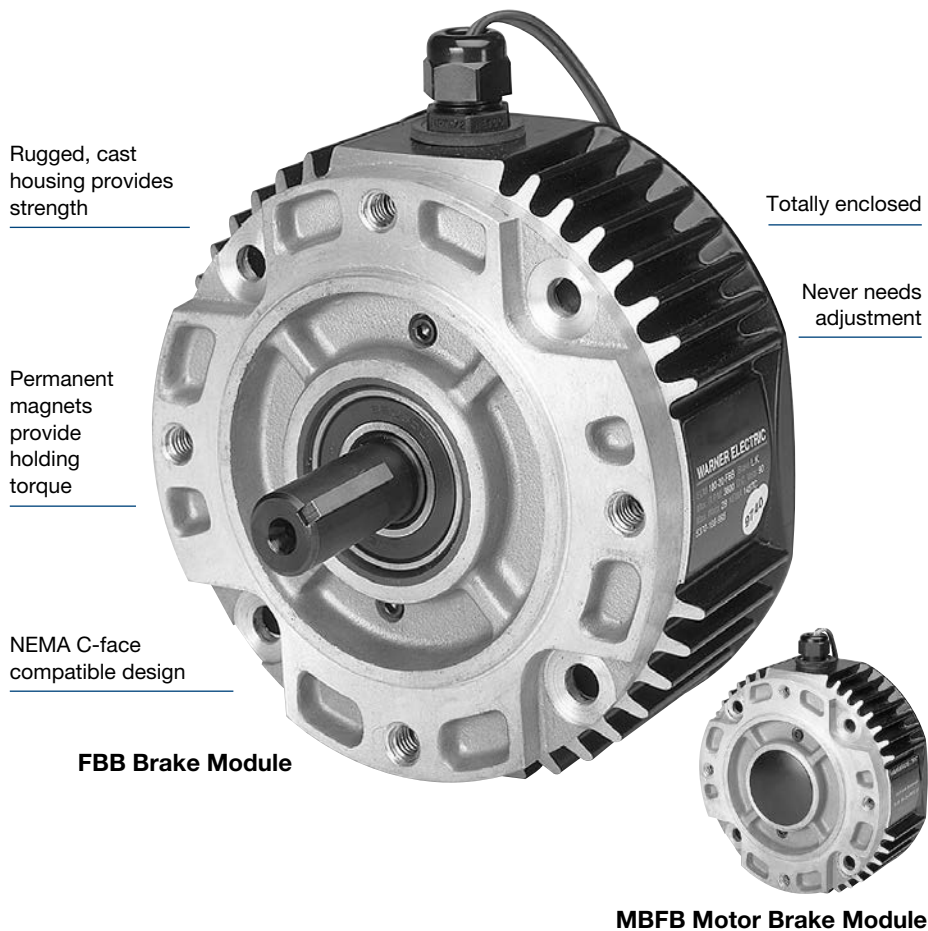

### Available in Two Design Styles

*210/215 size shown*

#### **EUM-FBB Brake Module**

Use for brake alone applications. Mounts between a motor and gear box or reducer. Available in four sizes.

#### **EUM-MBFB Motor Brake Module**

Mounts to a double shafted C-face motor. Available in five sizes.

Warner Electric offers the convenience of pre-assembly in UniModule electrically released brake packages. Assembly, alignment, and preburnishing have been done at the factory. Bolt it on, wire it up, and your electrically released brake is ready to go. (Control and conduit box optional)

Care must be exercised to assure proper sizing and selection of electrically released brakes. Motor brakes are used for dynamic stopping and holding of loads when power is removed from the motor. Typical applications include conveyors, process equipment, and lifting devices.

Warner Electric brakes are designed for NEMA C-face motors which match the motor frame size and shaft diameter to the brake. To select a brake, determine the motor frame size and pick an MBFB for double shafted motors or an FBB for mounting between a motor and a gear reducer. Select the torque required for the

application. Higher torque brakes stop loads faster. Lower torque models provide softer stopping to prevent boxes on conveyors from tipping or skidding.

They are sized to provide nominal stopping of a motor in the event of power loss. If your application requires true "Fail safe" braking, the brake must be sized to meet or exceed peak motor torque and placed as close to the load shaft as possible. Peak motor torque can be determined by the formula:

$$\text{Peak Torque} = \frac{(\text{HP} \times 5250)}{\text{Motor Speed}}$$



# EUM Series Electrically Released NEMA C-face Brakes

## EUM-FBB, EUM-MBFB Selection

Warner Electric Electrically Released Enclosed UniModules are available in two styles. The EUM-FBB Brake Module is used in brake only applications and mounts between a C-face motor and a gear box or reducer. The EUM-MBFB Motor Brake Module mounts to the back of a double shafted motor.

Note: Care must be exercised when selecting a brake to ensure it is sized properly for your application.

### 1. Select Configuration

#### a. FBB for NEMA C-face Mounting Between a Motor and Reducer

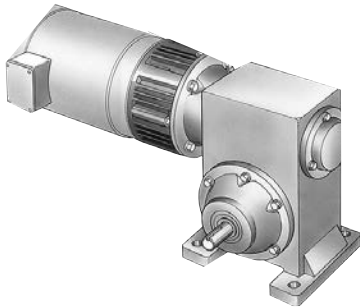

Verify that the brake will be cycled frequently.

Determine the NEMA C-face frame size of your motor and/or reducer, and choose the corresponding size Enclosed UniModule from the Frame Size Selection chart.

Size EUM-100 modules utilize a 5/8" diameter shaft to fit 56C/48Y motor frames with components of EUM-180 units for higher torque and heat dissipation capacity than the EUM-50.

#### EUM-FBB Frame Size Selection

NEMA Frame Size	EUMSize
56C/48Y	EUM-50* EUM-100**
182C/143TC 184C/145TC	EUM-180
213C/182TC 215C/184TC	EUM-210
213TC/215TC	EUM-215

\*For 56C/48Y C-frame motors 3/4 HP and smaller, the EUM-100 size may be used where extended life is desirable.

\*\*The EUM-100 size is recommended for motors 1 HP and larger.

#### b. MBFB for NEMA C-face Mounting on the Back of a Double Shafted Motor

Verify that the brake will be cycled frequently.

Determine the NEMA C-face frame size of your motor and/or reducer, and choose the corresponding size Enclosed UniModule MBFB from the Frame Size Selection chart, and verify that the motor shaft diameter and mounting bolt circle are the same for the brake and the motor.

Size EUM-100 modules utilize a 5/8" diameter shaft to fit 56C/48Y motor frames with components of EUM-180 units for higher torque and heat dissipation capacity than the EUM-50.

#### EUM-MBFB Frame Size Selection

NEMA Frame Size	EUM Brake Size	Bolt Hole Mounting Circle	Motor Shaft Dia.
56C/48Y	EUM-50* EUM-100**	5.875	0.625
182C/143TC 184C/145TC	EUM-180	5.875	0.875
213C/182TC 215C/184TC	EUM-210-7/8 EUM-210	7.25 7.25	0.875 1.125

\*For 56C/48Y C-frame motors 3/4 HP and smaller, the EUM-100 size may be used where extended life is desirable.

\*\*The EUM-100 size is recommended for motors 1 HP and larger.

#### Horsepower vs. Shaft Speed

HP	SHAFT SPEED AT CLUTCH (IN RPM)																	
	100	200	300	400	500	600	700	800	900	1000	1100	1200	1500	1800	2000	2400	3000	3600
1/4	■																	
1/2	■	■																
3/4	■	■	■															
1	■	■	■	■														
1-1/2	■	■	■	■	■													
2	■	■	■	■	■	■												
3	■	■	■	■	■	■	■											
5	■	■	■	■	■	■	■	■										
7-1/2	■	■	■	■	■	■	■	■	■									
10	■	■	■	■	■	■	■	■	■	■								

\*For applications with speeds below 100RPM, please contact Warner Electric Application Support.

# EUM Series Electrically Released NEMA C-face Brakes

## a. Heat Dissipation Sizing

Friction surfaces slip during the initial period of engagement and, as a result, heat is generated. The clutch/brake selected must have a heat dissipation rating greater than the heat generated by the application. Therefore, in high inertia or high cycle rate applications, it is necessary to check the heat dissipation carefully. Inertia, speed and cycle rate are the required parameters.

Heat dissipation requirement is calculated as follows:

$$E = 1.7 \times WR^2 \times (N/100)^2 \times F$$

where:

$$E = \text{Heat (lb. ft./min.)}$$

$WR^2$  = Total reflected inertia at the clutch/brake shaft. Include the clutch/brake output inertia. (lb.ft.<sup>2</sup>)

N = Speed in revolutions per minute. (RPM)

F = Cycle rate in cycles per minute (CPM)

Compare the calculated heat generated in the application to the unit ratings using the heat dissipation curves. Select the appropriate unit that has adequate heat dissipation ability.

## Heat Dissipation Curves

### Size 50

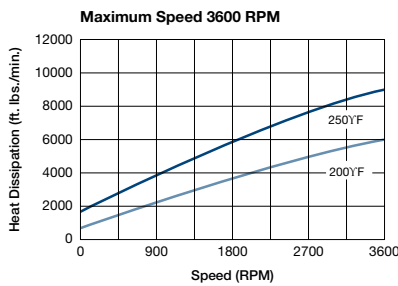

### Size 100/180

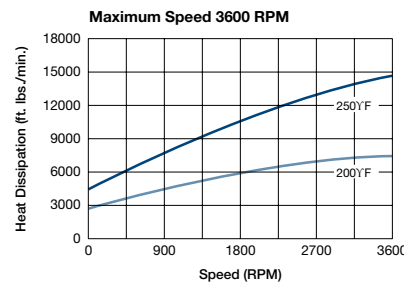

### EUM 210/215 (fan not available for 215)

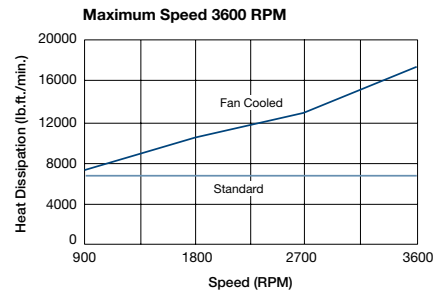

## b. Torque Sizing

For most applications, the correct size clutch/brake can be selected from the Horsepower vs. Shaft Speed chart on page A-23. Determine the motor horsepower and the RPM at the clutch/brake. The correct size unit is shown at the intersection of horsepower and shaft speed.

If the static torque requirements are known, refer to the technical ratings chart to select a unit.

For some applications, the torque requirement is determined by the time allowed to accelerate and decelerate the load. (This time is generally specified in milliseconds.) For these applications, it is necessary to determine the torque requirement based on load inertia and the time allowed for engagement.

The torque requirements are calculated as follows:

$$T = (WR^2 \times N) / (308 \times t)$$

where:

T = Average Dynamic Torque (lb. ft.)

$WR^2$  = Total reflected inertia at the clutch/brake shaft. Include the clutch/brake output inertia. (lb. ft.<sup>2</sup>)

N = Speed in revolutions per minute. (RPM)

t = Time allowed for the engagement (sec)

## C-face Electrically Released Brakes Dynamic Torque Curves

### Size 50

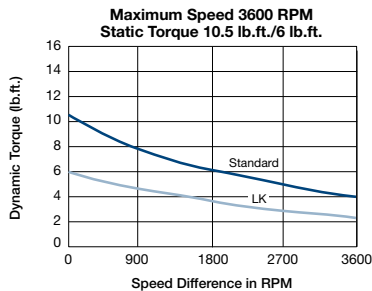

### Size 100/180

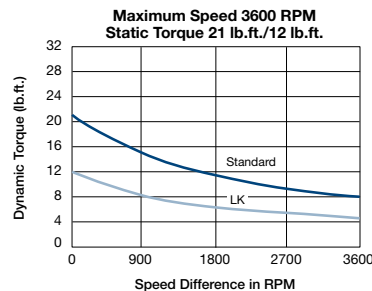

### Size 210/215

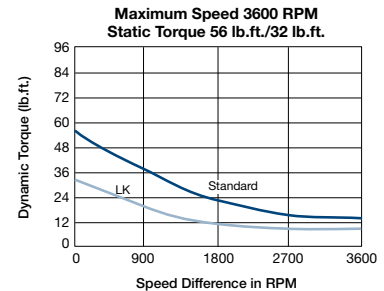

# EUM Series Electrically Released NEMA C-face Brakes

## Preassembled, Totally Enclosed, Electrically Released Brake Units

### Specifications

Size	Voltage DC	Static Torque (lb.ft.)	Max. Speed (RPM)	Total Weight (lbs.)	Armature (lb.ft. <sup>2</sup> )	Component Inertia -WR <sup>2</sup> (lb.ft. <sup>2</sup> )				
						FBB		MBFB		NEMA Frame Size
						Hub (lb. ft.2)	Shaft (lb.ft.2)	Hub Spliced	Shaft Input	
50	24, 90	6, 10.5	3600	8.6	.009	.001	.0005	.001	.0003	56C/48Y
100	24, 90	12, 21	3600	10.5	.023	.002	.002	.002	.002	56C/48Y
180	24, 90	12, 21	3600	10.5	.023	.002	.002	.002	.002	182C/143TC 184C/145TC
210	90	32, 56	3600	27	.081	.016	.021	.016	.007	213C/182TC 215C/184TC
215	90	32, 56	3600	27	.081	.016	.022	N/A	N/A	213TC/215TC

### 3. Select Options

Warner Electric Enclosed UniModules can be fitted with several accessories to extend their capacity and ease of mounting.

### 4. Select Control

All electrically released modules require a control with a potentiometer that will vary brake channel output. For FBB and MBFB brake modules, the CBC-160, CBC-300, or CBC-500/550 is recommended. The FBC units require either a CBC-300 or a CBC 500/550 control.

# EUM Series Electrically Released NEMA C-face Brakes

## Selection/Ordering Information

### Selection Procedure

Note: Care must be exercised when selecting the proper brake size for your application.

The selection charts list NEMA motor frame sizes, motor shaft diameters, and the matching FBB or MBFB brakes.

To select a brake:

- Determine the motor NEMA C-face frame size.
- Select brake configuration
  - FBB to mount between a NEMA C-face motor and a gear reducer.
  - MBFB to mount on double shafted NEMA C-face motors.
- Select the brake model from the charts by the torque required - higher torque for faster stopping, lower torque for longer "soft" stopping, Ref: LK Facing. Note: LK facing is only available in 24 volts as a special - contact technical support for assistance.

Note: Size 100 brakes are typically used on motors with a rating of 1 HP or greater.

- Important:** Verify that the motor shaft diameter and mounting bolt circle dimensions are the same for the brake selected and the motor.

### Control Selection

An optional conduit box enclosure is available. All electrically released units require a control with a potentiometer to vary brake channel output. For FBB and MBFB brake modules, control models CBC-160, CBC-300, or CBC-500/550 are recommended. (See Controls Section.)

### How to Order

- Specify model number and voltage or the corresponding part number.
- Specify conduit box, if desired. See the Controls Section.
- Specify required control unit. See the Controls Section.

### Ordering Example

EUM-50-20FBB-6, 90V or 5370-169-983; 5370-101-042 conduit box; CBC-160-2 control.

Totally Enclosed EUM Model No.	Voltage D.C.	COMBINED Part Numbers		OR	SEPARATE Part Numbers	
		UniModule w/kit			UniModule	and Cover Kit
<b>20 FBB Brake Module - Standard Facing</b>						
EUM-50-20FBB-10	24	N/A			5370-169-278 and 5370-101-082	
EUM-50-20FBB-10	90	5370-32			5370-169-279 and 5370-101-082	
EUM-100-20FBB-21	24	N/A			5370-169-283 and 5370-101-082	
EUM-100-20FBB-21	90	5370-33			5370-169-284 and 5370-101-082	
EUM-180-20FBB-21	24	N/A			5370-169-288 and 5370-101-082	
EUM-180-20FBB-21	90	5370-34			5370-169-289 and 5370-101-082	
EUM-210-20FBB-56	90	5371-169-082			N/A	
EUM-215-20FBB-56	90	5371-169-090			N/A	
<b>20 FBB Brake Module - LK Facing</b>						
EUM-50-20FBB-6	90	5370-169-260			N/A	
EUM-100-20FBB-12	90	5370-169-261			N/A	
EUM-180-20FBB-12	90	5370-169-262			N/A	
EUM-210-20FBB-32	90	5371-169-078			N/A	
EUM-215-20FBB-32	90	5371-169-086			N/A	
<b>20 MBFB Motor Brake Module - Standard Facing</b>						
EUM-50-20MBFB-10	24	N/A			5370-169-248 and 5370-101-082	
EUM-50-20MBFB-10	90	5370-35			5370-169-249 and 5370-101-082	
EUM-100-20MBFB-21	24	N/A			5370-169-253 and 5370-101-082	
EUM-100-20MBFB-21	90	5370-36			5370-169-254 and 5370-101-082	
EUM-180-20MBFB-21	24	N/A			5370-169-258 and 5370-101-082	
EUM-180-20MBFB-21	90	5370-37			5370-169-259 and 5370-101-082	
EUM-210-7/8-20MBFB-56	90	5371-169-068			N/A	
EUM-210-20MBFB-56	90	5371-169-060			N/A	
<b>20 MBFB Motor Brake Module- LK Facing</b>						
EUM-50-20MBFB-6	90	5370-169-263			N/A	
EUM-100-20MBFB-12	90	5370-169-264			N/A	
EUM-180-20MBFB-12	90	5370-169-265			N/A	
EUM-210-7/8-20MBFB-32	90	5371-169-064			N/A	
EUM-210-20MBFB-32	90	5371-169-056			N/A	

### Accessories

Description	FBB Size	Part No.
Conduit Box	FBB series All sizes	5370-101-042
Motor Mount Kit for 20 FBB	50/100/180 210/215	5370-101-079 5371-101-012

# EUM-FBB Series Electrically NEMA C-face Released Brakes

## EUM-FBB Brake Module

### SIZE 50/100/180

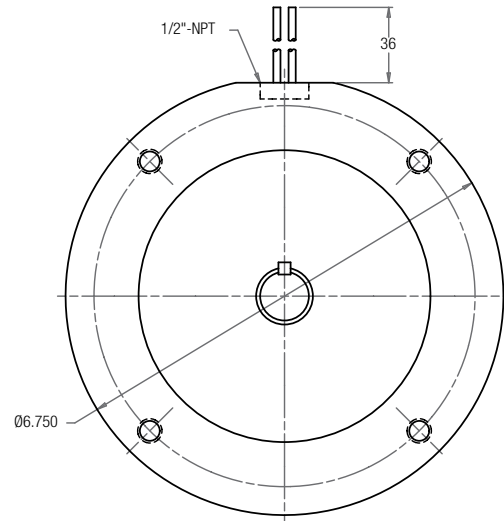
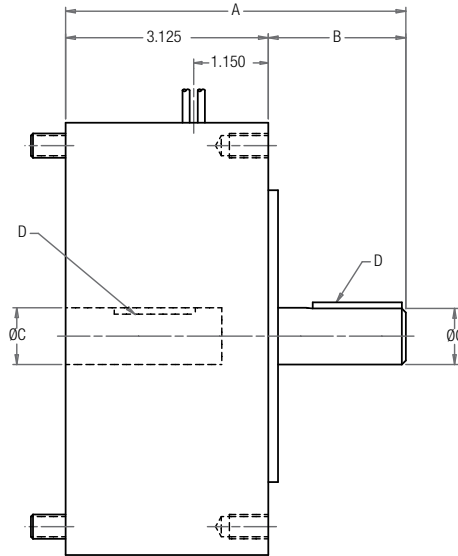

### SIZE 210/215

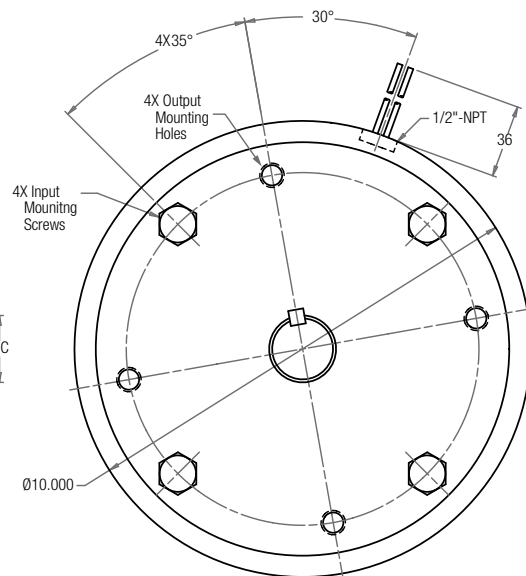
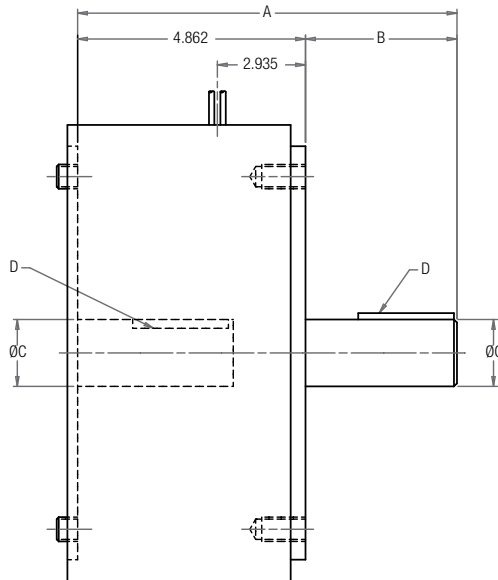

### Dimensions

Size	A	B	C	D
50	5.165	2.040	0.625	3/16 x 3/16
100	5.186	2.061	0.625	3/16 x 3/16
180	5.246	2.121	0.875	3/16 x 3/16
210	7.476	2.614	1.125	1/4 x 1/4
215	7.976	3.114	1.375	5/16 x 5/16

For standard NEMA frame dimensions, see page G-3.

# EUM-MBFB Series Electrically Released NEMA C-face Brakes

## EUM-MBFB Motor Brake Module

### SIZE 50/180

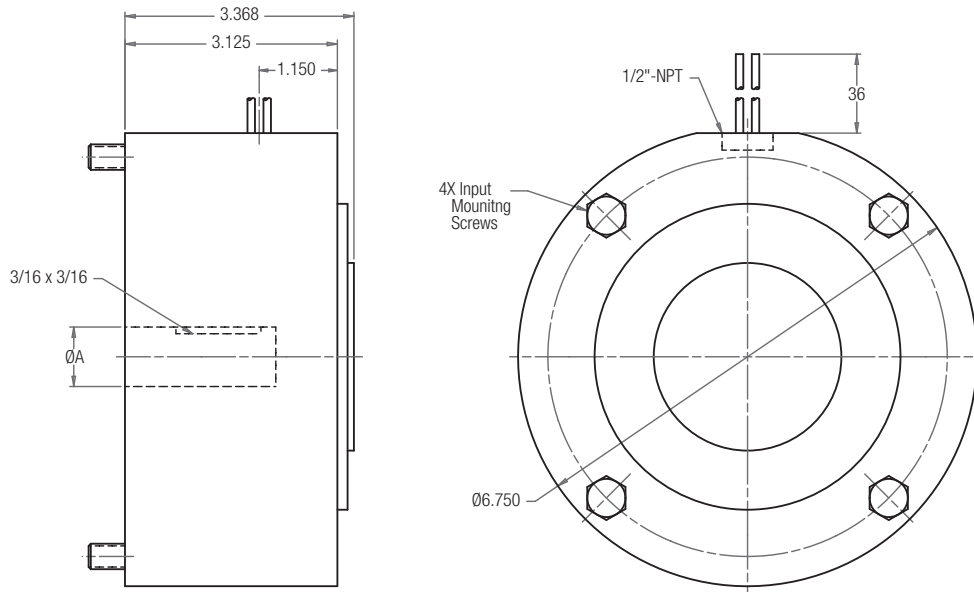

### SIZE 210

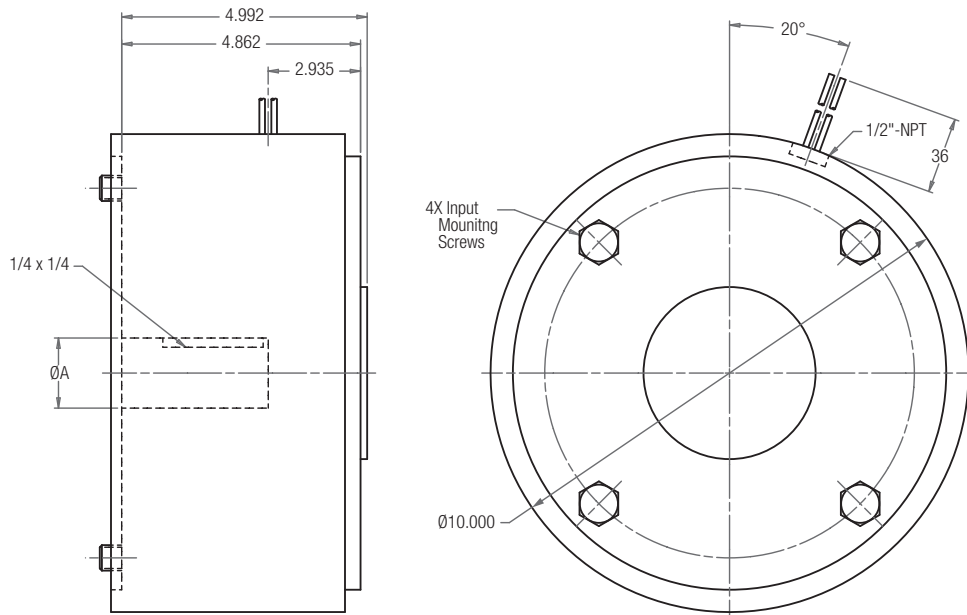

### Dimensions

Size	A
50	0.625
180	0.875
210	1.125

For standard NEMA frame dimensions, see page G-3.



# EM Series Electrically Released NEMA C-face Brakes

## Electro Module, Electrically Released Brakes and Clutch/Brake Units for Dynamic Stopping and Cycling Applications

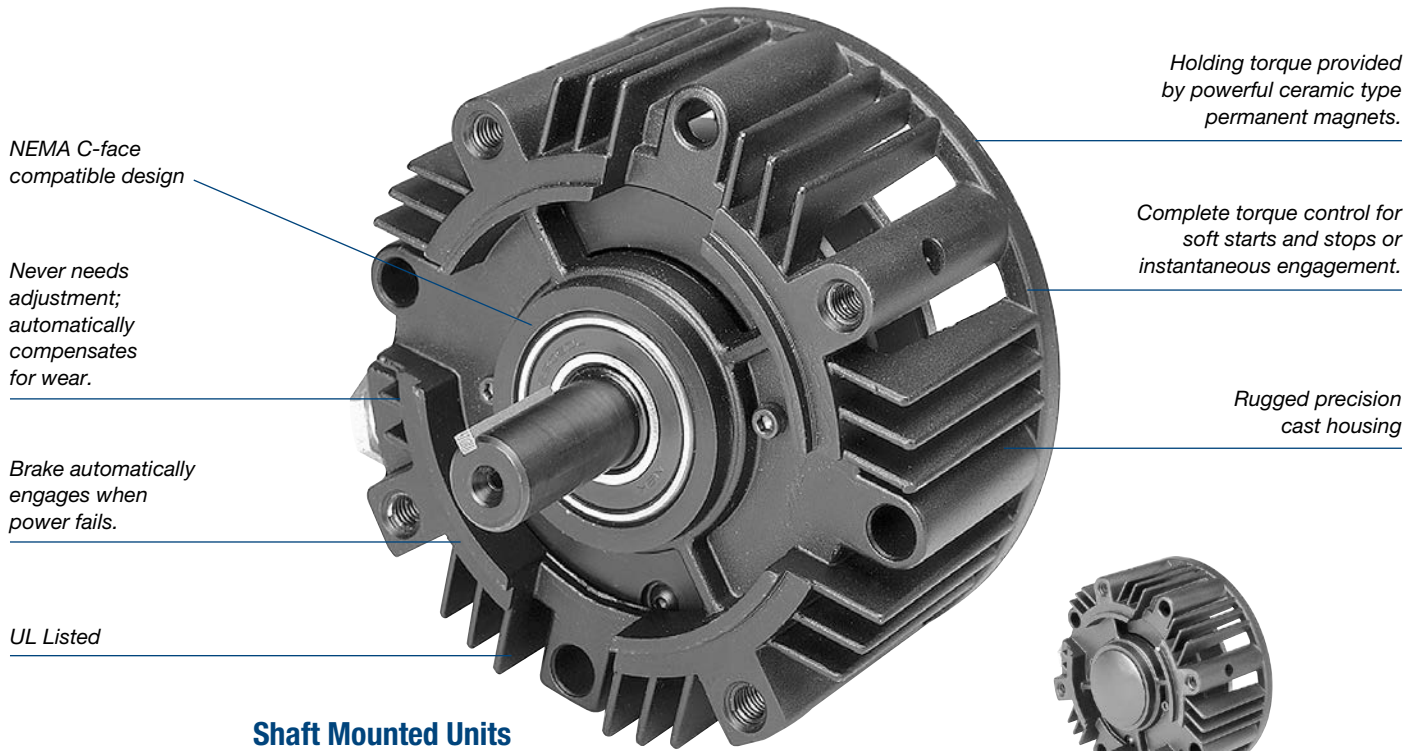

NEMA C-face compatible design

Never needs adjustment; automatically compensates for wear.

Brake automatically engages when power fails.

UL Listed

Holding torque provided by powerful ceramic type permanent magnets.

Complete torque control for soft starts and stops or instantaneous engagement.

Rugged precision cast housing

### Shaft Mounted Units

**FBB Brake Module**

**FBC Brake Module for use with a clutch**

**MBFB Motor Brake Module**

*210/215 size shown*

Warner Electric's unique design employs powerful permanent magnets for maximum torque when power is removed from the brake coil. A small amount of electrical power applied to the brake coil nullifies the permanent magnets' force and the brake releases. No springs to limit cycle rates. Never need adjustment. No lubrication. These brakes are recommended for dynamic cycling operations only.

### Available in Three Design Styles

#### EM-FBB Brake Module

Use for brake alone applications. Mounts between a C-face motor and a gear box or reducer. Available in five sizes.

#### EM-MBFB Motor Brake Module

Mounts to the back of a double shafted motor. Available in four sizes.

#### EM-FBC Brake Module for use with a Clutch

Combine with a motor or input clutch for clutch/brake applications. Three sizes are available.

### Specifications

Size	Voltage DC	Static Torque (lb.ft.)		Max. Speed (RPM)	Total Weight (lbs.)	Component Inertia - WR <sup>2</sup> (lb.ft. <sup>2</sup> )				NEMA Frame Size
		Brake	Clutch			Armature		Hub	Shaft	
EM-50	24	10.5	16	3600	8.6	.0071	.014	.003	.001	56C/48Y
	90									
EM-100	90	21	—	3600	10.5	.018	—	.004	.002	56C/48Y
	24									
EM-180	24	21	30	3600	10.5	.018	.036	.004	.002	182C/143TC
	90									
EM-210	24	56	95	3600	27	.081	.162	.027	.017	213C/182TC
	90									
										215C/184TC

# EM Series Electrically Released NEMA C-face Brakes

## For Dynamic Stopping and Cycling Applications

Warner Electric's modular design brakes and clutch/brake units offer material handling system users a high performance alternative to spring-set brakes. These modular units provide long life, maintenance free operation, and consistent performance with minimal downtime.

These brakes are offered in power-off types for double shaft motors and for installation between C-face motor and reducer or other drive device. Powerful permanent magnets generate braking torque. The brakes release when voltage is applied to the coil, countering the force of the permanent magnets. No power is required to stop or hold a load. An optional integral conduit box provides simple wiring direct from the motor power leads.

- Designed for dynamic stopping operations
- Brake automatically engages when power is turned off
- High cycle rate capability
- Never needs adjustment – automatically compensates for wear
- Powerful permanent magnets provide braking force
- Choice of open or enclosed brakes
- Prepackaged, preburnished UM version

### Three C-face Compatible Designs

The UM Series (UniModule Clutch/Brakes) are preassembled clutch/electrically released brake modules.

- The UM-1020-FBC brake/motor clutch combination is used for clutch/power-off brake applications. It mounts directly to C-face compatible components.
- The UM-2030-FBC brake/input clutch combination is used for clutch/power-off brake applications. It has shafts on both the input and output sides for base mounting.

The EUM Series (Enclosed Motor Brakes) are totally enclosed non-vented units that keep wear particles in and contaminants out.

- The EUM-FBB brake unit can be mounted between two C-face compatible components.
- The EUM-MBFB motor brake is mounted directly to the rear of a double-shafted motor.

The EM Series (Electro Module Brakes and Clutch/Brakes) are comprised of individual units that may bolt together to form various combinations:

- The EM-FBB brake module mounts between a C-face motor and a gear box or reducer.
- The EM-MBFB motor brake module is mounted to the rear of a double-shafted motor.
- The EM-FBC brake module is used in combination with a motor clutch or input clutch unit to make a clutch/electrically released brake or can be used alone as a brake only.

### Brake Modules (FBB)

For mounting between a C-face motor and a gearbox or reducer

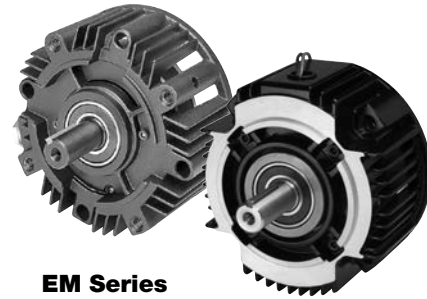

**EM Series  
Shaft mounted,  
vented housing**

Use for brake alone applications.

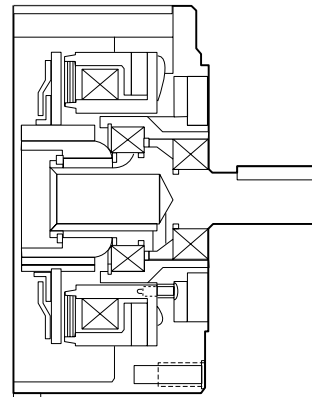

### Features

- Single armature for brake alone applications
- Output shaft
- Permanent magnets
- UL listed

### **EM-FBB**

Available in 5 sizes

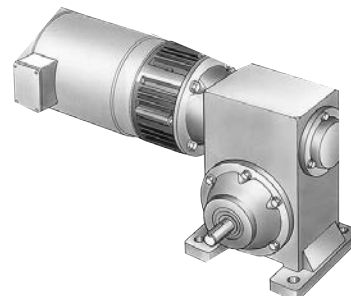

EM-FBB Electro Module brake unit between a motor and a reducer.

# EM Series Electrically Released NEMA C-face Brakes

## C-face Compatible Brakes and Clutch/Brakes

### Motor Brake Modules (MBFB)

For mounting directly to the rear of a double-shafted motor



**EM Series vented housing**

Use as a motor brake on C-face type motors.

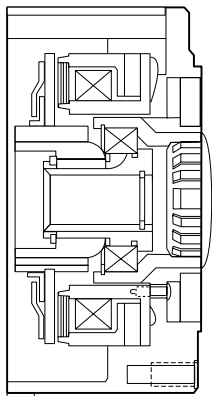

#### Features

- Single armature design
- Complete torque control
- Precision cast housing
- Ceramic type permanent magnets

#### EM-MBFB

Available in 5 sizes

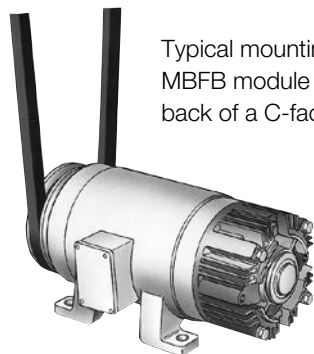

Typical mounting of an MBFB module on the back of a C-face motor

### Clutch/Brake Modules (FBC)

Clutch/Fail-safe brake for mounting between a C-face motor and a gearbox or reducer



**EM Series Modular unit with C/B capability**

Combine with a motor or input clutch for clutch/brake applications or use alone as a brake only.

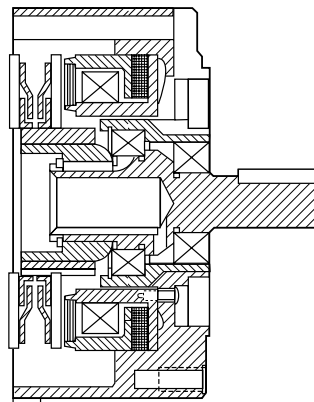

#### Features

- Dual armature for clutch/brake combination
- Output shaft
- Can be base mounted for use as a separate drive unit.

#### EM-FBC

Available in 4 sizes

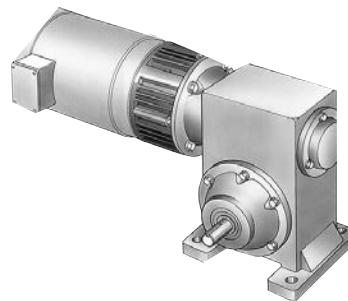

EM-FBC Electro Module brake unit combined with a motor clutch module

EM-FBC UniModule clutch/brake mounted on a base

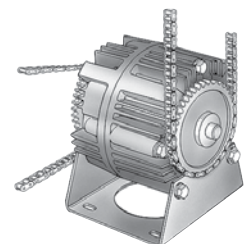

# EM Series Electrically Released NEMA C-face Brakes

## EM-FBB, EM-FBC, EM-MBFB Selection

Warner Electric Electrically Released Electro Modules are available in three styles. The EM-FBB Brake Module is used in brake only applications and mounts between a C-face motor and a gear box or reducer. The EM-MBFB Motor Brake Module mounts to the back of a double shafted motor. The EM-FBC Brake Module is combined with a motor clutch (EM-10) or an input clutch (EM-30) for clutch/electrically released brake applications.

Note: Care must be exercised when selecting a brake to ensure it is sized properly for your application.

### 1. Select Configuration

#### a. For FBB and MBFB Modules NEMA C-face Mounting

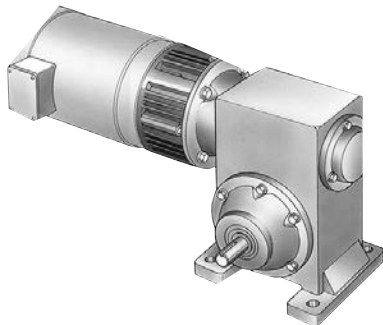

Verify that the brake will be cycled frequently.

Determine the NEMA C-face frame size of your motor and/or reducer, and choose the corresponding size Electro Module from the Frame Size Selection chart.

Size EM-100 modules utilize a 5/8" diameter shaft to fit 56C/48Y motor frames with components of EM-180 units for higher torque and heat dissipation capacity than the EM-50.

Select Brake Configuration: use an EM-FBB for mounting between a motor and a reducer; or an EM-MBFB for mounting on the rear of a double shafted motor.

NOTE: When selecting an MBFB, ensure the shaft dimensions on the rear of the motor are compatible with the EM-MBFB unit selected.

#### b. For FBC Modular Units, NEMA C-face Mounting

Verify that brake will be cycled frequently, and will be used with a motor mounted clutch (EM-10) for C-face mounting.

Determine the NEMA C-face frame size of your motor and/or reducer, and choose the corresponding size Electro Module from the Frame Size Selection chart.

### FBC Frame Size Selection

NEMA Frame Size	EM Size
56C/48Y	EM-50* EM-100**
182C/143TC	EM-180
184C/145TC	
213C/182TC	EM-210
215C/184TC	

For torque ratings, refer to the "Specifications" chart. Note that separate torque ratings are listed for the clutch and brake segments of the module.

\* For 56C/48Y C-frame motors 3/4 HP and smaller, the EM-100 size may be used where extended life is desirable.

\*\* The EM-100 size is recommended for motors 1 HP and larger.

#### c. For FBC Modular Units, Base Mounting

Verify that brake will be cycled

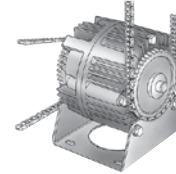

frequently, and will be used with an input clutch (EM-30) for base mounting.

Select the correct size module from the Horsepower vs. Shaft Speed chart (at the bottom of this page) by determining the motor horsepower and RPM at the module location. The correct size EM is shown at the intersection of the HP and operating speed. For additional sizing information, refer to the technical sizing procedure (step 2).

### FBB and MBFB Frame Size Selection

NEMA Frame Size	EM Size
56C/48Y	EM-50* EM-100**
182C/143TC	EM-180
184C/145TC	
213C/182TC	EM-210
215C/184TC	
213TC/215TC	EM-215

\*For 56C/48Y C-frame motors 3/4 HP and smaller, the EM-100 size may be used where extended life is desirable.

\*\*The EM-100 size is recommended for motors 1 HP and larger.

### Horsepower vs. Shaft Speed

HP	SHAFT SPEED AT CLUTCH (IN RPM)																		
	100	200	300	400	500	600	700	800	900	1000	1100	1200	1500	1800	2000	2400	3000	3600	
1/4																			
1/2														EM-50					
3/4																			
1																			
1-1/2														EM-100 or EM-180					
2																			
3																			
5																			
7-1/2																			

\*For applications with speeds below 100RPM, please contact Warner Electric Application Support.

# EM Series Electrically Released NEMA C-face Brakes

## 2. Determine Technical Requirements

Technical considerations for sizing and selection are torque and heat dissipation. Each merits careful consideration, especially heat dissipation as over time, use in excessive temperature environments will have an adverse effect on bearing life and coil wire insulation integrity.

Compare the calculated torque requirement with the average dynamic torque ratings. Select a unit with adequate torque. If the unit selected on torque is different than the unit selected based on heat, select the larger size unit.

### a. Heat Dissipation Sizing

Friction surfaces slip during the initial period of engagement and, as a result, heat is generated. The clutch/brake selected must have a heat dissipation rating greater than the heat generated by the application. Therefore, in high inertia or high cycle rate applications, it is necessary to check the heat dissipation carefully. Inertia, speed and cycle rate are the required parameters.

Heat dissipation requirement is calculated as follows:

$$E = 1.7 \times WR^2 \times (N/100)^2 \times F$$

where:

$$E = \text{Heat (lb. ft./min.)}$$

$WR^2$  = Total reflected inertia at the clutch/brake shaft. Include the clutch/brake output inertia. (lb.ft.<sup>2</sup>)

N = Speed in revolutions per minute. (RPM)

F = Cycle rate in cycles per minute (CPM)

Compare the calculated heat generated in the application to the unit ratings using the heat dissipation curves. Select the appropriate unit that has adequate heat dissipation ability.

## Heat Dissipation Curves

### Size 50

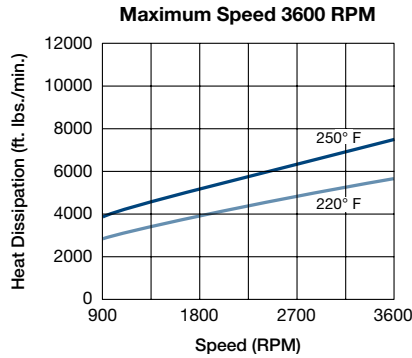

### Size 100/180

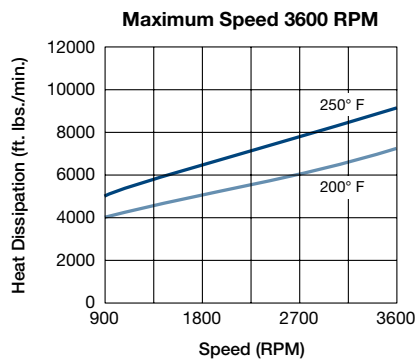

### Size 210/215

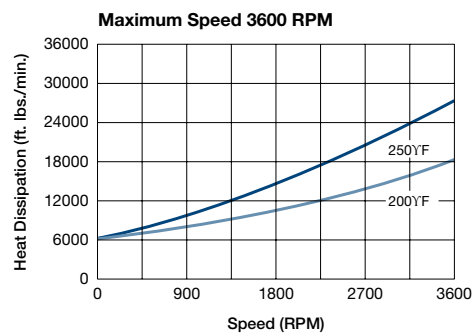

### b. Torque Sizing

For most applications, the correct size clutch/brake can be selected from the Horsepower vs. Shaft Speed chart on page A-32. Determine the motor horsepower and the RPM at the clutch/brake. The correct size unit is shown at the intersection of horsepower and shaft speed.

If the static torque requirements are known, refer to the technical ratings chart to select a unit.

For some applications, the torque requirement is determined by the time allowed to accelerate and decelerate the load. (This time is generally specified in milliseconds.) For these applications, it is necessary to determine the torque requirement based on load inertia and the time allowed for engagement.

The torque requirements are calculated as follows:

$$T = (WR^2 \times N) / (308 \times t)$$

where:

T = Average Dynamic Torque (lb. ft.)

$WR^2$  = Total reflected inertia at the clutch/brake shaft. Include the clutch/brake output inertia. (lb. ft.<sup>2</sup>)

N = Speed in revolutions per minute (RPM)

t = Time allowed for the engagement (sec)



# EM Series Electrically Released NEMA C-face Brakes

## Ordering Information

### C-face Electrically Released Brakes Dynamic Torque Curves

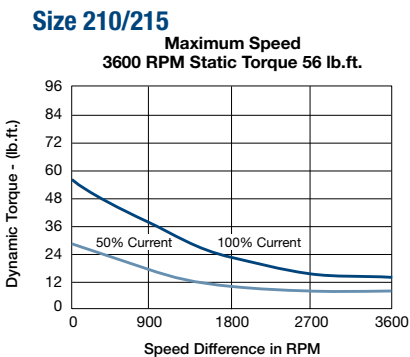
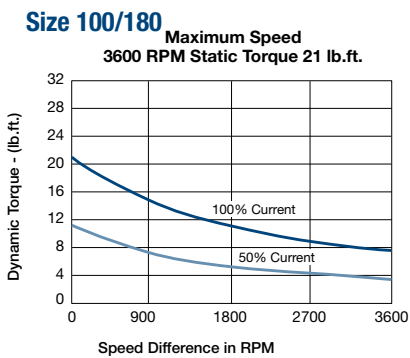
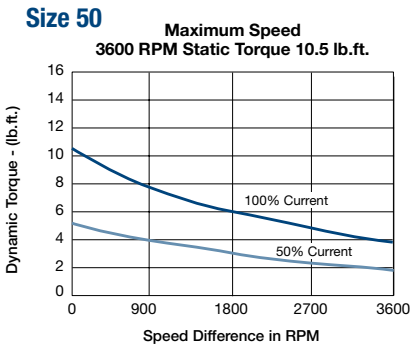

### 3. Select Accessories

Warner Electric Electro Modules can be fitted with several accessories to extend their capacity and ease of mounting.

### 4. Select Control

All electrically released modules require a control with a potentiometer that will vary brake channel output. For FBB and MBFB brake modules, the CBC-160, CBC-300, or CBC-500/550 is recommended. The FBC units require either a CBC-300 or a CBC 500/550 control.

### How to Order

1. Specify model number and voltage or the corresponding part number.
2. Specify conduit box, if desired.
3. Specify required control. See the Controls Section (page CLT-1).

### Ordering Example

EM-50-20FBB, 90V or 5370-169-234;  
5370-101-042 conduit box;  
CBC-160-2 control.

### Part Numbers

Model No.	Voltage DC	Part Number
<b>FBB Brake Module for use as brake only</b>		
EM-50-20FBB	24	5370-169-278
EM-50-20FBB	90	5370-169-279
EM-100-20FBB	24	5370-169-283
EM-100-20FBB	90	5370-169-284
EM-180-20FBB	24	5370-169-288
EM-180-20FBB	90	5370-169-289
EM-210-20FBB	24	5371-169-032
EM-210-20FBB	90	5371-169-029
EM-215-20FBB	24	5371-169-100
EM-215-20FBB	90	5371-169-054
<b>FBC Brake Module for use with EM clutch</b>		
EM-50-20FBC	24	5370-169-233
EM-50-20FBC	90	5370-169-234
EM-100-20FBC	24	5370-169-238
EM-100-20FBC	90	5370-169-239
EM-180-20FBC	24	5370-169-243
EM-180-20FBC	90	5370-169-244
EM-210-20FBC	24	5371-169-031
EM-210-20FBC	90	5371-169-028
<b>MBFB Motor Brake Module</b>		
EM-50-20MBFB	24	5370-169-248
EM-50-20MBFB	90	5370-169-249
EM-100-20MBFB	24	5370-169-253
EM-100-20MBFB	90	5370-169-254
EM-180-20MBFB	24	5370-169-258
EM-180-20MBFB	90	5370-169-259
EM-210-7/8-20MBFB	24	5371-169-101
EM-210-7/8-20MBFB	90	5371-169-072
EM-210-20MBFB	24	5371-169-033
EM-210-20MBFB	90	5371-169-030

### Subheads

Description	EM Size	Part No.
Conduit Box	EM series	5370-101-042
	All sizes	
Base Mount Kit for 2030 FBC	50/100	5370-101-004
	180	5370-101-002
	210/215	5371-101-019
Motor Mount Kit for 20 FBB, 1020 FBC	50/100	5370-101-078
	180	5370-101-079
	210/215	5371-101-012
Cover Kit	50/100/180	5370-101-076
	50/180 (FBB or MBFB)	5370-101-082



# EM-FBB Series Electrically Released NEMA C-face Brakes

## EM-20 FBB Brake Module

### SIZE 50/100/180

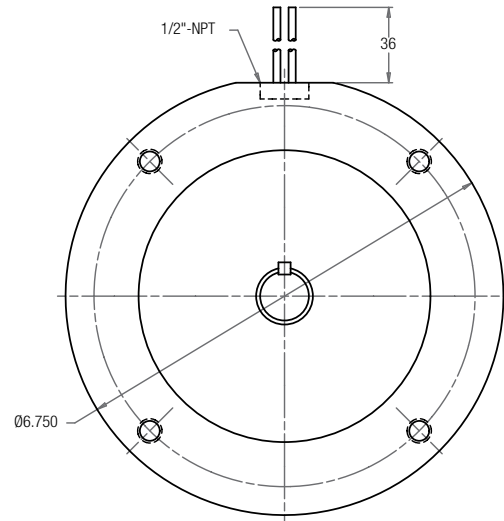
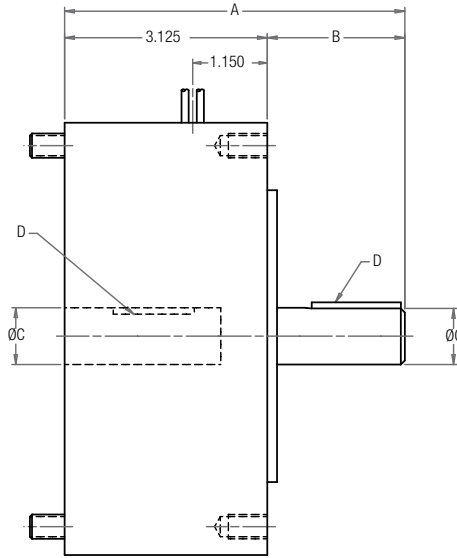

### SIZE 210/215

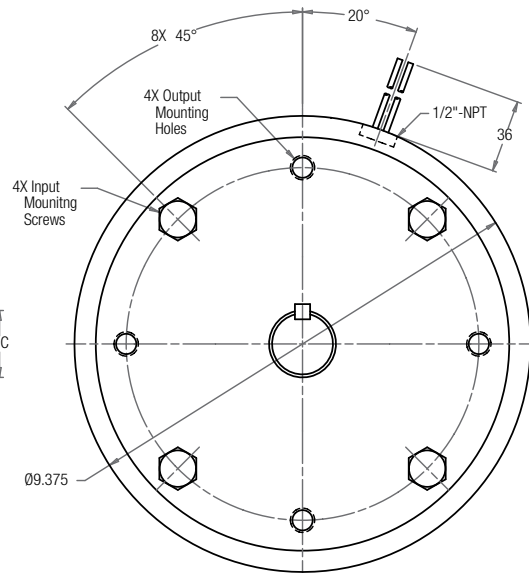
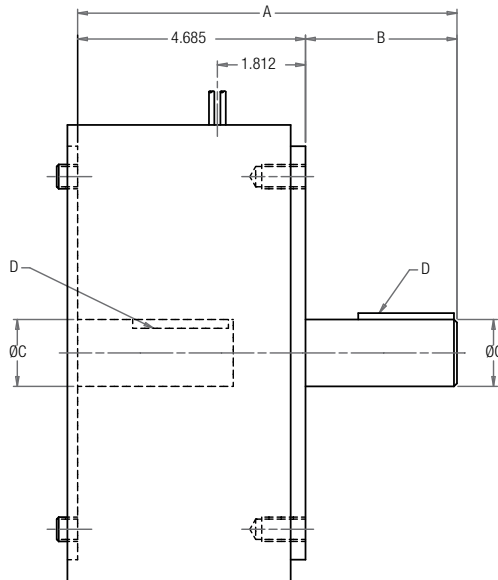

### Dimensions

Size	A	B	C	D
50	5.165	2.040	0.625	3/16 x 3/16
100	5.186	2.061	0.625	3/16 x 3/16
180	5.246	2.121	0.875	3/16 x 3/16
210	7.299	2.614	1.125	1/4 x 1/4
215	7.799	3.114	1.375	5/16 x 5/16

For standard NEMA frame dimensions, see page G-3.

# EM-FBC Series Electrically Released NEMA C-face Brakes

## EM-20FBC Brake Module for use with a Clutch

### SIZE 50/100/180

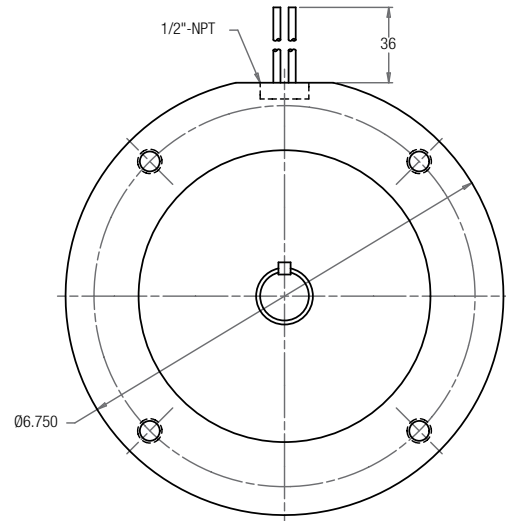
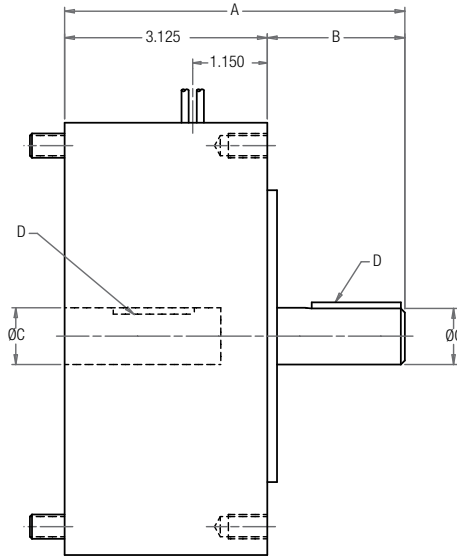

### SIZE 210/215

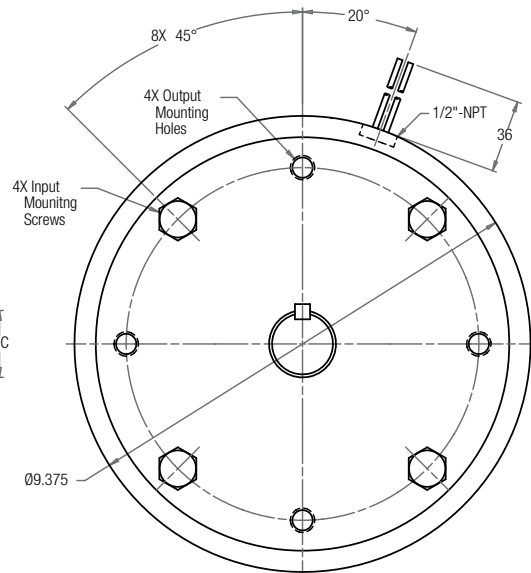
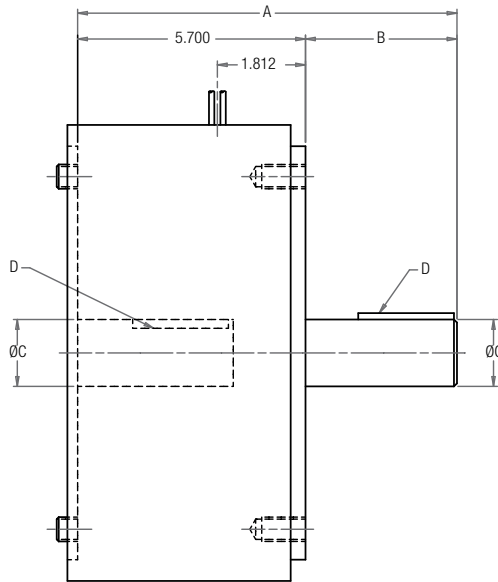

### Dimensions

Size	A	B	C	D
50	5.165	2.040	0.625	3/16 x 3/16
100	5.186	2.061	0.625	3/16 x 3/16
180	5.246	2.121	0.875	3/16 x 3/16
210	8.314	2.614	1.125	1/4 x 1/4

For standard NEMA frame dimensions, see page G-3.

# EM-MBFB Series Electrically Released NEMA C-face Brakes

## EM-20 MBFB Motor Brake Module

### SIZE 50/180

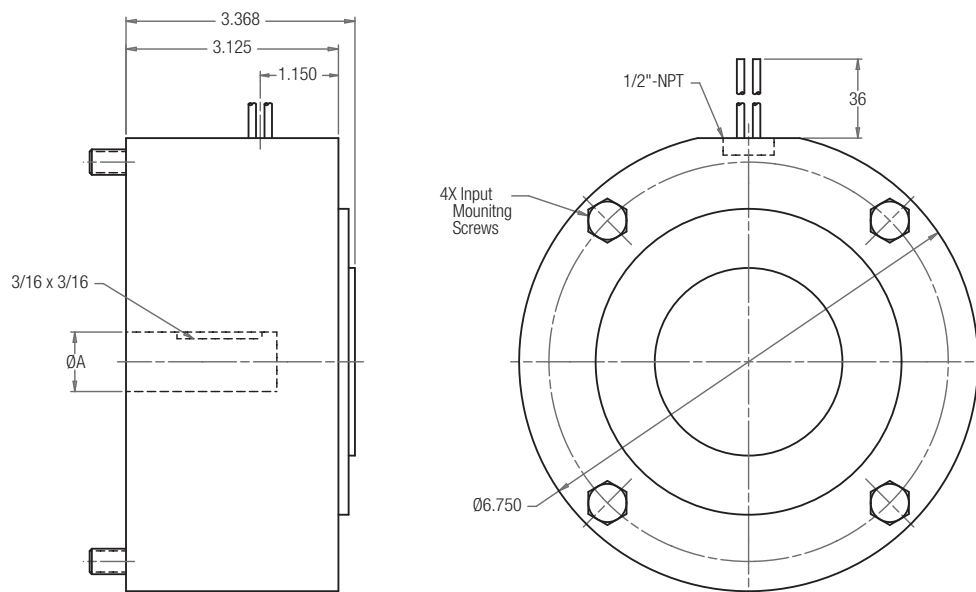

### SIZE 210

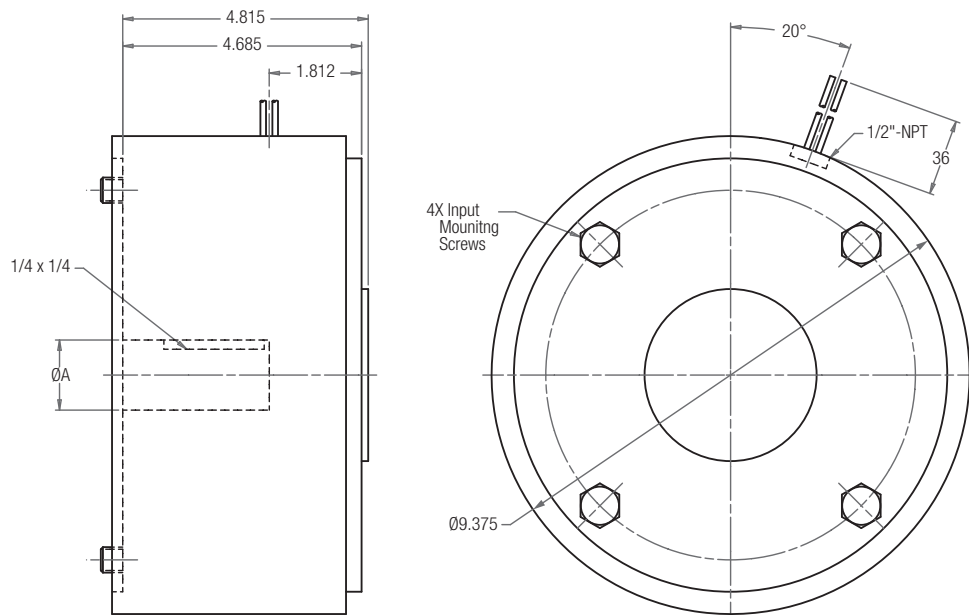

### Dimensions

Size	A
50	0.625
180	0.875
210	1.125

For standard NEMA frame dimensions, see page G-3.

# EM Series Electrically Released NEMA C-face Brakes

## Enclosing EM Series

Clean, quiet, operation. Nothing can get in, nothing can get out. Enclosed design eliminates damage to the working components. Prevents friction wear particles from escaping.

### Totally Enclosed Version

The Enclosed Electro Module packages the hardworking components from EM products into a totally enclosed housing. This rugged housing keeps wear particles in and contaminants out and provides quiet operation. Pre-burnished at the factory for rated torque directly out-of-box. When enclosed, they are suitable for most industrial applications and tolerate infrequent, light washing.

- Keeps contaminants out
- Keeps wear particles in
- Quiet operation
- Finned for heat dissipation
- UL listed when optional conduit box is installed

### Heat Dissipation Curves

#### EM-50 with Cover Kit

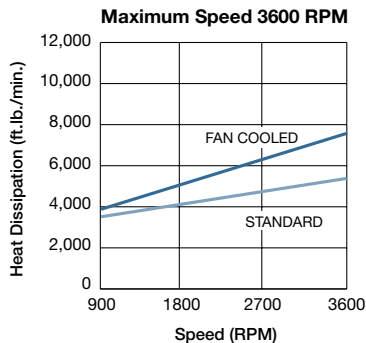

#### EM-100/180 with Cover Kit

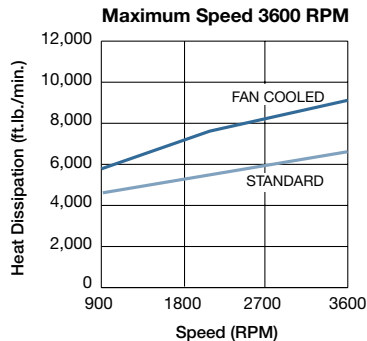

## To convert any EM Series Electro Module 50, 100, and 180 sizes to an enclosed model, purchase optional Cover Kit

### Enclosed Electro Module 10-20FBC, 20-30FBC

Part Number 5370-101-076

An optional cover kit can be purchased separately to enclose the open vents in the housing. Each cover kit includes two vent covers, two gaskets and four screws needed to convert a vented Electro Module to an enclosed design (non-washdown).

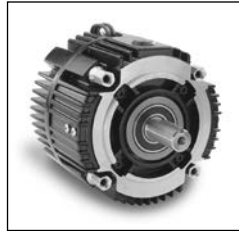

### Enclosed Electro Module-Brake Only 20FBB or 20MBFB

Part Number 5370-101-082 For Brake Only

An optional cover kit can be purchased separately to enclose the open vents in the housing and a cover plate to close off the back of the module. Each cover kit includes two vent covers, two gaskets, four screws and one cover plate needed to convert a vented Electro Module 20 to an enclosed design (non-washdown).



#### NOTE:

Enclosed option is not available for existing 210 & 215 size Electro Modules (EM). See page A-26 for enclosed versions of size 210 & 215 in MBFB and FBB Series.

### Packaged Performance Products Service Parts for Electrically Released Brakes

#### \* Permanent Magnet Brakes

FB Series Shaft Mounted Brakes . . . . .	SP-2
ER Series Flange Mounted Brakes . . . . .	SP-4

#### \* EM

UM-FBC Series Clutch/Electrically Released Brakes . . . . .	N/A
EM-FBB, EM-FBC, EM-MBFB Series Brake Modules . . . . .	N/A

\* It is recommended that electrically released brakes such as the EM-FBB, UM-FBC and EM or EM-MBFB not be rebuilt in the field. Specific custom-fixtures are used during factory assembly that ensure proper alignment of internal components and therefore unit function. These brakes are commonly used in applications involving personnel or equipment safety and an incorrectly rebuilt brake might result in danger to personnel or damage to expensive equipment. Therefore, replacement components are not available for these products.



When replacing components in clutches and brakes several guidelines are appropriate. In all cases, when replacing worn friction surfaces both the components need to be replaced. In many cases, the splined hubs should be inspected and replaced if worn.

### Common Replacement Practices:

#### Electrically released brakes

- On all Electrically released brakes the magnet and armature are only sold as a matched set and must be replaced as a set.

#### A note on burnishing:

When new friction surfaces are installed it will be necessary to burnish the unit prior to returning to full production rates. Burnishing is the act of wearing in the friction faces to ensure full engagement and therefore full torque. Burnishing is achieved by simply cycling the unit under less than full load (machine empty, if possible). Most units will achieve full torque in less than 100 cycles. Refer to the service manual for more details.

# FB Series Electrically Released Brakes

FB-375, FB-475, FB-650

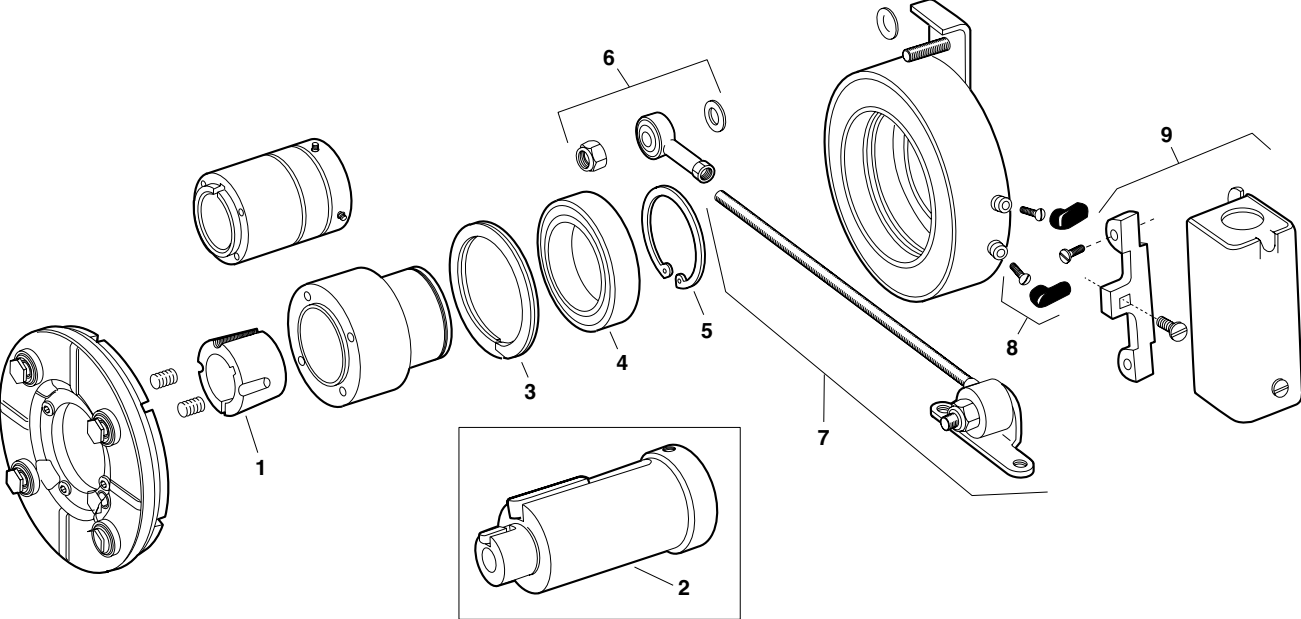

### Service Parts



# FB Series Electrically Released Brakes

## FB-375, FB-475, FB-650

### Component Parts

Item	Description	FB-375		FB-475		FB-650	
		Part No.	Qty.	Part No.	Qty.	Part No.	Qty.
<b>Optional Parts</b>							
1	*Bushing	N/A		180-0410 1/2" bore to 180-0418 1" bore	1	180-0421 1/2" bore to 180-0435 1-3/8" bore	1
	Adapter (optional)		1		1		1
	5/8" motor shaft	5380-101-005					
2	7/8" motor shaft	5380-101-004					
	1-1/8" motor shaft			5381-101-003			
	1-3/8" motor shaft					5382-101-003	
	1-5/8" motor shaft					5382-101-002	
<b>Service Parts</b>							
3	Retainer ring	748-0101	1	748-0102	1	748-0104	1
4	Ball bearing	166-0150	1	166-0110	1	166-0104	1
5	Retainer ring	748-0018	1	748-0002	1	748-0004	1
6	Torque arm mount assembly	5380-101-007	1	5381-101-006	1	5382-101-007	1
7	Torque arm rod assembly	5380-112-001	1	5381-112-001	1	5382-112-001	1
8	Terminal accessory	5311-101-001	1	5311-101-001	1	5311-101-001	1
9	Conduit Box	5200-101-010	1	5200-101-010	1	5200-101-010	1

\*See page B-3 for specific part numbers.

These units, when used with the correct Warner Electric conduit box, meet the standards of UL508 and are listed under guide card #NMTR2, file #59164. Magnet and armature are not field replaceable.



### Service Parts

# ER Series Electrically Released Brakes

## ER-375, ER-475, ER-650

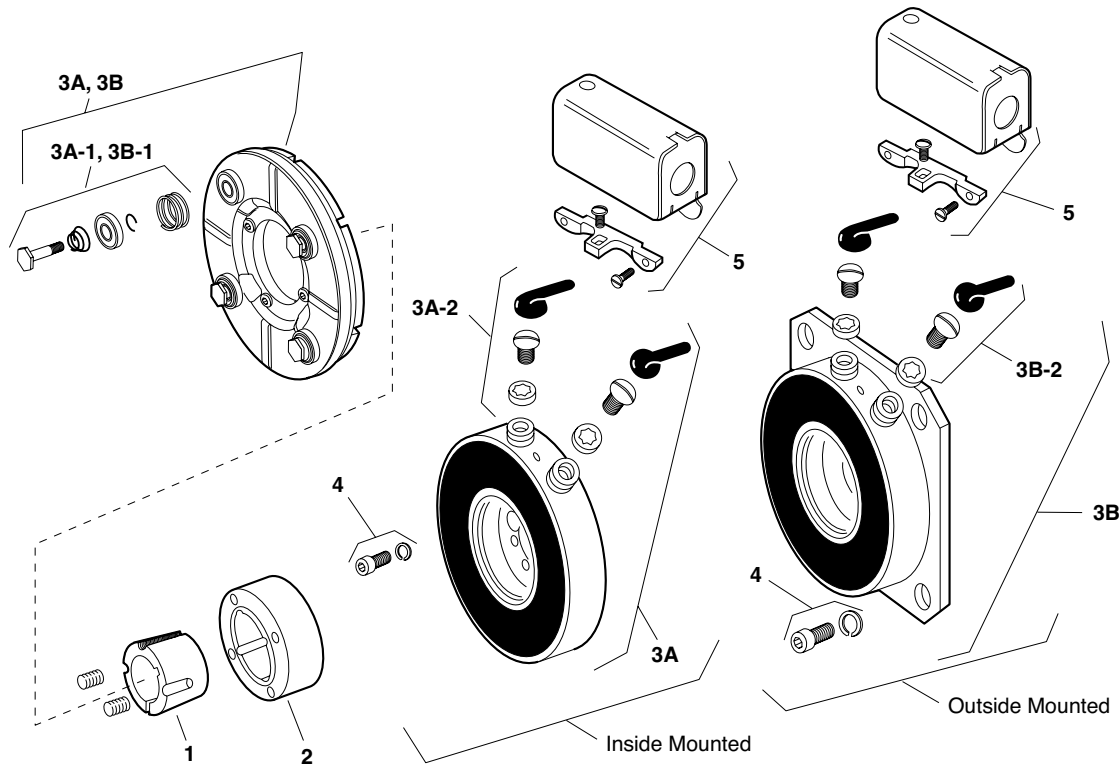

### Component Parts

Item	Description	ER-375		ER-475		ER-650	
		Part No.	Qty.	Part No.	Qty.	Part No.	Qty.
1	†Bushing			180-0410-0418 (1/2" to 1" Bore)	1	180-0421-0435 (1/2" to 1-3/8" Bore)	1
2	Hub			540-0849	1	540-0848	1
	1/2" Bore	540-0846	1				
	5/8" Bore	540-0847	1				
3A	Magnet and Armature (Inside Mounted, 90 Volt) Sold only in matched pairs*			5255-5	1	5256-6	1
3A-1	Autogap Accessory			5391-101-003	4	5392-101-003	4
3A-2	Terminal Accessory			5103-101-002	1	5103-101-002	1
3B	Magnet and Armature (Outside Mounted, 90 Volt) Sold only in matched pairs*	5254-1	1	5255-6	1	5256-7	1
3B-1	Autogap Accessory	5390-101-002	3	5391-101-003	4	5392-101-003	1
3B-2	Terminal Accessory	5103-101-002	1	5103-101-002	1	5103-101-002	1
4	Mounting Accessory						
	Inside Mount			5255-101-001	1	5256-101-003	1
	Outside Mount	5254-101-002	1	5255-101-002	1	5256-101-003	1
5	Conduit Box	5200-101-010	1	5200-101-010	1	5200-101-010	1

† See page B-3 for specific part numbers.

\* Magnets and armatures sold only in pre-burnished sets to assure rated torque available upon installation.

These units, when used with the correct Warner Electric conduit box, meet the standards of UL508 and are listed under guide card #NMTR2, file #59164.



### Service Parts

# ER Series Electrically Released Brakes

**ER-825, ER-1225**

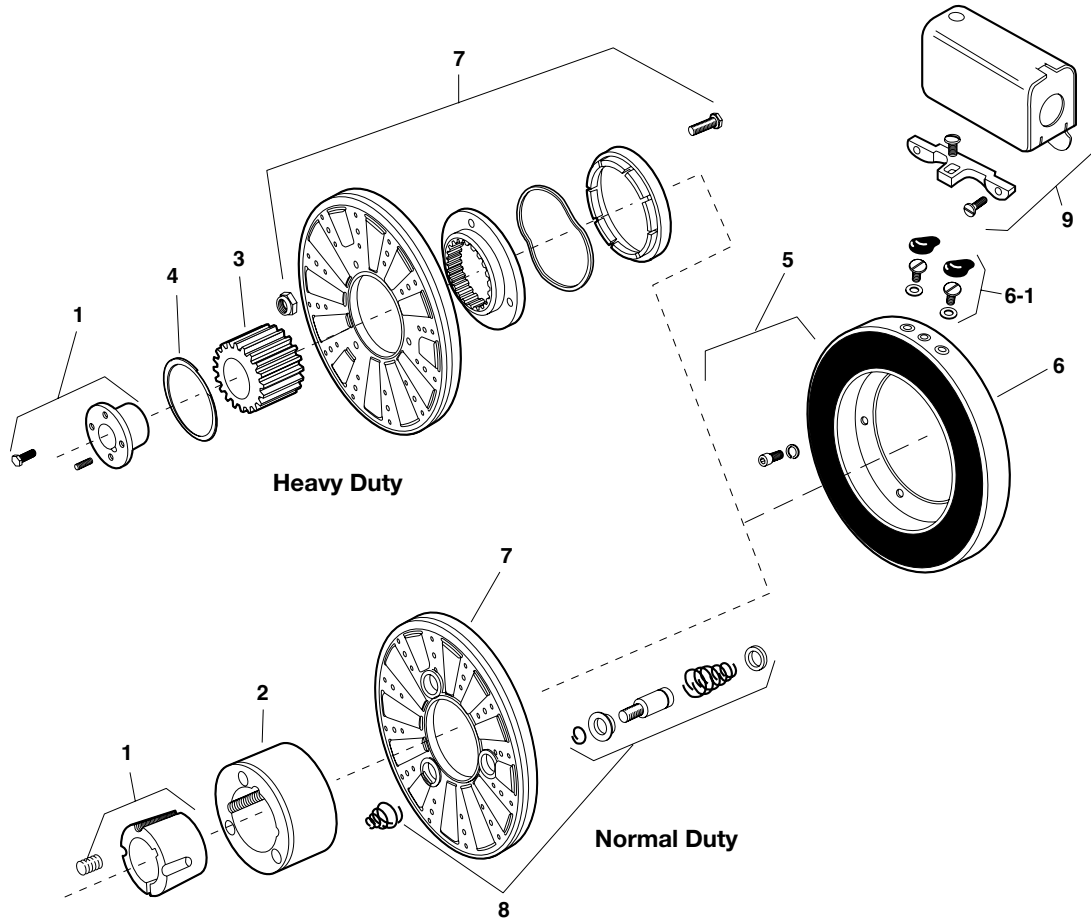

## Component Parts

Item Description	ER-825 Normal Duty		ER-825 Heavy Duty		ER-1225 Normal Duty		ER-1225 Heavy Duty	
	Part No.	Qty.	Part No.	Qty.	Part No.	Qty.	Part No.	Qty.
1 †Bushing	180-0137-180-0149	1	180-0008-180-0018	1	180-0262-180-0295	1	180-0026-180-0057	1
	7/8" to 1-5/8" Bore		7/8" to 1-1/2" Bore		15/16" to 3" Bore		3/4" to 2-11/16" Bore	
2 Armature Hub	540-0394	1			540-0015	1		
3 Splined Hub			540-0057	1			540-0064	1
4 Retainer Ring			748-0006	1			748-0005	1
5 Mounting Accessory, I.M.	5321-101-001	1	5321-101-001	1	5321-101-001	1	5321-101-001	1
6 & 7 Magnet (I.M.) and Armature sold only in matched pairs*	24V 5250-31	1	5250-26	1				
	90V 5250-30	1	5250-25	1	5252-9	1	5252-4	1
6-1 Terminal Accessory	5311-101-001	1	5311-101-001	1	5311-101-001	1	5311-101-001	1
8 Autogap Accessory	5201-101-008	3			5201-101-008	4		
9 Conduit Box	5200-101-010	1	5200-101-010	1	5200-101-010	1	5200-101-010	1

† See pages B-2 to B-3 for specific part numbers.

\* Magnets and armatures sold only in pre-burnished sets to assure rated torque available upon installation.

These units, when used with the correct Warner Electric conduit box, meet the standards of UL508 and are listed under guide card #NMTR2, file #59164.



## Service Parts



---

# General Engineering Data



**G**

# Mechanical Data Application Engineering

---

- Ordering Information / Standard NEMA Frame Dimensions.....** G-3
- Mechanical Data / Dynamic Torque .....** G-4
- Mechanical Data / Rotational Speed.....** G-6
- Mechanical Data / Clutch Field Restraining Devices.....** G-7
- Electrical Data / Coil Ratings .....** G-8
- Electrical Data / Installation Procedure .....** G-11
- Electrical Data / Coil Suppression & Clutch/Brake Overlap .....** G-12
- Electrical Data / Overexcitation .....** G-13



# Standard NEMA Frame Dimensions Ordering Information

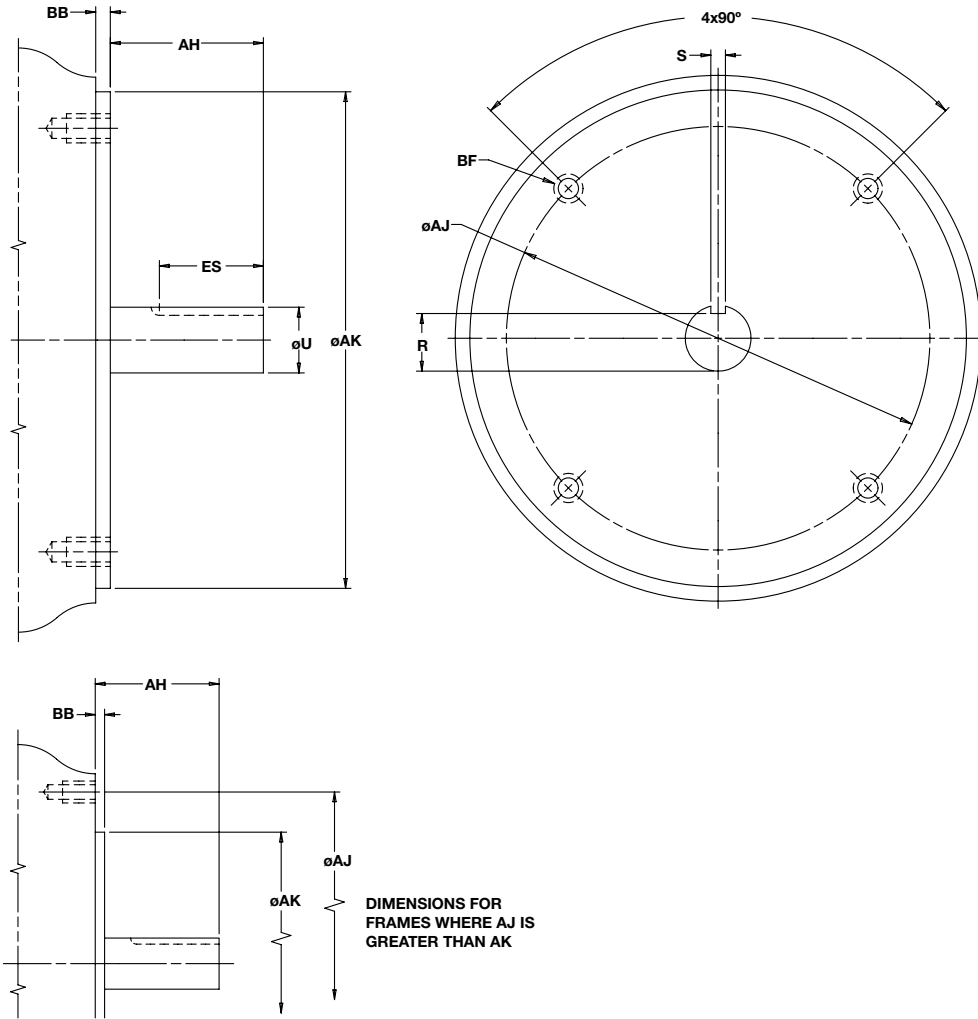

## Specifications

Module Size	NEMA Frame Size	AH	AJ	AK	BB	BF	ES	R	S	U
50	56C/48Y	2.06	5.875	4.500	.16 MAX	3/8-16 UNC	1.41 MIN	0.517	0.188	0.625
100	56C/48Y	2.06	5.875	4.500	.16 MAX	3/8-16 UNC	1.41 MIN	0.517	0.188	0.625
180	143TC/145TC	2.12	5.875	4.500	.16 MAX	3/8-16 UNC	1.41 MIN	0.771	0.188	0.875
210	182TC/184TC	2.62	7.250	8.500	.25 MIN	1/2-13 UNC	1.78 MIN	0.986	0.250	1.125
215	213TC/215TC	3.12	7.250	8.500	.25 MIN	1/2-13 UNC	2.41 MIN	1.201	0.312	1.375

Note: Warner Electric Modules are designed to comply with standard NEMA frame dimensions for mounting. Reference to each particular frame size is given in the individual selection tables for each type of Warner Electric module.

# Mechanical Data Dynamic Torque

## NOTES:

Speed difference means the difference in speed between one friction face and the other at the moment of engagement. The intersection of the top curve and the speed difference is the maximum torque produced by the unit. When both friction faces are engaged and rotating at the same speed, the unit is said to be locked-in and produces the maximum static torque (zero speed difference).

The % lines indicate the percentage of full voltage being used. Example: If 90 volt unit runs at 45 volts, use the 50% line.

Average Torque = Dynamic Torque at  $1/2$  operating speed. Example: If operating speed is 1800, use dynamic torque at 900.

**Size 120** Maximum Speed 10,000 rpm  
Static Torque 5 lb./in.

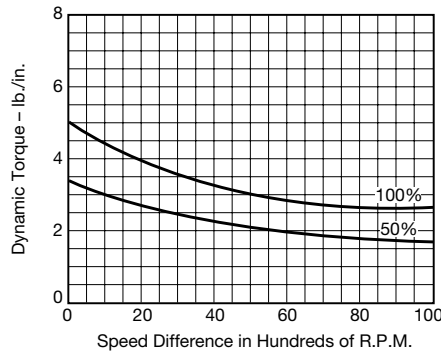

**Size 170** Maximum Speed 10,000 rpm  
Static Torque 15 lb./in.

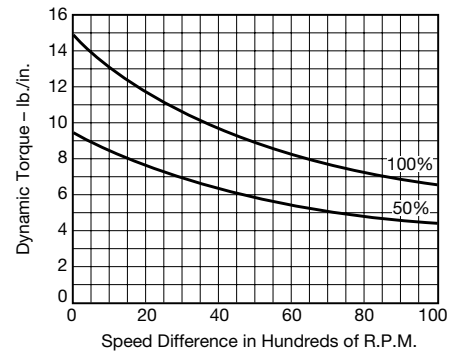

**Size 250** Maximum Speed 7,500 rpm  
Static Torque 70 lb./in.

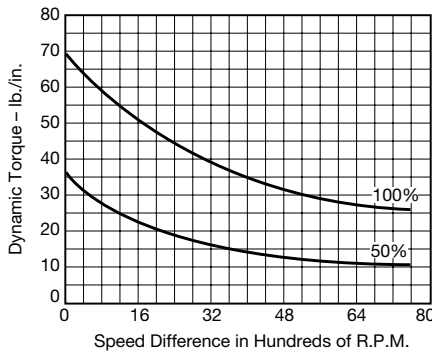

**Size 400** Maximum Speed 4,500 rpm  
Static Torque 270 lb./in.

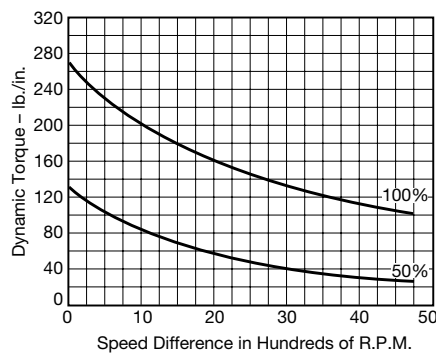

**Size 500-SF** Maximum Speed 4,000 rpm  
Static Torque 50 lb./ft.

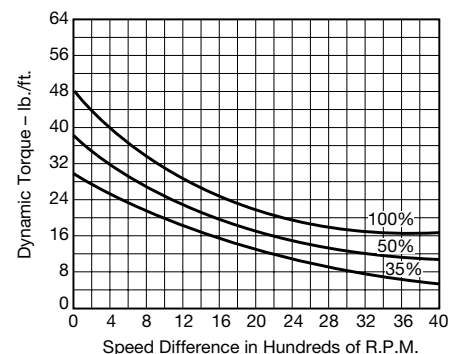

**Size 500-SF** Maximum Speed 4,000 rpm  
Static Torque 50 lb./ft.

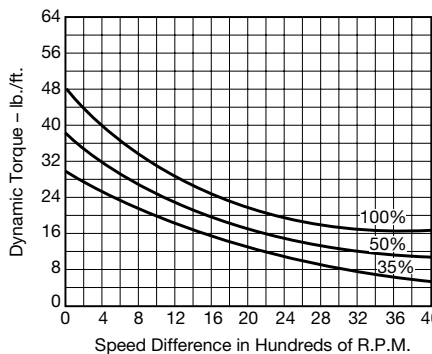

**Size 650** Maximum Speed 3,600 rpm  
Static Torque 95 lb./ft.

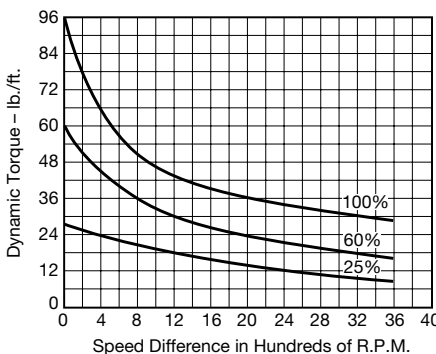

**Size 825-SF** Maximum Speed 3,600 rpm  
Brg. Mtd. Static Torque 150 lb./ft.

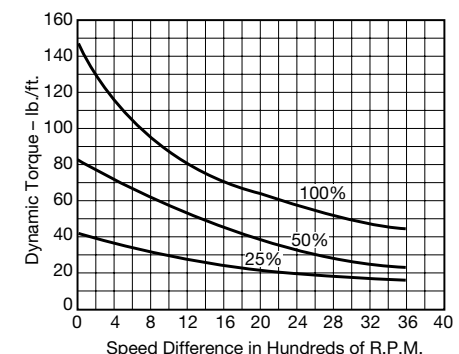

NOTE: Torque values are in inch lbs. for size 400 and smaller, and in ft.lbs. for size 500 and larger.

# Mechanical Data Dynamic Torque

**Size 825** Maximum Speed 4,000 rpm  
Electro-Pack 3,600 rpm  
Static Torque 125 lb./ft.

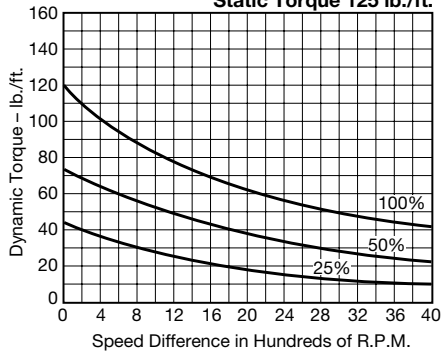

**Size 825-MB** Maximum Speed 4,000 rpm  
Static Torque 80 lb./ft.

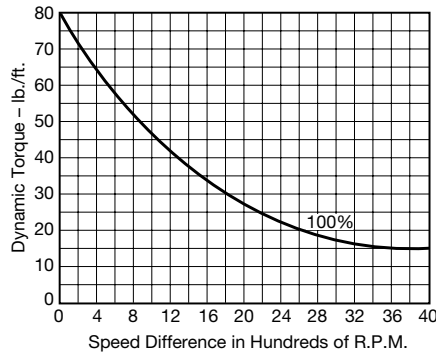

**Size 1000** Maximum Speed 3,600 rpm  
Electro-Pack 3,000 rpm  
Static Torque 240 lb./ft.

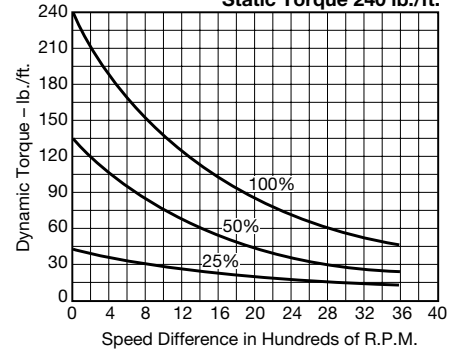

**Size 1000-MB** Maximum Speed 3,600 rpm  
Static Torque 160 lb./ft.

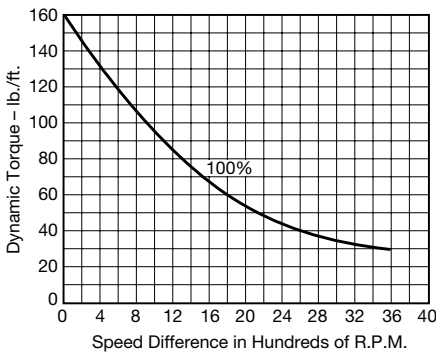

**Size 1225** Maximum Speed 3,000 rpm  
Static Torque 465 lb./ft.

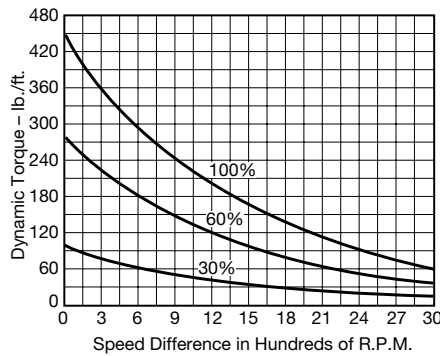

**Size 1225-MB** Maximum Speed 3,000 rpm  
Static Torque 260 lb./ft.

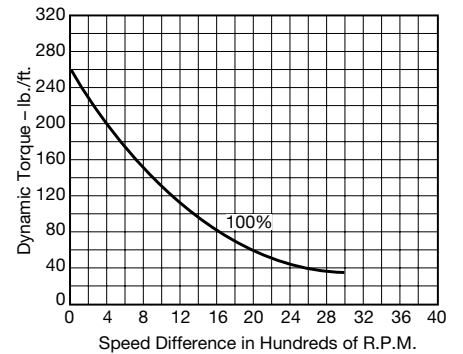

**Size 1525** Maximum Speed 2,000 rpm  
Electro-Pack 1,800 rpm  
Static Torque 700 lb./ft.

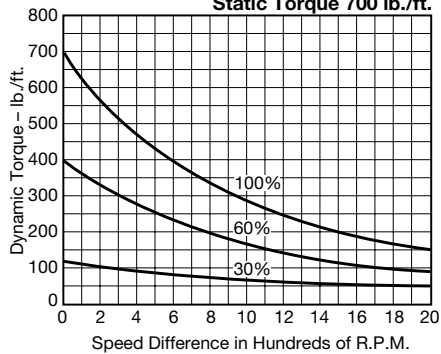

**Size 1525-Hi Torque** Maximum Speed 2,000 rpm  
Static Torque 1,350 lb./ft.

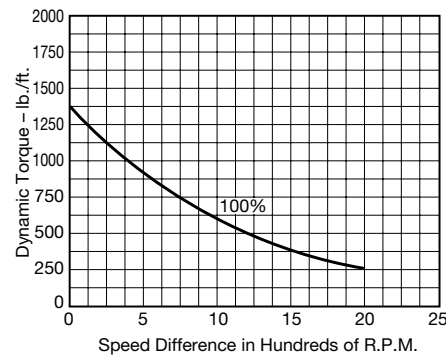

## Rotational Speed

Rotational speed of a clutch or brake is an important consideration when selecting a unit for a particular application. Numerous factors must be considered, such as the maximum rated speed of the clutch/brake unit, the dynamic torque required, the heat dissipation needed, the effect of speed on wear rate, and torque stability at very low speeds. Each of these issues are separate, and sometimes interrelated, but always important in selecting the right product for an application.

## Maximum RPM Rating

The most important rotational speed consideration is the maximum rated RPM capability of a unit. DO NOT exceed this rating. Exceeding the maximum RPM of a unit may cause personal injury and/or machine damage. Maximum rated speeds are based on the structural integrity of the rotating components and associated shaft and bearing capabilities. If the RPM rating is exceeded, structural failure may occur, or the unit may experience premature bearing failure and/or premature friction material wear out.

## Dynamic Torque

When determining the correct size clutch/brake for an application, dynamic torque at the highest slip speed is often the determining factor. As you can see by reviewing the dynamic torque curves for different units as shown starting on page G-4, dynamic clutch/brake torque usually decreases with higher speeds. As slip RPM increases, the coefficient of friction of a unit decreases, causing a decrease in dynamic torque availability. Be careful to consider this when selecting the appropriate unit size needed.

## Heat Dissipation

Heat dissipation is inversely related to dynamic torque. As RPM increases, the heat dissipation ability of a unit increases. When an armature is rotating, the heat dissipation rate is proportional to the aerodynamic fan effect of the rotating armature. The faster the armature rotates, the greater the heat dissipation. This is illustrated with a typical catalog curve as shown in Figure 1. It's interesting to note that, at zero RPM, the unit still has some heat dissipation capability. This is due to convection and radiation, but is usually not an important consideration.

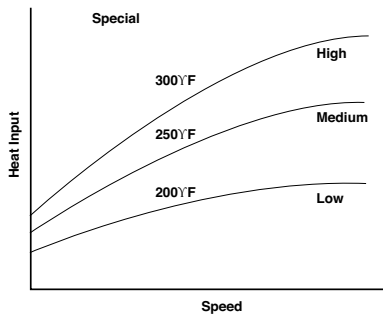

Figure 1: Typical Heat Dissipation Characteristics

## Wear Rate

The wear rate of friction surfaces is dependent on the clamping pressure of the mating surfaces as well as the surface velocity between the wearing surfaces. Many variables are involved in predicting wear life, of which RPM is probably the most influential. Typically, the wear rate will increase directly with the rubbing velocity distance. Another way of stating this is the higher the relative engagement speeds of two rotating parts, the longer they are allowed to slip against each other and the faster the wear rate.

## Low Speed Operation

The effect of low speed usage should also be considered in applications. Performance of clutch/brake units at less than 100 RPM may be very different than at higher RPM. This is due to “burnish” characteristics of friction surfaces.

## Wear In

“Burnish” is the wear in, or mating of two surfaces. When new, these surfaces have manufacturing features which include roughness and waviness. When these surfaces come into initial contact, only the high spots actually meet. See Figure 2. This results in only a small surface area in contact, while the non-contact surface area is “air.” The result is low torque. As the mating surfaces continue to engage and slip against each other, the high spots are worn down and more surface area is in contact, thus increasing torque capability. This wear in period, or burnish, typically occurs in the first few hundred cycles of a clutch/brake’s life. Faster slip speeds and higher loads mean fewer cycles needed to complete the burnish process. For applications where the speed is less than 100 RPM, the required application torque

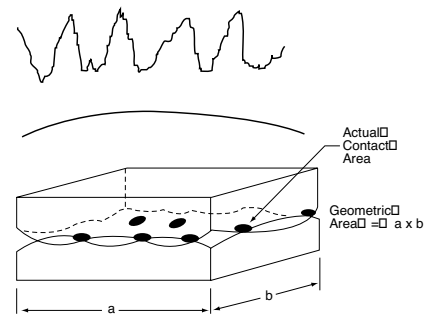

Figure 2: Unburnished Contact Areas

should be doubled to compensate for the low speed “burnish” that the unit experiences. A low speed burnish will require many cycles before full torque and stability are achieved. For example, if an application is determined to need 20 ft.lbs. of static torque, an SF-400 clutch could be selected. But, if the application is only 100 RPM or less, then an SF-500 unit should be the choice to compensate for the low RPM usage, as indicated on the selection chart found on page G-4.

Careful consideration of rotating speeds will help the selection process of an application. Follow these guidelines and the proper clutch/brake selected will provide troublefree operation.

# Mechanical Data Clutch Field Restraining Devices

Many Warner Electric clutch assemblies have a bearing mounted stationary field. By design the bearing maintains its proper position between the field and rotor making it easy for the customer to mount the field-rotor assembly. However, the bearing has a slight drag which tends to make the field rotate if not restrained. And, since the field has lead wires attached, it must be restrained to prevent rotation and pulling of these wires. To counteract this rotational force, the field has a "torque tab" to which the customer must attach an appropriate anti-rotational restraint.

A few hints regarding proper torque tab restraints are in order. First and foremost, it is important to recognize that the force to be overcome is very small and the tab should not be restrained in any manner which will preload the bearing. For example, if the clutch is mounted with the back of the field adjacent to a rigid machine member the customer should not attach a capscrew tightly between the tab and the machine member. This may pull the tab back against the rigid member as shown in Figure 1 and preload the bearing. The recommended methods are illustrated in Figures 2, 3, and 4. The method selected is primarily a matter of customer preference or convenience.

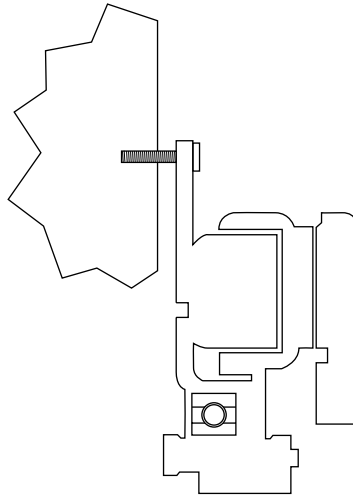

**Figure 1:**  
Rigid member

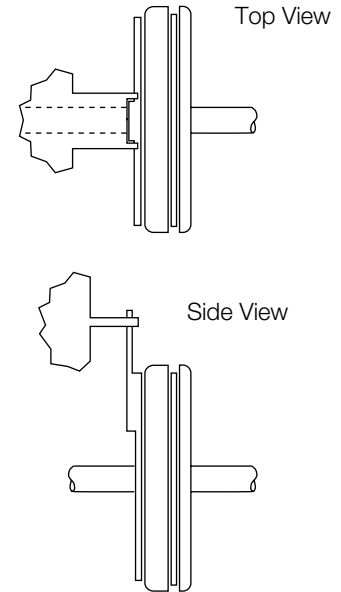

**Figure 2:**  
Rigid Member with Slot  
Straddling Tab  
(Preferred)

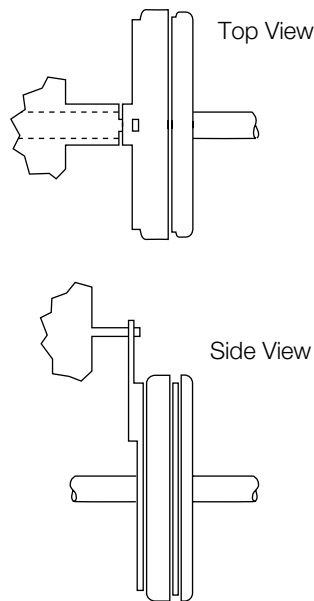

**Figure 3:**  
Pin in Hole  
Loosely  
(Preferred)

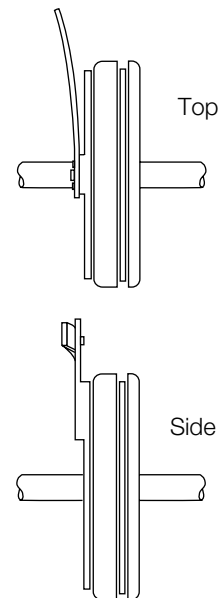

**Figure 4:**  
Flexible Strap  
(Preferred)

# Electrical Data Coil Ratings

EC/EB-375	EC			EB		
	90	24	6	90	24	6
Voltage – DC	90	24	6	90	24	6
Resistance @ 20° C – Ohms	453.5	29.3	2.10	446.8	29.3	1.96
Current – Amperes	.198	.82	2.85	.201	.82	3.07
Watts	17	20	17	18	20	18
Coil Build-up – milliseconds	62	60	59	50	60	52
Coil Decay – milliseconds	13	14	15	8	14	10

EC/EB-475	EC			EB		
	90	24	6	90	24	6
Voltage – DC	90	24	6	90	24	6
Resistance @ 20° C – Ohms	368.9	37.8	2.32	443.1	28.8	2.05
Current – Amperes	.244	.64	2.58	.203	.88	2.93
Watts	22	15	16	18	21	18
Coil Build-up – milliseconds	92	91	90	80	75	70
Coil Decay – milliseconds	18	17	16	8	9	9

EC/EB-650	EC			EB		
	90	24	6	90	24	6
Voltage – DC	90	24	6	90	24	6
Resistance @ 20° C – Ohms	225	17.7	1.16	257.2	18.3	1.24
Current – Amperes	.4	1.36	5.19	.35	1.3	4.84
Watts	36	33	31	32	31	29
Coil Build-up – milliseconds	120	115	110	112	108	105
Coil Decay – milliseconds	20	20	20	12	13	14

FB/ER-375, 475, 650	FB-375		FB-475		FB-650	
	90	24	90	24	90	24
Voltage – DC	90	24 <td>90</td> <td>24 <td>90</td> <td>24</td> </td>	90	24 <td>90</td> <td>24</td>	90	24
Resistance @ 20° C – Ohms	446	29	310	22	235	16
Current – Amperes	.201	.822	.300	1.09	.380	1.426
Watts	18	19	27	26	34	34
Coil Build-up – milliseconds	40	40	80	80	90	90
Coil Decay – milliseconds	5	10	8	10	10	10

ER-825, 1225	ER-825		ER-1225	
	90	24	35-75	
Voltage – DC	90	24	35-75	
Resistance @ 20° C – Ohms	305	21.5	235	
Current – Amperes	.29	1.1	.383	
Watts	26	27	35	
Coil Build-up – milliseconds	400	–	700	
Coil Decay – milliseconds	20	–	20	

EC/EB-825	EC			EB		
	90	24	6	90	24	6
Voltage – DC	90	24	6	90	24	6
Resistance @ 20° C – Ohms	221	20.9	1.098	223.3	20.4	1.27
Current – Amperes	.407	1.15	5.464	.4	1.18	4.74
Watts	37	28	33	36	28	28
Coil Build-up – milliseconds	225	200	180	170	170	170
Coil Decay – milliseconds	130	122	115	80	75	70

EC/EB-1000	EC			EB		
	90	24	6	90	24	6
Voltage – DC	90	24	6	90	24	6
Resistance @ 20° C – Ohms	248.7	19.7	1.23	248.7	19.7	1.23
Current – Amperes	.36	1.22	4.87	.36	1.22	4.87
Watts	33	29	29	33	29	29
Coil Build-up – milliseconds	250	235	220	235	220	205
Coil Decay – milliseconds	70	75	80	70	75	80

EC/EB-1225	EC			EB		
	90	24	6	90	24	6
Voltage – DC	90	24	6	90	24	6
Resistance @ 20° C – Ohms	207.3	15.1	1.04	261.7	22.3	1.33
Current – Amperes	.43	1.59	5.79	.34	1.08	4.5
Watts	39	38	35	31	26	27
Coil Build-up – milliseconds	500	490	480	460	445	435
Coil Decay – milliseconds	220	230	240	190	160	140

ATC, ATTC, ATB, ATTB-25	ATC			ATB		
	6	24	90	6	24	90
Voltage – DC	6	24	90	6	24	90
Resistance @ 20° C – Ohms	1.37	20.2	290	1.37	20.2	290
Current – Amperes	4.38	1.19	.31	4.38	1.19	.31
Watts	26.3	28.6	27.9	26.3	28.6	27.9
Coil Build-up – milliseconds	145	145	145	145	145	145
Coil Decay – milliseconds	8	8	8	9	9	9

ATC, ATTC, ATB, ATTB-55	ATC			ATB		
	6	24	90	6	24	90
Voltage – DC	6	24	90	6	24	90
Resistance @ 20° C – Ohms	1.21	19.6	230	1.21	19.6	230
Current – Amperes	4.96	1.22	.39	4.96	1.22	.39
Watts	29.8	29.3	35.2	29.8	29.3	35.2
Coil Build-up – milliseconds	200	200	200	210	210	210
Coil Decay – milliseconds	20	20	20	35	35	35

ATC, ATTC, ATB, ATTB-115	ATC			ATB		
	6	24	90	6	24	90
Voltage – DC	6	24	90	6	24	90
Resistance @ 20° C – Ohms	1.02	16.5	182	1.02	16.5	182
Current – Amperes	5.91	1.46	.50	5.91	1.46	.50
Watts	35.4	35	44.6	35.4	35	44.6
Coil Build-up – milliseconds	145	145	145	150	150	150
Coil Decay – milliseconds	40	40	40	45	45	45



# Electrical Data Coil Ratings

UM/EM/UMFB/EMFB	Clutch	UM/EM Brake	Clutch	UM/EM Brake	Clutch	UM/EM Brake	UMFB/EMFB Brake	UMFB/EMFB Brake	
Voltage – DC	90	90	24	24	6	6	24	90	
Resistance (ohms)	EM-50	452	429	31.8	28.8	1.9	1.9	28.8	429
	EM-100	392	392	26.7	26.7	1.8	1.8	21.7	308
	EM-180	392	392	26.7	26.7	1.8	1.8	21.7	308
	EM-210/215	248	248	17.9	17.9	1.22	1.22	13.3	205
Amperes	EM-50	.20	.21	.76	.83	3.2	3.2	.83	.21
	EM-100	.23	.23	.90	.90	3.3	3.3	1.1	.29
	EM-180	.23	.23	.90	.90	3.3	3.3	1.1	.29
	EM-210/215	.36	.36	1.3	1.3	4.9	4.9	1.8	.38
Watts	EM-50	18	19	19	20	20	20	20	19
	EM-100	21	21	22	22	20	20	27	27
	EM-180	21	21	22	22	20	20	27	27
	EM-210/215	33	33	32	32	30	30	43	34
Build-up (millisecond)	EM-50	52	53	52	53	52	53	40	40
	EM-100	72	75	72	75	72	70	80	80
	EM-180	72	75	72	75	72	70	80	80
	EM-210/215	120	100	120	100	110	100	90	90
Decay (millisecond)	EM-50	6	5	6	5	6	5	5	5
	EM-100	12	10	12	10	12	10	8	8
	EM-180	12	10	12	10	12	10	8	8
	EM-210/215	20	10	20	10	20	10	10	10

# Electrical Data Coil Ratings

Unit Size	SF/PB 120			SF/PB 170			SF/PB 250		
Voltage – DC	6	24	90	6	24	90	6	24	90
Resistance @ 20°C – Ohms	6.32	104	1386	6.96	111.2	1506	5	76.4	1079
Current – Amperes	.949	.230	.065	.861	.215	.060	1.2	.314	.084
Watts	5.69	5.52	5.85	5.85	5.16	5.37	7.2	7.5	7.51
Coil Build-up – milliseconds	12	12	11	17	17	16	48	48	44
Coil Decay – milliseconds	8	8	7	8	7	6	15	15	13

Unit Size	SF/PB 400			SF-500			PB & PC 500			SF-650		
Voltage – DC	6	24	90	6	24	90	6	24	90	6	24	90
Resistance @ 20°C – Ohms	4.88	73	1087	1.076	14.9	206.1	1.36	23.8	251.1	1.16	17.7	225
Current – Amperes	1.23	.322	.083	5.58	1.61	.44	4.4	1.01	.36	5.19	1.36	.4
Watts	7.39	7.96	7.45	34	39	39	26	24	32	31	33	36
Coil Build-up – milliseconds	154	154	154	82	85	90	84	87	93	110	115	120
Coil Decay – milliseconds	62	60	55	40	40	40	38	35	30	50	50	50

Unit Size	PB-650			SF-825			SF-825 Brg			PB & PC 825			SF-1000			PB & PC 1000		
Voltage – DC	6	24	90	6	24	90	6	24	90	6	24	90	6	24	90	6	24	90
Resistance @ 20°C – Ohms	1.24	18.3	257.2	1.23	20.9	267.0	1.098	14.6	221	1.27	20.4	223.3	1.07	14.4	214.4	1.23	19.7	248.7
Current – Amperes	4.84	1.31	.35	4.9	1.15	.34	5.464	1.65	.407	4.74	1.18	.4	5.61	1.67	.42	4.87	1.22	.36
Watts	29	31	32	29	28	30	33	40	37	28	28	36	34	40	38	29	29	33
Coil Build-up – milliseconds	100	105	110	222	200	245	180	200	225	170	170	170	256	275	283	205	220	235
Coil Decay – milliseconds	50	50	50	105	120	100	115	120	130	70	75	80	123	105	90	70	75	80

Unit Size	SF-1225			PB & PC 1225			SF-1525			PB & PC 1525			SF-1525 H.T.	
Voltage – DC	6	24	90	6	24	90	6	24	90	6	24	90	6	90
Resistance @ 20°C – Ohms	1.21	19.5	268.3	1.33	22.3	261.7	1.11	15.5	239.1	1.45	19.8	258.4	55	113.4
Current – Amperes	4.97	1.23	.34	4.5	1.08	.34	5.41	1.55	.38	4.13	1.21	.35	10.83	.794
Watts	30	30	30	27	26	31	32	37	34	25	29	31	65	72
Coil Build-up – milliseconds	475	490	510	300	320	350	505	535	575	470	490	512	480	560
Coil Decay – milliseconds	240	230	220	190	190	190	230	237	215	200	170	140	210	160

NOTES: Build-up time equals current to approximately 90% of steady state value and flux to 90%. Decay time equals current to approximately 10% of steady state value and flux to 10%. Approximately because current leads or lags flux by a small amount.

# Electrical Data Installation Procedure

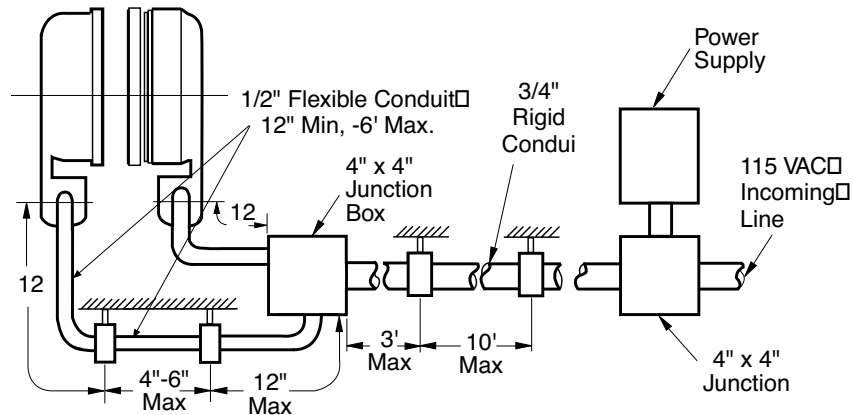

## Recommended Electrical Installation Procedure for Warner Electric Clutches and Brakes

Warner Electric clutches and brakes conform to UL (Underwriters Laboratories) requirements. All packaged products come with conduit boxes or are enclosed in housings with provision for electrical conduit connection. All sizes 400 and larger SF clutch fields and brake magnets accept UL conforming conduit boxes available from Warner Electric.

The National Electrical Code (NEC) requires that conductors subject to physical damage be adequately protected. When electrical conduit is used, a minimum of 12" of 1/2" flexible conduit is to be used between each brake and/or clutch and its box. This construction will prevent improper bearing loading in bearing mounted units and ease field and magnet assembly and disassembly.

Refer to the information below for proper installation practices and wire sizes.

Notwithstanding the above recommendations, all electrical installations should conform to NEC and/or other governing electrical codes.

## Recommended wire size versus maximum distance

Wire Size AWG	Fractional Horsepower Sizes 170-400			Integral Horsepower Sizes 500-1525		
	Distance (feet)			Distance (feet)		
	6 Volt	24 Volt	90 Volt	6 Volt	24 Volt	90 Volt
18	20	280	1000	4	65	700
16	30	430		6	95	
14	50	720		10	160	
12	75	720		10	160	
10	125			25	400	
8	200			40		

General construction wire type MTW or THW recommended.  
 #6 terminal screws (size 400 and smaller) are to be torqued to 15 in.lb.  
 #8 terminal screws (size 500 and larger) are to be torqued to 20 in.lb.

# Electrical Data Coil Suppression & Clutch/Brake Overlap

Users of electric clutch and brake systems are sometimes concerned that a clutch and brake will oppose each other or “overlap” during switching, i.e., when the clutch is switched off and the brake is switched on, or vice versa. This concern relates primarily to dual armature type clutch/brakes similar to the Warner Electric Electro Module product line, as compared to shuttle armature clutch/brakes.

In use, Warner Electric clutches and brakes are not subject to overlap when Zener diode coil suppression techniques are applied to the clutch/brake control. All Warner Electric clutch/brake controls use Zener diode suppression to eliminate any overlap situations.

The charts below graphically display current decay of the clutch and current rise of the brake with Zener diode and with straight diode suppression. In Chart 1, which shows brake and clutch operation with Zener diode suppression, the “Overlap Area” below the intersection of the brake and clutch current lines shows potential for the devices to fight one another. But this

intersection occurs at an extremely low current level and the armature Autogap® springs keep the friction surfaces of the brake armature and magnet separate at such low currents. Even though there is the appearance of a minor clutch/brake overlap in this instance, the brake armature has not yet contacted the brake magnet. Chart 2 shows a much larger overlap area since straight diode suppression is used in this circuit. Clutch current has not decayed fully as the brake is engaged and the load is brought to zero speed.

Clutch and brake coils are inductors. Inductance is the electrical equivalent to mechanical inertia and an energized coil dissipates its energy when turned “off.” Upon removal of power, voltage across an inductor reverses and current continues to flow in the same direction until the energy is fully dissipated. Without suppression in the control circuit, an arc can result from this potentially very large reverse voltage which can damage the electrical switching contacts.

Consequently, Zener diode suppression circuitry, by limiting the reverse voltage to

a sufficiently high but safe level, has two major benefits:

- Hastens coil decay
- Protects the switching contacts

The schematics below show circuits with no suppression and both straight diode and Zener diode suppression.

The rapid coil decay of Zener diode suppression lets users enjoy the major advantages which dual armatures have over single, “shuttle” armatures. These include:

- Better heat dissipation – greater area to give off heat and more “off” time.
- Longer life – two armatures absorb wear.
- Armature Autogap® self adjusting for the life of the unit
- Enhanced repeatability and controllability with the use of a light preload spring to keep the armatures in light contact with their mating surfaces, eliminating armature movement time and reducing noise and spline wear. Warner Electric utilizes this preload spring in some packaged clutch/brake models including ceramic EPs and Unimodules and Smooth Start Unimodules.

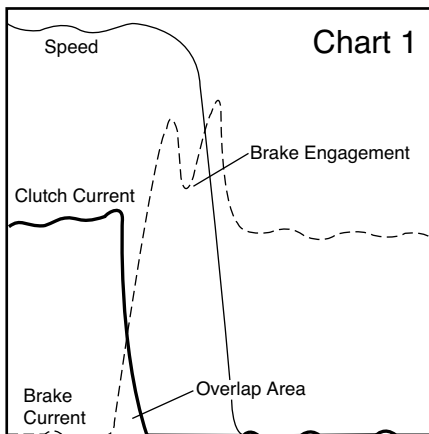

## Brake Engagement with Zener Diode Suppression

Clutch current decay and brake current rise overlap, but the brake armature is not engaged until well past the overlap point. Note that the “blip” in the brake current trace coincides with the sharp decline in the “speed” trace, indicating brake armature engagement at that point.

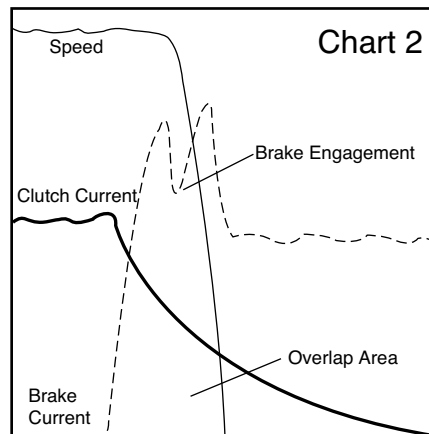

## Brake Engagement with Straight Diode Suppression

Clutch current decay is much slower than with Zener diode suppression as shown in Chart 1, greatly increasing the overlap area. The current level in the clutch coil is much higher at the point of brake engagement than with Zener diode suppression.

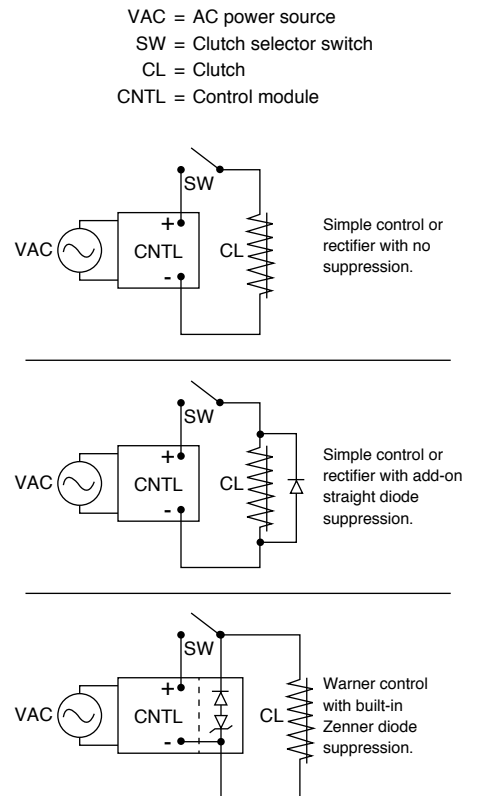

Overexcitation is a technique which makes a clutch or brake engage faster and have greatly improved starting and stopping accuracy. It involves applying over voltage to the clutch or brake coil to reduce current build up time, thereby reducing the magnetizing time.

The graphs below show current rise and shaft speed for an identical system using a Warner Electric EP-400 clutch/brake both with and without overexcitation. The effect of overexcitation is to reduce the time needed to achieve full current and thereby reduce the time required to achieve full speed with a clutch or zero speed with a brake. In the example below, "time to start" is approximate-

ly 70 ms without overexcitation. This is reduced to 30 ms when overexcitation is applied. This time is comparable to the coil buildup times stated on page G-10. The "time to stop" has been similarly reduced; the nominally excited system requires about 110 ms to stop the load, while this is accomplished in only 50 ms with overexcitation.

Overexcitation does not increase torque. Rather, the reduction in start-stop times comes from reduced coil current build up times (or "time to current"). For many common industrial applications, the reduction in "time to speed" and "time to stop" is one half when using overexcitation.

The use of overexcitation on a clutch/brake system does not increase system wear. In fact, the clutch/brake wear rate may be reduced because slippage and energy dissipation is marginally reduced in the clutch/brake. Compliance in the drivetrain may absorb some of the start/stop inertia or wear may be observed in other drivetrain components. Whenever overexcitation is used, adequate coil suppression must be employed. Please refer to "Coil Suppression and Clutch/Brake Overlap" on page G-12.

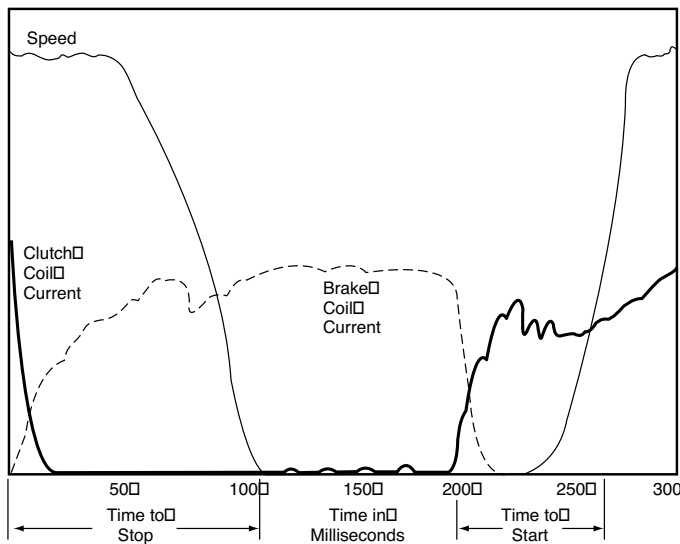

**Chart 1**

### Without Overexcitation

Current/speed trace of EP400 clutch/brake being run through a single stop/start cycle. Note that 110 milliseconds is required to stop from the time the clutch coil is de-energized and the brake coil is energized. At the 200 milliseconds point on the graph the clutch coil is energized and the load is at speed 70 milliseconds later. Note that the coil current is still increasing after the load is at full speed.

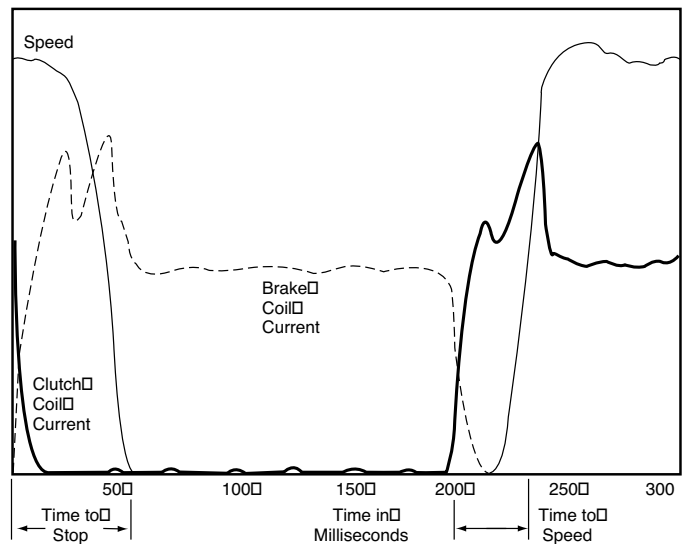

**Chart 2**

### With Overexcitation

Current/speed trace of EP400 clutch/brake being run through a single stop/start cycle. With overexcitation, both brake and clutch coil currents build much faster with concurrent reductions in both stop and start times, when compared with Chart 1.





---

# Bushing Part Numbers



**B**

# Bushing Part Numbers

## Browning® Bushing

Shaft Size	Keyway Size	Bushing Number	
		Warner Electric	Browning
1/2	1/8 x 1/16	180-0002	
9/16	1/8 x 1/16	180-0003	
5/8	3/16 x 3/32	180-0004	
11/16	3/16 x 3/32	180-0005	
3/4	3/16 x 3/32	180-0006	
13/16	3/16 x 3/32	180-0007	
7/8	3/16 x 3/32	180-0008	
15/16	1/4 x 1/8	180-0009	
1	1/4 x 1/8	180-0010	
1 1/16	1/4 x 1/8	180-0011	
1 1/8	1/4 x 1/8	180-0012	
1 3/16	1/4 x 1/8	180-0013	
1 1/4	1/4 x 1/8	180-0014	
1 5/16	5/16 x 5/32	180-0015	
1 3/8	5/16 x 5/32	180-0016	
1 7/16	3/8 x 3/16	180-0017	
1 1/2	3/8 x 3/16	180-0018	
3/4	3/16 x 3/32	180-0026	
13/16	3/16 x 3/32	180-0027	
7/8	3/16 x 3/32	180-0028	
15/16	1/4 x 1/8	180-0029	
1	1/4 x 1/8	180-0030	
1 1/16	1/4 x 1/8	180-0031	
1 1/8	1/4 x 1/8	180-0032	
1 3/16	1/4 x 1/8	180-0033	
1 1/4	1/4 x 1/8	180-0034	
1 5/16	5/16 x 5/32	180-0035	
1 3/8	5/16 x 5/32	180-0036	
1 7/16	3/8 x 3/16	180-0037	
1 1/2	3/8 x 3/16	180-0038	
1 9/16	3/8 x 3/16	180-0039	
1 5/8	3/8 x 3/16	180-0040	
1 11/16	3/8 x 3/16	180-0041	
1 3/4	3/8 x 3/16	180-0042	
1 13/16	1/2 x 1/4	180-0043	
1 7/8	1/2 x 1/4	180-0044	
1 15/16	1/2 x 1/4	180-0045	
2	1/2 x 1/4	180-0046	
2 1/16	1/2 x 1/4	180-0047	
2 1/8	1/2 x 1/4	180-0048	
2 3/16	1/2 x 1/4	180-0049	
2 1/4	1/2 x 1/4	180-0050	
2 5/16	5/8 x 5/16	180-0051	
2 3/8	5/8 x 5/16	180-0052	
2 7/16	5/8 x 5/16	180-0053	
2 1/2	5/8 x 5/16	180-0054	
2 9/16	5/8 x 5/16	180-0055	
2 5/8	5/8 x 5/16	180-0056	
2 11/16	5/8 x 5/16	180-0057	

(Browning® is registered to Emerson Electric Co.)

## Dodge Bushing

Shaft Size	Keyway Size	Bushing Number	
		Warner Electric	Dodge
1/2	1/8 x 1/16	180-0101	
9/16	1/8 x 1/16	180-0102	
5/8	3/16 x 3/32	180-0103	
11/16	3/16 x 3/32	180-0104	
3/4	3/16 x 3/32	180-0105	
13/16	3/16 x 3/32	180-0106	
7/8	3/16 x 3/32	180-0107	1210
15/16	1/4 x 1/8	180-0108	
1	1/4 x 1/8	180-0109	
1 1/16	1/4 x 1/8	180-0110	
1 1/8	1/4 x 1/8	180-0111	
1 3/16	1/4 x 1/8	180-0112	
1 1/4	1/4 x 1/8	180-0113	
1/2	1/8 x 1/16	180-0116	
9/16	1/8 x 1/16	180-0117	
5/8	3/16 x 3/32	180-0118	
11/16	3/16 x 3/32	180-0119	
3/4	3/16 x 3/32	180-0120	
13/16	3/16 x 3/32	180-0121	
7/8	3/16 x 3/32	180-0122	1215
15/16	1/4 x 1/8	180-0123	
1	1/4 x 1/8	180-0124	
1 1/16	1/4 x 1/8	180-0125	
1 1/8	1/4 x 1/8	180-0126	
1 3/16	1/4 x 1/8	180-0127	
1 1/4	1/4 x 1/8	180-0128	
1/2	1/8 x 1/16	180-0131	
9/16	1/8 x 1/16	180-0132	
5/8	3/16 x 3/32	180-0133	
11/16	3/16 x 3/32	180-0134	
3/4	3/16 x 3/32	180-0135	
13/16	3/16 x 3/32	180-0136	
7/8	3/16 x 3/32	180-0137	
15/16	1/4 x 1/8	180-0138	
1	1/4 x 1/8	180-0139	
1 1/16	1/4 x 1/8	180-0140	1615
1 1/8	1/4 x 1/8	180-0141	
1 3/16	1/4 x 1/8	180-0142	
1 1/4	1/4 x 1/8	180-0143	
1 5/16	5/16 x 5/32	180-0144	
1 3/8	5/16 x 5/32	180-0145	
1 7/16	3/8 x 3/16	180-0146	
1 1/2	3/8 x 3/16	180-0147	
1 9/16	3/8 x 3/16	180-0148	
1 5/8	3/8 x 3/16	180-0149	
1/2	1/8 x 1/16	180-0155	
9/16	1/8 x 1/16	180-0156	
5/8	3/16 x 3/32	180-0157	
11/16	3/16 x 3/32	180-0158	
3/4	3/16 x 3/32	180-0159	
13/16	3/16 x 3/32	180-0160	
7/8	3/16 x 3/32	180-0161	2012
15/16	1/4 x 1/8	180-0162	
1	1/4 x 1/8	180-0163	
1 1/16	1/4 x 1/8	180-0164	
1 1/8	1/4 x 1/8	180-0165	
1 3/16	1/4 x 1/8	180-0166	
1 1/4	1/4 x 1/8	180-0167	

# Bushing Part Numbers

## Dodge Bushing

Bushing Number				Bushing Number				Bushing Number			
Shaft Size	Keyway Size	Warner Electric	Dodge	Shaft Size	Keyway Size	Warner Electric	Dodge	Shaft Size	Keyway Size	Warner Electric	Dodge
15/16	5/16 x 5/32	180-0168		11 1/16	3/8 x 3/16	180-0235		1/2	1/8 x 1/16	180-0326	
13/8	5/16 x 5/32	180-0169		13/4	3/8 x 3/16	180-0236		9/16	1/8 x 1/16	180-0327	
17/16	3/8 x 3/16	180-0170		113/16	1/2 x 1/4	180-0237		5/8	3/16 x 3/32	180-0328	
1 1/2	3/8 x 3/16	180-0171		17/8	1/2 x 1/4	180-0238		11/16	3/16 x 3/32	180-0329	
19/16	3/8 x 3/16	180-0172		115/16	1/2 x 1/4	180-0239		3/4	3/16 x 3/32	180-0330	
15/8	3/8 x 3/16	180-0173		2	1/2 x 1/4	180-0240		13/16	3/16 x 3/32	180-0331	
111/16	3/8 x 3/16	180-0174	2012	21/16	1/2 x 1/4	180-0241		7/8	3/16 x 3/32	180-0332	
13/4	3/8 x 3/16	180-0175		21/8	1/2 x 1/4	180-0242		15/16	1/4 x 1/8	180-0333	
113/16	1/2 x 1/4	180-0176		23/16	1/2 x 1/4	180-0243		1	1/4 x 1/8	180-0334	
17/8	1/2 x 1/4	180-0177		21/4	1/2 x 1/4	180-0244		11/16	1/4 x 1/8	180-0335	1610
115/16	1/2 x 1/4	180-0178		25/16	5/8 x 5/16	180-0245		11/8	1/4 x 1/8	180-0336	
2	1/2 x 1/4	180-0179		23/8	5/8 x 5/16	180-0246	3020	13/16	1/4 x 1/8	180-0337	
1/2	1/8 x 1/16	180-0185		27/16	5/8 x 5/16	180-0247		11/4	1/4 x 1/8	180-0338	
9/16	1/8 x 1/16	180-0186		21/2	5/8 x 5/16	180-0248		15/16	5/16 x 5/32	180-0339	
5/8	3/16 x 3/32	180-0187		29/16	5/8 x 5/16	180-0249		13/8	5/16 x 5/32	180-0340	
11/16	3/16 x 3/32	180-0188		25/8	5/8 x 5/16	180-0250		17/16	3/8 x 3/16	180-0341	
3/4	3/16 x 3/32	180-0189		211/16	5/8 x 5/16	180-0251		11/2	3/8 x 3/16	180-0342	
13/16	3/16 x 3/32	180-0190		23/4	5/8 x 5/16	180-0252		19/16	3/8 x 3/16	180-0343	
7/8	3/16 x 3/32	180-0191		213/16	3/4 x 3/8	180-0253		15/8	3/8 x 3/16	180-0344	
15/16	1/4 x 1/8	180-0192		27/8	3/4 x 3/8	180-0254		1/2	1/8 x 1/16	180-0410	
1	1/4 x 1/8	180-0193		215/16	3/4 x 3/8	180-0255		9/16	1/8 x 1/16	180-0411	
11/16	1/4 x 1/8	180-0194		3	3/4 x 3/8	180-0256		5/8	3/16 x 3/32	180-0412	
11/8	1/4 x 1/8	180-0195		15/16	1/4 x 1/8	180-0262		11/16	3/16 x 3/32	180-0413	
13/16	1/4 x 1/8	180-0196		1	1/4 x 1/8	180-0263		3/4	3/16 x 3/32	180-0414	1008
11/4	1/4 x 1/8	180-0197		11/16	1/4 x 1/8	180-0264		3/16	3/16 x 3/32	180-0415	
15/16	5/16 x 5/32	180-0198		11/8	1/4 x 1/8	180-0265		7/8	3/16 x 3/32	180-0416	
13/8	5/16 x 5/32	180-0199		13/16	1/4 x 1/8	180-0266		15/16	1/4 x 1/8	180-0417	
17/16	3/8 x 3/16	180-0200		11/4	1/4 x 1/8	180-0267		1	1/4 x 1/8	180-0418	
1 1/2	3/8 x 3/16	180-0201	2517	15/16	5/16 x 5/32	180-0268		1/2	1/8 x 1/16	180-0421	
19/16	3/8 x 3/16	180-0202		13/8	5/16 x 5/32	180-0269		9/16	1/8 x 1/16	180-0422	
15/8	3/8 x 3/16	180-0203		17/16	3/8 x 3/16	180-0270		5/8	3/16 x 3/32	180-0423	
111/16	3/8 x 3/16	180-0204		11/2	3/8 x 3/16	180-0271		11/16	3/16 x 3/32	180-0424	
13/4	3/8 x 3/16	180-0205		19/16	3/8 x 3/16	180-0272		3/4	3/16 x 3/32	180-0425	
113/16	1/2 x 1/4	180-0206		15/8	3/8 x 3/16	180-0273		13/16	3/16 x 3/32	180-0426	
17/8	1/2 x 1/4	180-0207		111/16	3/8 x 3/16	180-0274		7/8	3/16 x 3/32	180-0427	
115/16	1/2 x 1/4	180-0208		13/4	3/8 x 3/16	180-0275		15/16	1/4 x 1/16	180-0428	1310
2	1/2 x 1/4	180-0209		113/16	1/2 x 1/4	180-0276		1	1/4 x 1/8	180-0429	
21/16	1/2 x 1/4	180-0210		17/8	1/2 x 1/4	180-0277		11/16	1/4 x 1/8	180-0430	
21/8	1/2 x 1/4	180-0211		115/16	1/2 x 1/4	180-0278		11/8	1/4 x 1/8	180-0431	
23/16	1/2 x 1/4	180-0212		2	1/2 x 1/4	180-0279	3030	13/16	1/4 x 1/8	180-0432	
21/4	1/2 x 1/4	180-0213		21/16	1/2 x 1/4	180-0280		11/4	1/4 x 1/8	180-0433	
25/16	5/8 x 5/16	180-0214		21/8	1/2 x 1/4	180-0281		15/16	5/16 x 5/32	180-0434	
23/8	5/8 x 5/16	180-0215		23/16	1/2 x 1/4	180-0282		13/8	5/16 x 5/32	180-0435	
27/16	5/8 x 5/16	180-0216		21/4	1/2 x 1/4	180-0283					
21/2	5/8 x 5/16	180-0217		215/16	5/8 x 5/16	180-0284					
15/16	1/4 x 1/8	180-0223		23/8	5/8 x 5/16	180-0285					
1	1/4 x 1/8	180-0224		27/16	5/8 x 5/16	180-0286					
11/16	1/4 x 1/8	180-0225		21/2	5/8 x 5/16	180-0287					
11/8	1/4 x 1/8	180-0226		29/16	5/8 x 5/16	180-0288					
13/16	1/4 x 1/8	180-0227		25/8	5/8 x 5/16	180-0289					
11/4	1/4 x 1/8	180-0228		211/16	5/8 x 5/16	180-0290					
15/16	5/16 x 5/32	180-0229	3020	23/4	5/8 x 5/16	180-0291					
13/8	5/16 x 5/32	180-0230		213/16	3/4 x 3/8	180-0292					
17/16	3/8 x 3/16	180-0231		27/8	3/4 x 3/8	180-0293					
1 1/2	3/8 x 3/16	180-0232		215/16	3/4 x 3/8	180-0294					
19/16	3/8 x 3/16	180-0233		3	3/4 x 3/8	180-0295					
15/8	3/8 x 3/16	180-0234									

# Notes

---

---

---

---

---

---

---

---

---

---

---

---

---

---

---

---

---

---

---

---

---

---

---

---

---

---

---

---

---

---

---



# Notes

---

Warner Electric's electronic controls are designed to provide simple setup and maximum performance when used with electric clutches and brakes. Our controls offer a range of functions from on-off to torque control to over-excitation.

### Selection

Many parameters beyond function can impact control selection. Warner Electric produces a variety of control options to suit numerous application requirements. Control selection parameters include:

- Mounting Location – Panel or conduit box mounting
- Switching – Relay switching of A.C. or D.C. lines or solid state switching
- Output Voltage – Controls are available for 6, 24 and 90 VDC clutch/brake coils
- Input Voltage – Controls with input power transformers are available for connection to high voltage mains.

If your application requires something special, please call us. We will be happy to provide solutions.

### Clutch and Brake Controls . . . . . CTL-2

#### On-Off Controls

CBC-100 . . . . .	CTL-4
CBC-150 . . . . .	CTL-4
CBC-160 . . . . .	CTL-5
CBC-801 . . . . .	CTL-6
CBC-802 . . . . .	CTL-7

#### Adjustable Torque Controls

MCS-103-1 . . . . .	CTL-8
MCS-805-1 . . . . .	CTL-9
MCS-805-2 . . . . .	CTL-9
CBC-300 . . . . .	CTL-10
CBC-500 . . . . .	CTL-12
CBC-550 . . . . .	CTL-14
CBC-1825R . . . . .	CTL-16

#### Overexcitation Controls

CBC-700 . . . . .	CTL-18
CBC-750 . . . . .	CTL-20

#### Appendix . . . . . CTL-22

#### Questions & Answers . . . . . CTL-23

#### Ordering Information . . . . . CTL-24





# Clutch and Brake Controls

## Functions

### On-Off (Basic start-stop)

Many applications are controlled by energizing the clutches and brakes with their rated D.C. voltages. Warner Electric controls are available with various mounting, input voltage and switching options.

### Adjustable Torque

#### (Soft start-stop)

The torque transmitted by a clutch or brake is proportional to the coil current. Warner Electric offers several products that provide torque control for smooth and repeatable starts and stops.

### Adjustable Accel-Decel

#### (Soft start-stop with full torque)

Warner Electric offers a control that allows for adjustment of the acceleration and deceleration time ramps to achieve a repeatable soft start or stop while still allowing for full torque.

### Overexcitation

#### (Rapid cycling)

The clutch/brake speed of response can be increased for improved accuracy and performance through overexcitation, which is the application of a short high voltage pulse to provide nearly instantaneous torque.

#### Control Type

#### On-Off Conduit Box Mount



#### On-Off Octal Socket Mount



#### Adjustable Torque



#### Adjustable Accel-Decel

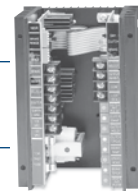

#### Overexcitation

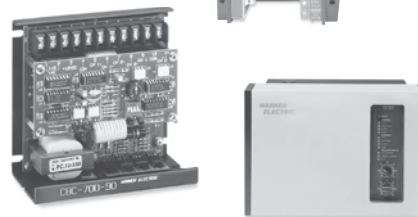

# Clutch and Brake Controls

Model Number	No. of Channels	Torque Control Channels	A.C. Input Voltages	D.C. Output Voltages	Over-Excitation	Customer Supplied Switching Options	Description	Page Number
CBC-100-1	1	No	120	90	No	Relay A.C.	Single channel control to mount inside standard conduit box	CTL-4
CBC-100-2	1	No	220/240					
CBC-150-1	2	No	120	90	No	Relay A.C.	Dual channel control for clutch/brake to mount inside module conduit box	CTL-4
CBC-150-2	2	No	220/240					
CBC-160-1	1	1	120	90	No	Relay A.C.	Single channel control with torque adjust for module electrically released brakes	CTL-5
CBC-160-2			220/240					
CBC-801-1	2	No	120	90	No	Relay D.C.	Dual channel control for 2 clutches and/or brakes	CTL-6
CBC-801-2	2		220/240					
CBC-802	2	No	120	90	No	Transistor or Relay D.C.	Dual channel control with transistor switching	CTL-7
MCS-103-1	2	1	120	90	No	Relay D.C.	Dual channel control with torque adjust for one channel	CTL-8
MCS-805-1	1	1	120/240	35-75	No	Relay D.C.	Single adjustable channel control for use with ER-1225 brake.	CTL-9
MCS-805-2								
CBC-300	2	2	120	90	No	Transistor or Relay D.C.	Dual channel adjustable current control	CTL-10 to CTL-11
CBC-300-1								
CBC-500-90	2	2	120	90	No	Transistor or Relay D.C.	Dual channel control for two clutches and/or brakes with two torque adjust channels; Emergency stop input	CTL-12 to CTL-15
CBC-500-24	2	2	24-30	24	No			
CBC-550-90	2	2	120/220/240/380/480	90	No			
CBC-550-24	2	2	120/220/240/380/480	24	No			
CBC-1825-R	2	2	120	90	No	Transistor or Relay D.C.	Dual channel adjustable time ramp with short circuit protection	CTL-16 to CTL-17
CBC-700-90	2	No	120	90	Yes	Transistor or Relay D.C.	Dual channel compact overexcitation control for 24 or 90 volt clutches and brakes	CTL-18 to CTL-19
CBC-700-24	2		24-28	24				
CBC-750-6	2	2	120/220/240	6	Yes	Transistor, Relay D.C. or Triac A.C.	Dual channel full function overexcitation control; provides input/output logic, torque adjustable current and remote inputs	CTL-20 to CTL-21

# CBC-100/CBC-150 On-Off Controls

## Integral/Conduit Box Mounted Controls

The CBC-100 and CBC-150 series are UL listed, conduit box mounted controls for 90 volt clutches and brakes. Models are available for either 120 VAC or 220/240 VAC input.



### CBC-100 series Single unit capacity

The CBC-100 mounts inside a standard Warner Electric conduit box and includes rectification and suppression circuits.

- cULus
- Compact
- Single channel
- Mounts inside conduit box



### CBC-150 series Dual channel capacity

The CBC-150 replaces the cover on the standard module conduit box (part no. 5370-101-042). Provides rectification and suppression for two devices. Green LED indicates power to clutch. Red LED indicates power to brake.

- cULus
- Dual channel
- Replaces the cover on the module conduit box

## Specifications

	CBC-100-1	CBC-100-2	CBC-150-1	CBC-150-2
Part No.	6003-448-101	6003-448-103	6004-448-001	6004-448-002
Input	120 VAC 50/60 Hz	220/240 VAC 50/60 Hz	120 VAC 50/60 Hz	220/240 VAC 50/60 Hz
Output	90 VDC full wave rectified .8 Amp max.	90 VDC half wave .8 Amp	90 VDC full wave rectified Dual .8 Amp	90 VDC half wave Dual .8 Amp
Ambient Temperatures	-20° to 113°F (-29° to 45°C)			
Switching	External to control, accomplished on A.C. line using relay or triac.			
	SPST	SPST	SPDT	SPDT
Solid State (maximum leakage current <2 mA)	140 VAC, 1 Amp min.	280 VAC, 1 Amp min.	140 VAC, 2 Amp min.	280 VAC, 2 Amp min.
Electro-mechanical	120 VAC, 1 Amp min.	240 VAC, 1 Amp min.	120 VAC, 1 Amp min.	240 VAC, 1 Amp min.

## Connection diagrams

### CBC-100-1, -2

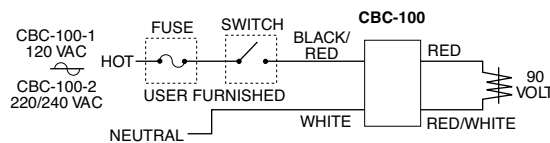

## Dimensions

### CBC-100-1, -2

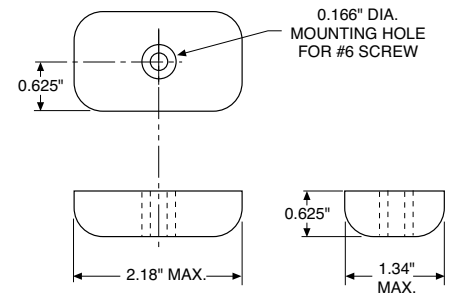

### CBC-150-1, -2

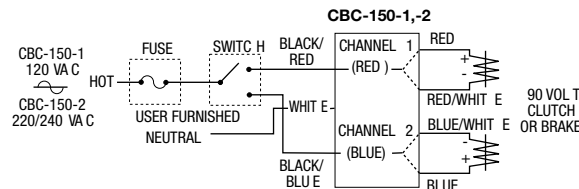

### CBC-150-1, -2

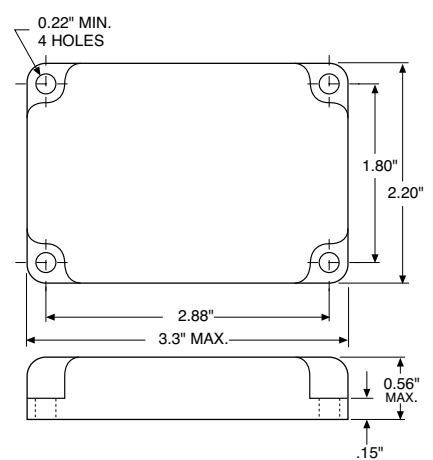

All dimensions nominal unless otherwise specified.

## Integral/Electrically Released Motor Brake Controls

### CBC-160

The CBC-160 series clutch/brake controls provide a single 90 VDC adjustable output for use with any clutch/brake unit. The adjustable output will provide consistent and repeatable release for Warner Electric's 90 VDC permanent magnet electrically released brakes. The CBC-160 mounts as the cover on the standard module conduit box (part number: 5370-101-042).



### CBC-160-1

The 160-1 accommodates 120 volts A.C. motors.

- cULus
- Adjustable 30-100 VDC
- LED indicator
- 120 volt A.C. input

### CBC-160-2

The power to the 160-2 control can come from either a 230 volt or 460 volt A.C. motor. Customer-provided switching is accomplished through the motor starter on the A.C. input. This allows convenient retrofit of spring-set style motor brakes and inexpensive installation of new applications.

- cULus
- Adjustable 30-100 VDC
- Power from motor
- Easy retrofit
- 230/460 motors

### Dimensions

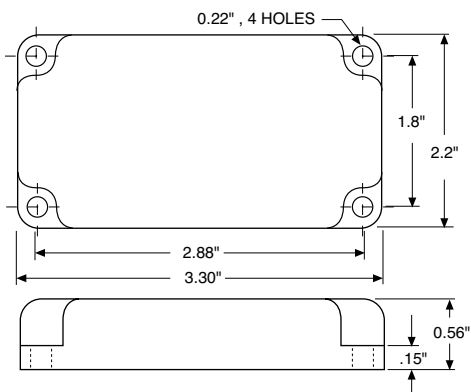

All dimensions nominal unless otherwise specified.

### Specifications

	CBC-160-1	CBC-160-2
Part No.	6013-448-001	6013-448-002
Input	120 VAC, 50/60 Hz	220/240 VAC, 60 Hz, 1 Phase, 100 VA max.
Status Indicator	Red LED indicates power to the brake	—
Output	Single Channel, 30-100 VDC half-wave rectified nominal, 0.8 Amps maximum	
Ambient Temperatures	0° to 122°F (-18° to 50°C)	
Switching	Accomplished through motor starter or on A.C. line using relay or triac	

### Connection Diagrams

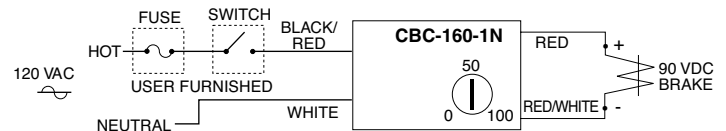

### WYE Connected Motor

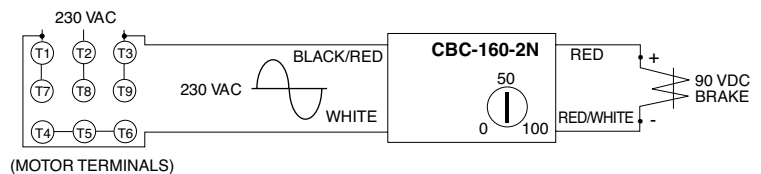
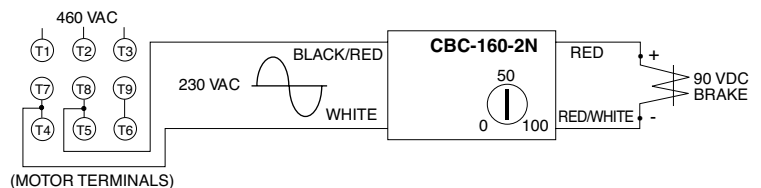

### DELTA Connected Motor

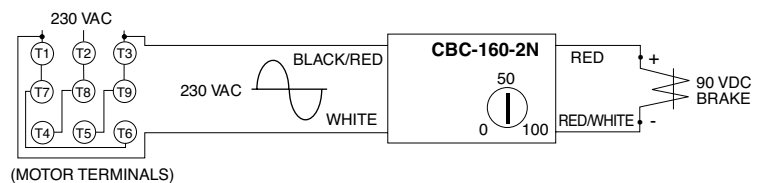
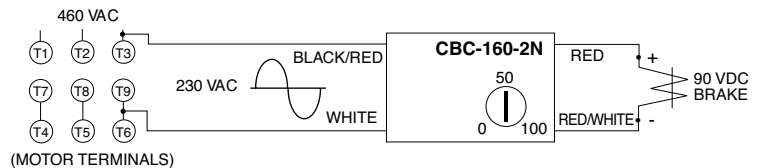

# CBC-801 On-Off Controls

## Plug-in Octal Socket Power Supplies

The CBC-801 is a basic on-off power supply that provides full voltage to a 90 volt clutch or brake and is activated by an external switch. This type of power supply is sufficient for many clutch/brake applications.

### CBC-801 series Multi-unit capacity

The CBC-801 is a plug-in power supply which is used with an octal socket. The wiring connections are made at the socket. The CBC-801 will operate two units separately—or simultaneously. Octal socket is purchased separately.

### Dimensions

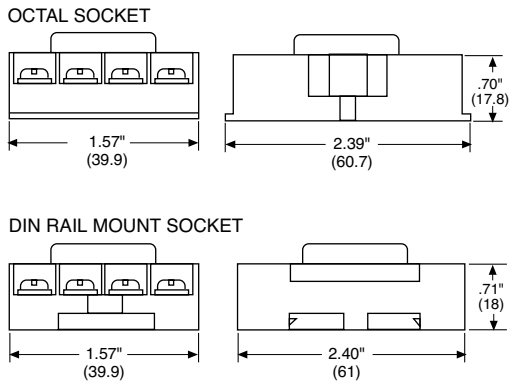
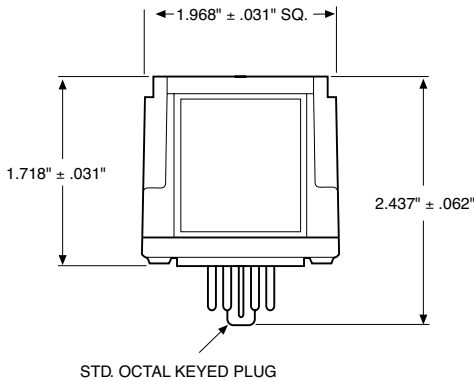

All dimensions nominal unless otherwise specified.

- cULus
- For basic on-off operation
- Wiring connections made at octal socket
- Arc suppression circuitry extends switch life
- Fused for overload protection
- LED output indicators
- DIN rail mountable



### Specifications

	CBC-801-1	CBC-801-2
Part No.	6001-448-004	6001-448-006
Input Voltage	120 VAC, 50/60 Hz	220/240 VAC, 50/60 Hz
Output	90 VDC, 1.25 A max.	
Circuit Protection	Fused 1.6 Amp, 250 V fast-blo	
Ambient Temperature	-23° to 116°F (-31° to 47°C)	
Max. Cycle Rate	Limited by the clutch or brake, variable with application	
Switching	Single pole, double throw Minimum contact rating: 10 Amp, 28 VDC resistive or 10 Amp, 120 VAC inductive	
Status Indicator	Red LED indicates brake is energized, Green LED indicates clutch is energized	
Mounting	Two versions of octal socket are available: 6001-101-001 foot mount 6001-101-002 DIN rail mount	

### Connection Diagrams

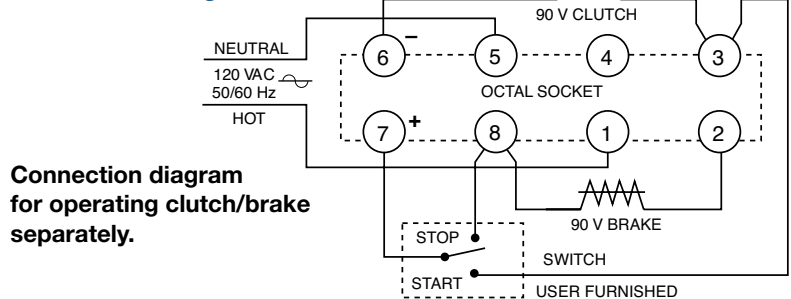

Connection diagram for operating clutch/brake separately.

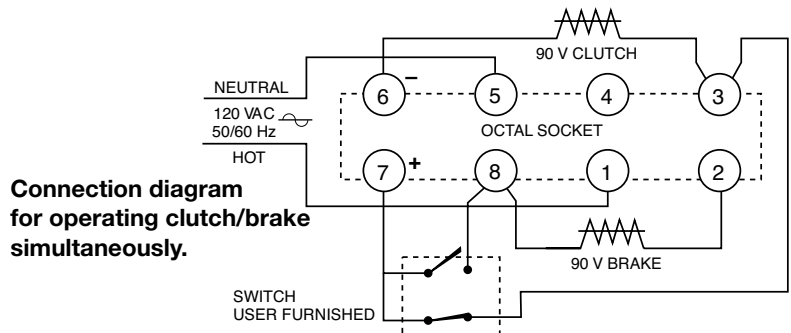

Connection diagram for operating clutch/brake simultaneously.



### CBC-802 PLC compatible

The CBC-802 is a power supply with solid state circuits for load switching. A brake and clutch may be operated separately — or, two brakes or two clutches, one unit on at a time. The CBC-802 mounts on an octal socket (purchased separately), and the wiring connections are made at the socket terminals. Octal socket sold separately, refer to mounting specifications for part number.

- Plug-in power supply with solid state switching circuits—increases switch service life
- Adjustable time delay for controlling clutch/brake overlap
- Internally fused for overload protection
- DIN rail mountable
- LED output indicators

### Dimensions

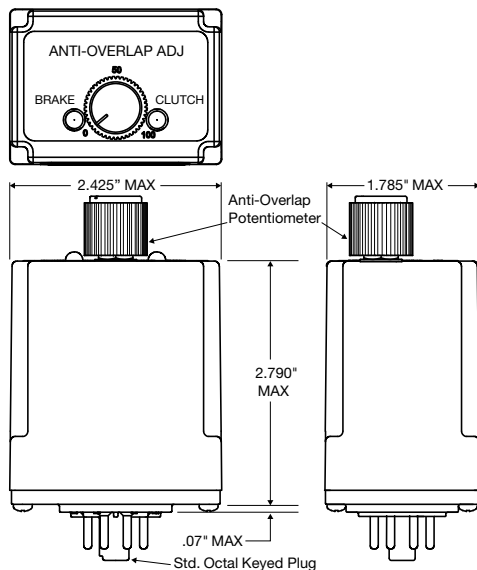

All dimensions nominal unless otherwise specified.

### Specifications

CBC-802	
Part No.	6002-448-002
Input	120 VAC, 50/60 Hz
Output	90 VDC, 0.5 A max.
Status Indicator	Red LED indicates brake energized. Green LED indicates clutch energized.
Circuit Protection	Fused 0.5 Amps, 250 V
Ambient Temperature	-20° to 113°F (-29° to 45°C)
Leakage Current	500 uA max. for solid state switches
Max. Cycle Rate	Limited by the clutch or brake, variable with application
Switching	Momentary contact, maintained contact, or solid state open collector logic Minimum contact rating 20 VDC resistive, 0.01 Amps Minimum input pulse—1 millisecond
Adjustments	Externally adjusted potentiometer sets overlap between clutch and brake from 0 to 130 MS.
Mounting:	Two versions of octal socket are available: 6001-101-001 foot mount 6001-101-002 DIN rail mount

### Connection Diagram

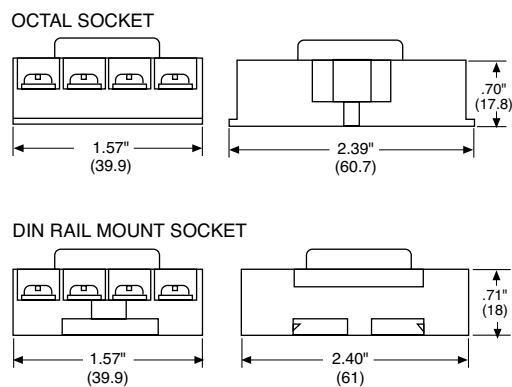
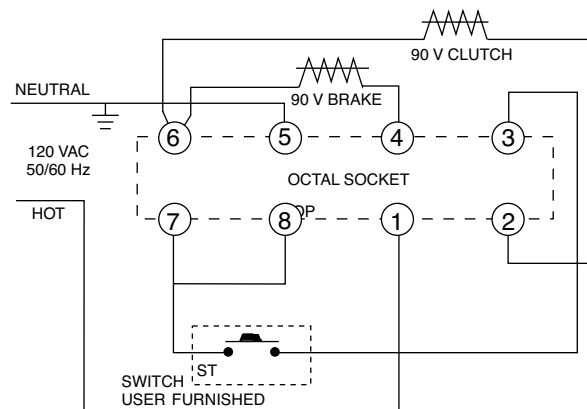



# MCS-103-1 Adjustable Torque Controls

## Adjustable Torque Control

The MCS-103-1 is an enclosed control complete with a cover and mounting provisions. A brake and clutch may be operated separately with this control – or up to four units, two at a time. The external wiring is connected to the terminal strip located behind the cover.

-  Can be used with electrically released brakes

- Torque control for one 90 VDC clutch or brake
- Operates up to four units, two on at a time
- Easy-to-install. Compact. 120 VAC input
- Convenient terminal strip behind an easy-to-remove cover



### Dimensions

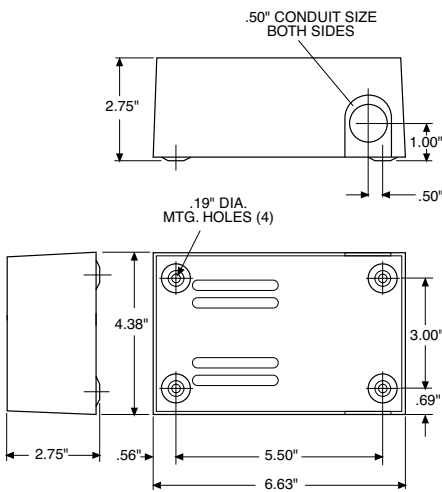

All dimensions nominal unless otherwise specified.

### Specifications

MCS-103-1	
Part No.	6010-448-002
Input	120 VAC, 50/60 Hz
Output	1.25 Amp 90 V full wave rectified for one unit and adjustable from 0-90 volts full wave rectified for second unit
Circuit Protection	Fused 1.5 Amp, 250 V
Ambient Temperature	-20° to 113°F (-29° to 45°C)
Maximum Cycle Rate	Limited by the clutch or brake and will vary with application.
Mounting	Mounting centers 5-1/2" wide, 3" high. Knockouts for 1/2" conduit
External Switches (User furnished)	Double pole, double throw maintained contact. Minimum contact rating: 10 Amp, 28 VDC resistive or 10 Amp, 120 VAC inductive. Contact ratings given will operate all Warner Electric brake and clutch units. However, switches with ratings less than those given may be used with fractional horsepower units provided the rating is equal to or greater than the coil current.

### Connection Diagrams

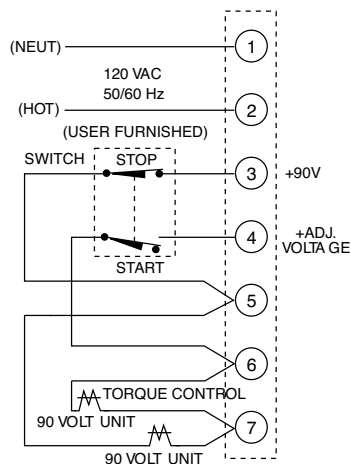

Normal Clutch/Brake Operation  
(One unit on at a time)

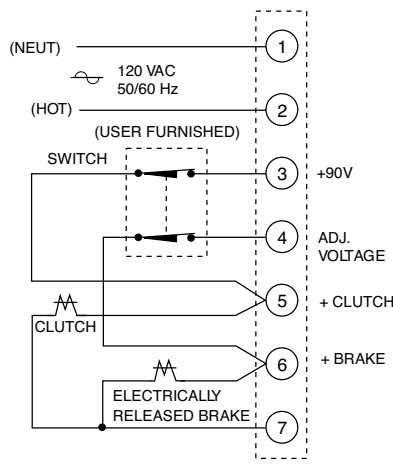

Clutch/Electrically Released  
Brake Operation  
(Both units on at a time)

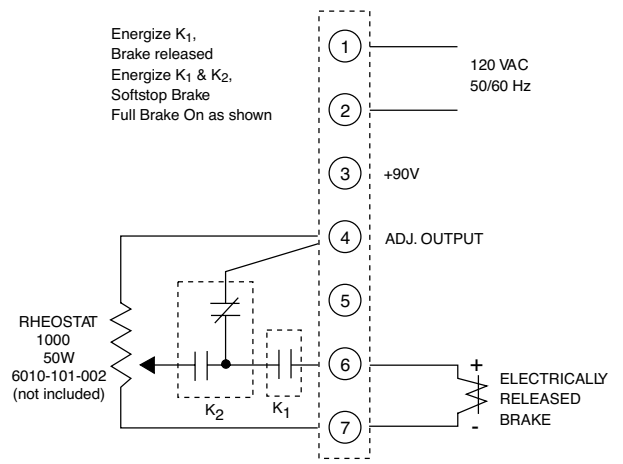

Soft Stop for  
Electrically Released Brake



# MCS-805-1/MCS-805-2 Power Supply

The DC voltage required to release the Warner Electric ER-1225 Brake is supplied by the MCS-805-1 or MCS-805-2 Power Supply. The correct brake release voltage—approximately 35-75 volts DC—is set by adjusting the power supply at the time of brake installation. Temperature compensating circuits provide proper operation over the entire operating range of 0°F to 150°F. Switching may be provided on either the AC or DC side of the power supply. The MCS-805-1 may be mounted on its back panel or on 1/2" conduit. The MCS-805-2 has a torque adjustment capability for soft stop applications. The MCS-805-2 requires two switching circuits when used for those applications requiring soft engagement.



## Specifications

	MCS-805-1	MCS-805-2
Part No.	6090-448-006	6090-448-007
Input	115/230 VAC, 50/60 Hz ±10%	115/230 VAC, 50/60 Hz ±10%
Output	0.4 Amp, 35/75 VDC	0.4 Amp, 35/75 VDC
Ambient Temperature	-20° to 150°F (-29° to 65°C)	-20° to 150°F (-29° to 65°C)
Maximum Cycle Rate	Limited by the clutch or brake and will vary with application. Consult factory for specifics.	
External Switches (User furnished)	For DC switching: single pole, single throw. Minimum contact rating 1 amp, 120 volts DC resistive. For AC switching: single pole, single throw. Minimum contact rating 1 amp, 120 volts AC.	
Circuit Protection	.75 Amp 250V Slow Blow 3 AG	

## Dimensions

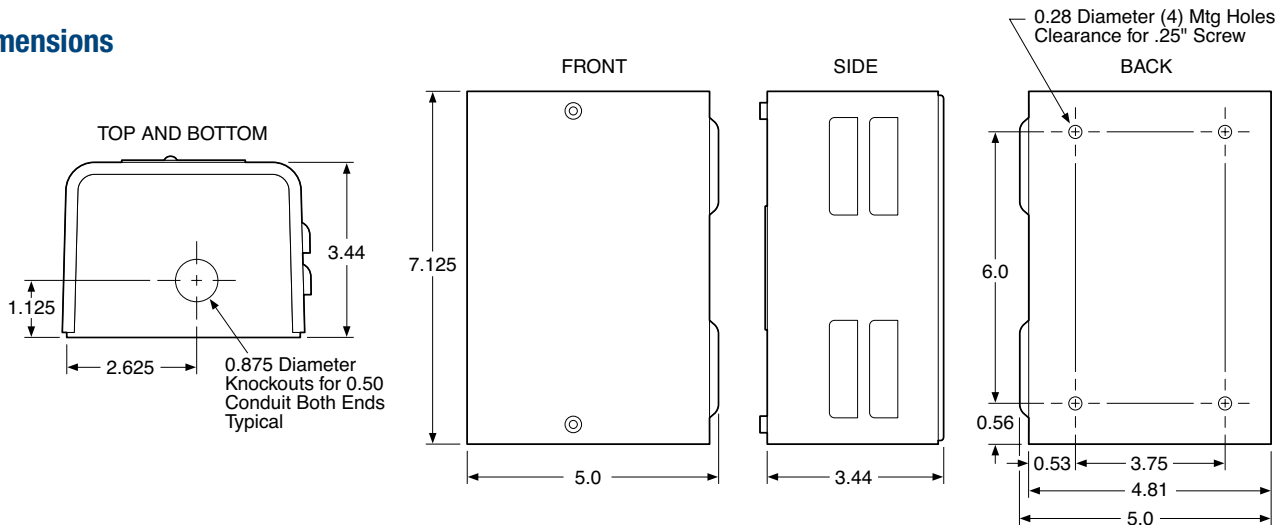

## Connection Diagrams

Connect the MCS-805-1 or MCS-805-2 Power Supply per the following diagram and instructions:

### MCS 805-1

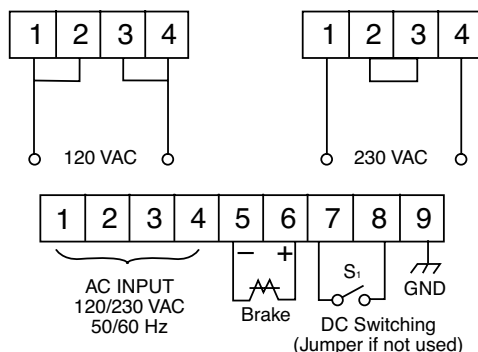

### MCS 805-2

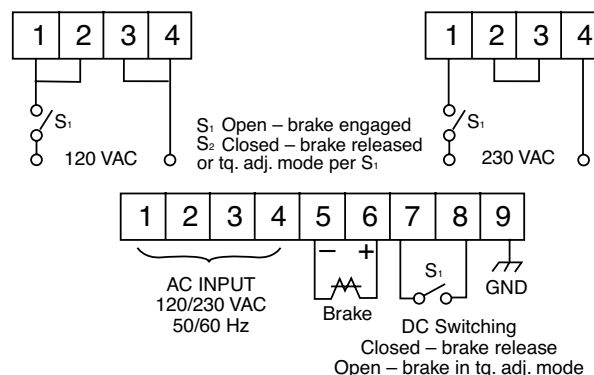

For AC switching, switch may be in series with input supply. For DC switching, use terminals 7 and 8 as shown. DO NOT put switch in series with load on terminals 5 and 6.

# CBC-300 Adjustable Torque Controls

The CBC-300 Series Controls provide dual torque controls when connected to any of Warner Electric's 90 volt clutches and brakes.

-  US
- Current monitored output maintains consistent torque regardless of variation in coil temperature.
- Switch selection tunes control to exactly match current requirements and operating characteristics of each clutch or brake.
- Individual torque adjust allows preset maximum torque tailored to application requirements.
- Short circuit protection, line to line.
- Torque limiting protects machine components from damage.
- Can be used with electrically released brakes.
- Internally Fuse Protected



## CBC-300 Series Dual channel/Dual channel torque adjust

The CBC-300 has two adjustable current channels.

## Specifications

CBC-300													
Part No.	6021-448-009												
Input Power	120 VAC +10% -15%, 50/60 Hz, single phase, 215 VA max.												
Output	Pulse-width modulated full wave rectified D.C. Constant current, switch selectable ranges, 0-90 volt												
Ambient Temperature	+32°F to +113°F (0°C to 45°C) with plastic cover installed +32°F to +150°F (0°C to 66°C) with plastic cover removed												
Circuit Protection	Internal line to line short circuit protection Optional customer supplied fusing on A.C. line, 1.5 Amps, 250 VAC. Fast-acting fuse internal 300 (recommended 300-1)												
Current Adjust (via front panel potentiometers)	Dual adjustable channels												
Status indicators	"POWER"—green LED indicates A.C. power is applied to the control. "SHORT"—red LED indicates a short circuit condition exists on one or both outputs.												
Internal Adjustments	Set DIP switches SW1 and SW2 to suit the current draw of the connected clutch/brake coil: <table border="1"> <thead> <tr> <th>Switch Range</th> <th>1</th> <th>2</th> <th>3</th> <th>4</th> <th>5</th> </tr> </thead> <tbody> <tr> <td>Max Current Draw (mA)</td> <td>60</td> <td>175</td> <td>245</td> <td>305</td> <td>533</td> </tr> </tbody> </table>	Switch Range	1	2	3	4	5	Max Current Draw (mA)	60	175	245	305	533
Switch Range	1	2	3	4	5								
Max Current Draw (mA)	60	175	245	305	533								
External Switching	Mechanical or electromechanical—customer supplied: 1 Amp, 125 V minimum rating Solid-state, NPN isolated transistor—customer supplied: 2 Amp, J250 V minimum rating. Maximum off state leakage current <1 mA												

## Connection Diagram

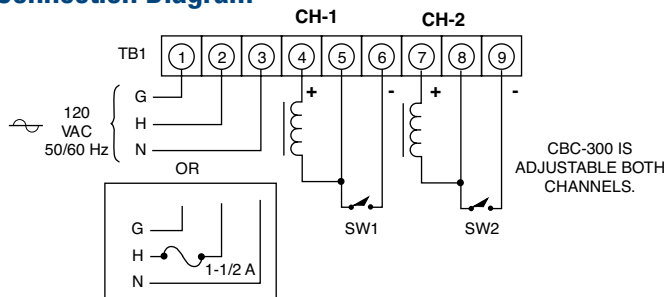

# CBC-300 Adjustable Torque Controls

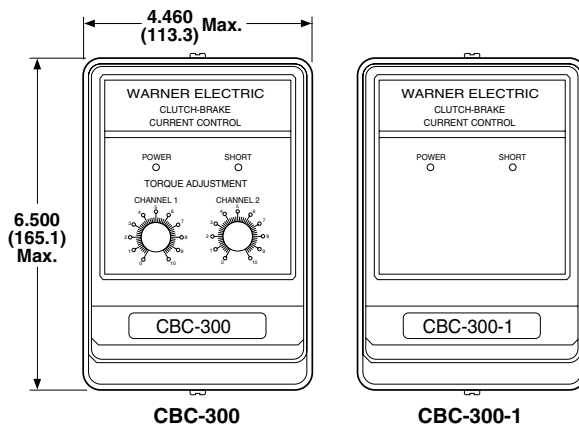
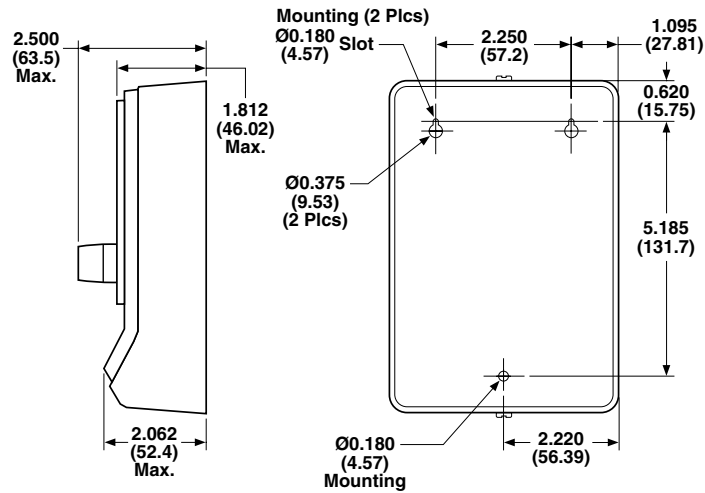

Pots for remote current adjustment: 6011-101-001 single turn  
6011-101-002 ten turn

## Selection Guide

	CBC 300	CBC 300-1
NEMA 1 Enclosure	6021-448-009	6021-448-002
	Both channels adjustable	Both channels adjustable
	Adjustable by knobs on unit	Adjustable by remote pots
	Max. output at 100%	Max. output at 100%

# CBC-500 Adjustable Torque Controls

## Panel Mounted

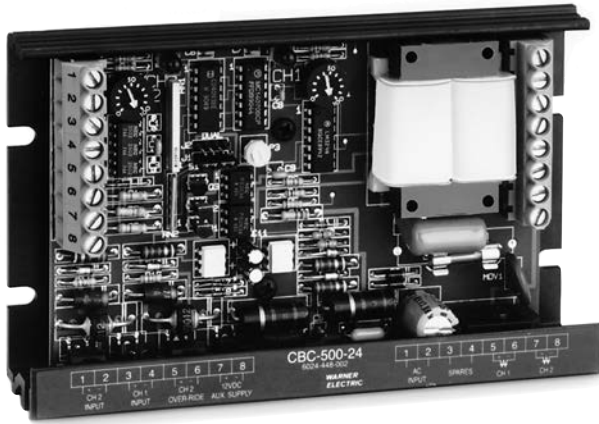

## Specifications

	CBC-500-90	CBC-500-24
Part No.	6024-448-003	6024-448-002
Input Voltage	120 VAC	24-30 VAC or VDC
Output Voltage	0-90 VDC	0-24 VDC
Output Current	1 Amp/Channel 2 Amps Total	5 Amps/Channel 5 Amps Total
Auxiliary Supply	12 VDC 250 mA	12 VDC 250 mA
Circuit Protection	Fused 2.5 Amp, 250 V Fast-blo	Fused 6.3 Amp, 250 V Fast-blo
Ambient Temperature	+32° to 122°F (0° to 50°C)	
Status Indicators	Red LED indicates channel is energized.	
Adjustments	Two potentiometers for voltage adjustment of channel 1 and channel 2 output from 0 to full rated voltage. Frequency adjustment from 60 to 400 Hz to reduce clutch/brake "Hum" associated with machine frequencies. Jumper for single or dual operation. See Appendix for explanation.	
Inputs:	3 Optically coupled, 10-30 VDC, 3-9 mA for Channel 1, Channel 2 and Channel 2 override (applies full voltage to channel 1 output)	

## CBC-500 series Dual torque adjustable power supplies

The CBC-500 series is a dual channel adjustable voltage control with optically isolated input switching for 24 and 90 volt electric clutches and brakes. These controls can be set up to energize the two outputs alternately (single) or simultaneously (dual). Refer to the Appendix for additional setup and switching information.

- Dual adjustable channels
- Optically isolated input switching
- Single or dual channel operation
- Auxiliary 12V supply
- Can be used with electrically released brakes

## Enclosure (Optional)



- Lift off hinge
- Quick-release latches
- Conforms to NEMA Type 13
- European Standard IEC 529, IP65

# CBC-500 Adjustable Torque Controls

Panel Mounted

## Connection Diagram

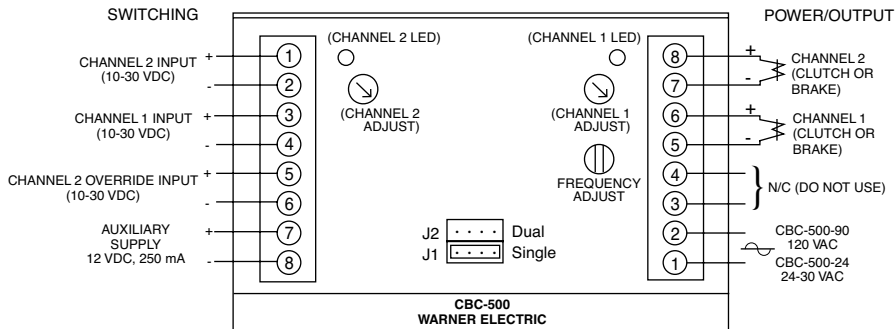

All dimensions nominal unless otherwise specified.

## Dimensions

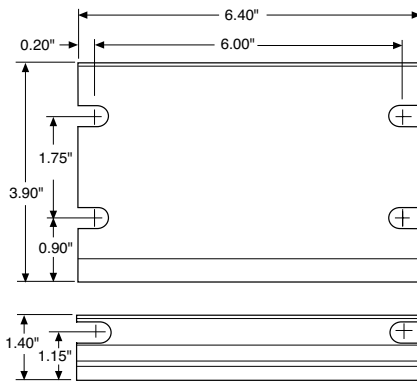

Part No. 6042-101-004

Size 8"H x 6"W x 4"D  
(203.2 x 152.4 x 101.6 mm)

# CBC-550 Adjustable Torque Controls

## Panel Mounted

### CBC-550 series

#### Dual adjustable with power transformer

The CBC-550 series is a dual channel adjustable voltage control with optically coupled switching for 24 and 90 volt electric clutches and brakes. These controls can be set up to energize the two outputs alter-nately (single) or simultaneously (dual). Refer to the Appendix for additional setup and switching information.

The CBC-550 series has a power transformer which will operate with a 120, 220, 240, 380, or 480 VAC input.

- Dual adjustable channels
- Optically isolated input switching
- Single or dual channel operation
- Can be used with electrically released brakes

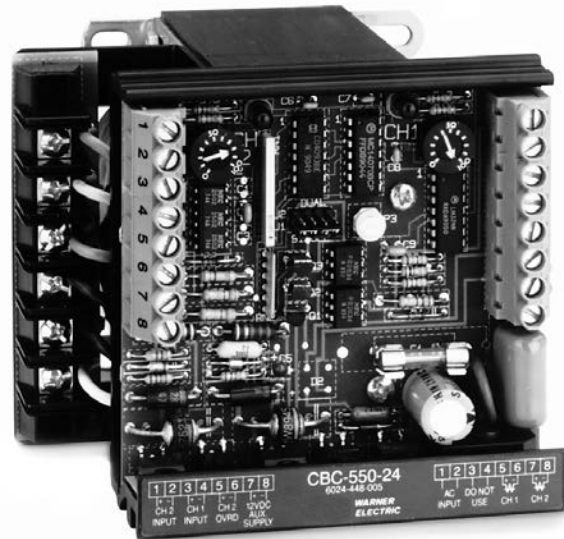

### Specifications

	CBC-550-90	CBC-550-24
Part No.	6024-448-006	6024-448-005
Input Voltage	120/220/240/380/480 VAC	
Output Voltage	0-90 VDC	0-24 VDC
Output Current	1 Amp/Channel 1.2 Amps Total	4 Amps/Channel 4 Amps Total
Auxiliary Supply	12 VDC 250 mA	12 VDC 250 mA
Circuit Protection	Fused 1.5 Amp, 250 V fast-blo	Fused 5 Amp, 250 V fast-blo
Ambient Temperature	+32° to 122°F (0° to 50°C)	
Status Indicators	Red LED indicates channel is energized.	
Adjustments	Two potentiometers for voltage adjustment of channel 1 and channel 2 output from 0 to full rated voltage. Frequency adjustment from 60 to 400 Hz to reduce clutch/brake "Hum" associated with machine frequencies. Jumper for single or dual operation. See Appendix for explanation.	
Inputs	3 Optically coupled, 10-30 VDC, 3-9 mA for Channel 1, Channel 2 and Channel 2 override (applies full voltage to channel 1 output)	

### Enclosure (Optional)



- Lift off hinge
- Quick-release latches
- Conforms to NEMA Type 13
- European Standard IEC 529, IP65

Part No. 6006-101-007

Size 6"H x 6"W x 6"D  
(152.4 x 152.4 x 152.4 mm)

# CBC-550 Adjustable Torque Controls

Panel Mounted

## Dimensions

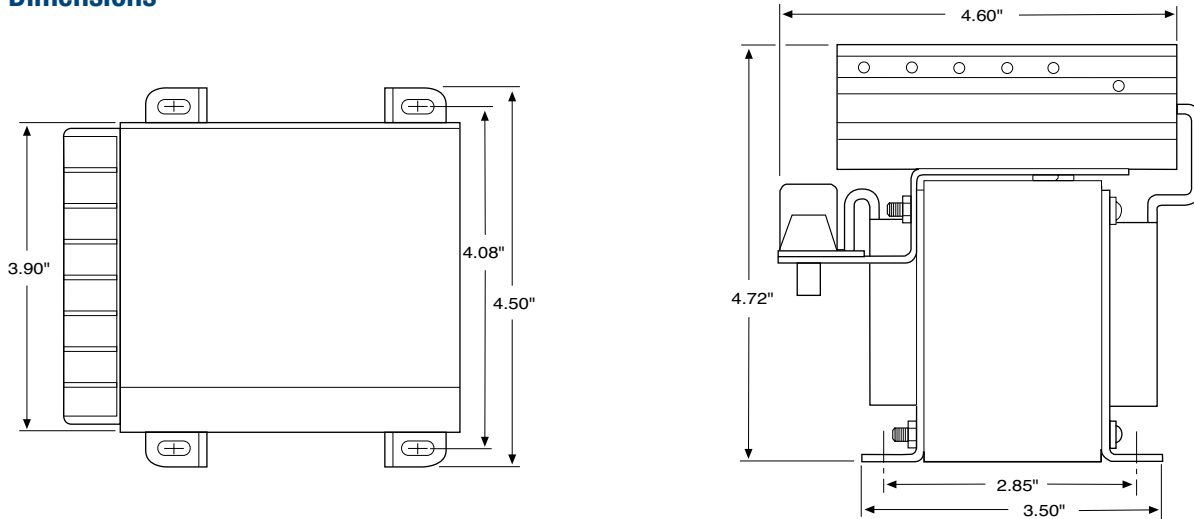

## Connection Diagram

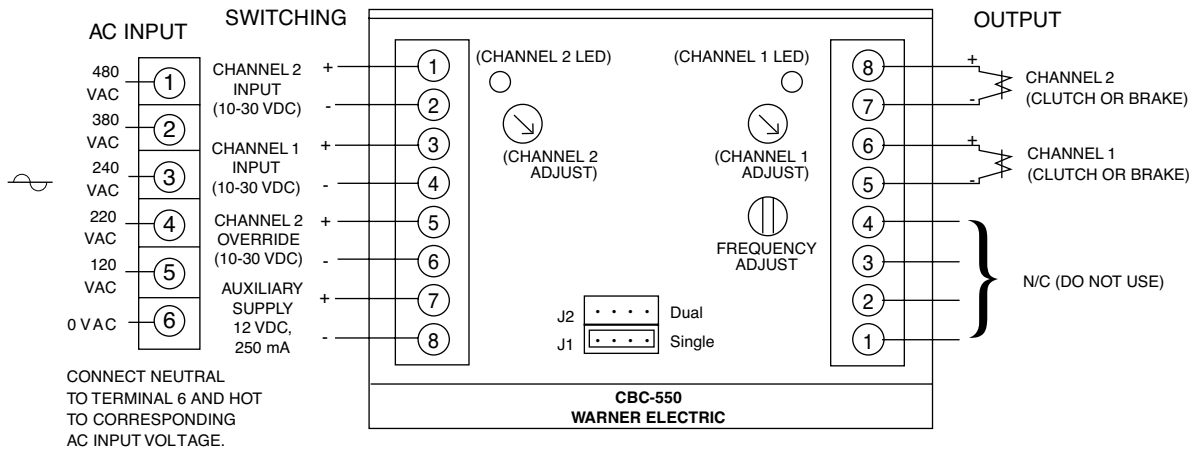

All dimensions nominal unless otherwise specified.



# CBC-1825R Adjustable Torque Controls

## Panel Mounted

### CBC-1825R series

The CBC-1825R is designed to provide consistent and repeatable acceleration and deceleration when used with Warner Electric 90 VDC clutches and brakes. Current to each channel is introduced along an adjustable time ramp and monitored continuously. Adjustments include initial pull-in pulse, hold level, maximum torque, and ramp time. LEDs are provided on the circuit board to indicate power is applied to the clutch or brake unit.

**Note:** It is recommended that the auto-gap springs be removed from the clutch and brake for successful accel-decel application.

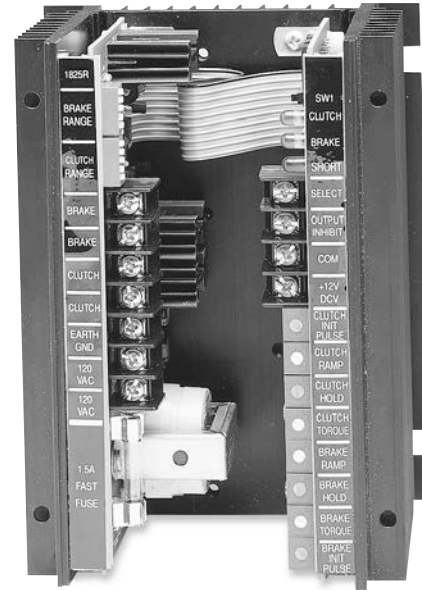

### Specifications

CBC-1825R	
Part No.	1825-448-001
Input Voltage	120 VAC, 50/60 Hz, 100 VA maximum
Output Current	Current driven PWM, compatible with 90 VDC clutch/brake (switch selectable current output)
Auxiliary Supply	12 VDC 250 mA
Circuit Protection	Input Fused 1.5 Amp, 250 V fast-blo clutch and brake outputs are short circuit protected
Status Indicators	Clutch and brake LEDs indicate output is energized Short circuit LED indicates a fault
Ambient Temperature	0° to 122°F (-18° to 50°C)
Switching	Contact rating: 15 mA @ 15 V, open collector NPN 2mA maximum allowable leakage current and 2 V maximum saturation voltage

### Set-up

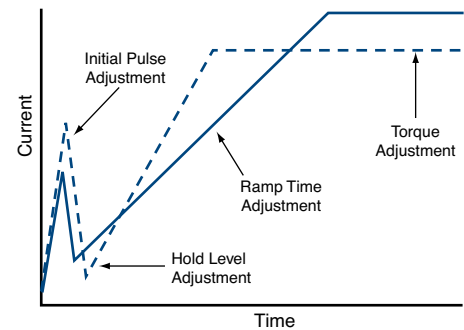

All dimensions nominal unless otherwise specified.

# CBC-1825R Adjustable Torque Controls

Panel Mounted

## Dimensions

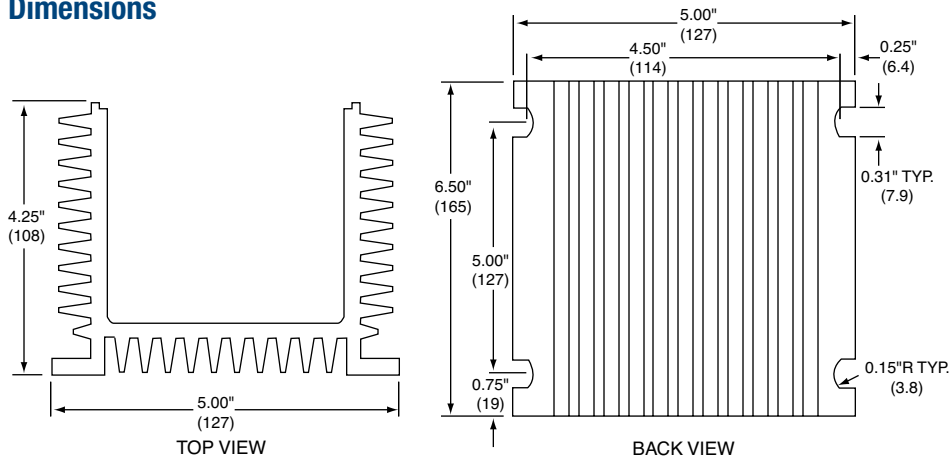

## Connection Diagram

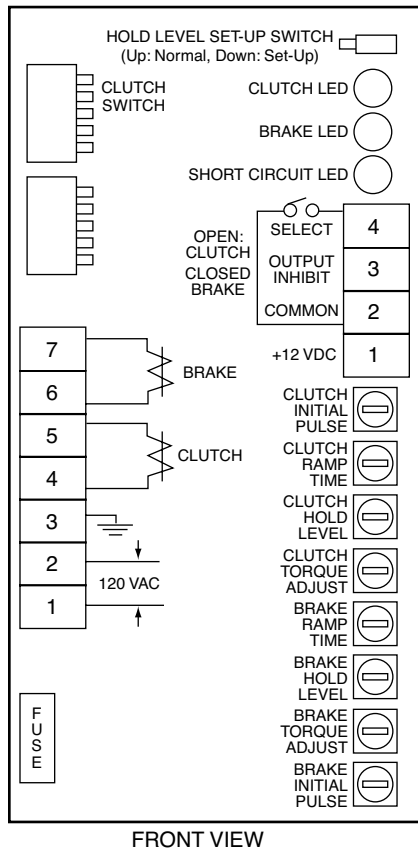

# CBC-700 Overexcitation Controls

## General Purpose OEX Control

### CBC-700 Series

Simple, compact, high performance OEX control for either 90 or 24 VDC clutches and brakes. OEX spike duration and anti-overlap times delay are adjustable. Two optically isolated inputs.

- High performance
- Switch selectable OEX duration
- Force decay suppression with adjustable anti-overlap time delay
- Compact, flexible mounting
- Models for 24 or 90 volt clutches and brakes
- Cycle rate limited by clutch/brake

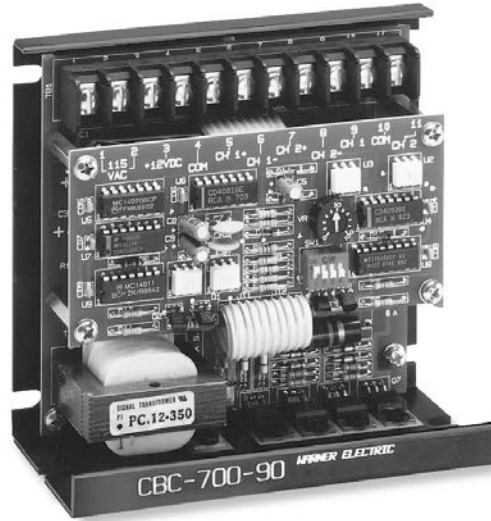

### Specifications

	CBC-700-90	CBC-700-24
Part No.	6042-448-003	6042-448-002
Input	120 VAC, 50/60 Hz	24-28 VAC, 50/60 Hz
Output Voltages		
Steady State	90 VDC	24 VDC
Overexcitation	340 VDC	105 VDC
Output Current (Per channel alternately)	.5 Amps	3.5 Amps
OEX Pulse Duration	Adjustable through logic board dip switches (see service manual)	
Inputs	Two-optically isolated (10-30 VDC)	
Ambient Temperature Range	0°F to 140°F (-18°C to +60°C)	
Maximum Off State Leakage	<2 mA (inputs)	
Circuit Protection	1.6A Fast Act (5 x 20 mm)	5A Slo-Blo (5 x 20 mm)
Auxiliary Supply	12 VDC, 250 mA maximum	

### Enclosure (Optional)



- Lift off hinge
- Quick-release latches
- Conforms to NEMA Type 13
- European Standard IEC 529, IP65

**Part No. 6042-101-004**

Size 8"H x 6"W x 4"D  
(203.2 x 152.4 x 101.6 mm)

# CBC-700 Overexcitation Controls

## General Purpose OEX Control

### Dimensions

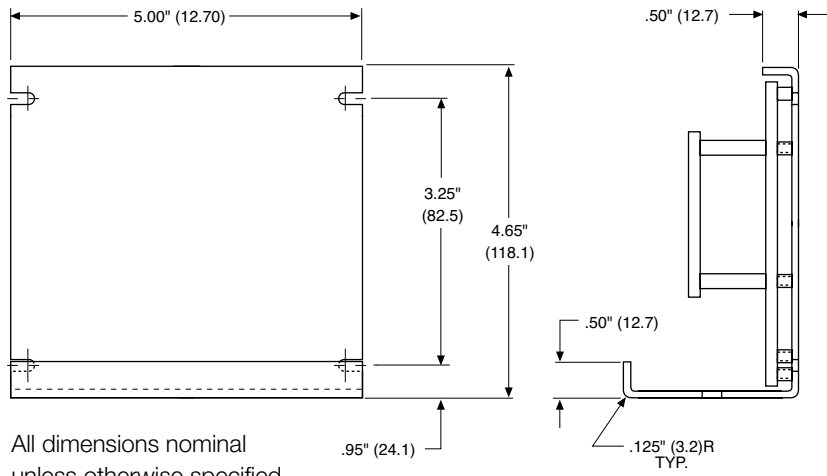

### Connection Diagram

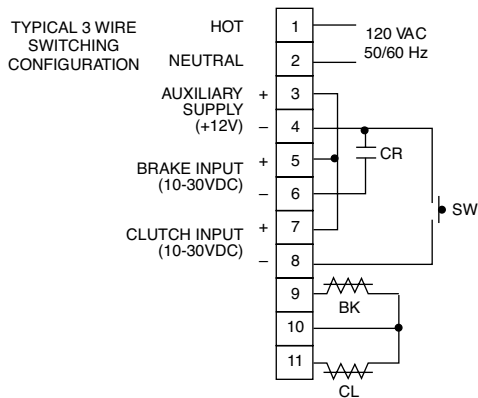

**NOTE:** CR, SW user furnished switch options for use with control.  
 CR normally open relay contact  
 SW normally open push button switch

# CBC-750 Overexcitation Control

## Rapid Acceleration/Deceleration

### CBC-750 Dual channel, current based OEX with switching logic

Warner Electric's CBC-750 Constant Current Overexcitation Clutch/Brake Control is a solid-state electronic control designed to increase the cycle rate capabilities and accuracies of electromagnetic clutches and brakes. The control accomplish this by sending a momentary high voltage overexcitation spike to the clutch and/or brake magnetic coil to build a high density magnetic flux field almost instantaneously. By using overexcitation, the response time is reduced as dramatically as performance is increased. For example, the current build up time of a 5 inch, 6 volt magnet is reduced from 84 milliseconds to 2 milliseconds.

The CBC-750 user selects either 120, 220 or 240 VAC operation at the time of installation, and is available for 6 volt clutches and brakes.

LED indicators on the faceplate of each control tell the user the status of input signals, output activation and any auxiliary inputs. A reset switch resets the output should a short be detected. Remote torque adjust potentiometer inputs are also provided. Appropriate current range for each size clutch or brake is selected by a dip switch. Constant current for each level is assured by the control's design.

- Maintains torque at preset levels regardless of temperature variations
- Automatically controls OEX pulse duration for optimum response without overheating coils
- Automatically prevents clutch and brake "overlap"
- Configurable as an analog follower control through remote top input
- Integral switching logic through auxiliary, inhibit and override inputs



Shown with optional cover, part number 6041-101-004

- High performance OEX control
- Constant current output capability
- Available for 6 volt clutches and brakes
- Outputs short circuit protected.
- AC/DC optically isolated inputs
- Transformer isolation Remote torque potentiometer capability
- Input/Output inhibit functions
- Switch selectable OEX function
- Automatic CH1/CH2 anti-overlap feature
- Heavy duty suppression circuits
- Selectable output current ranges
- Remote status indicators inputs and outputs

### Specifications

CBC-750-6	
Part No.	6041-448-001
Input Power	120/220/240 VAC, $\pm 10\%$ , 50/60 Hz, 350 VA (switch selectable)
Control Inputs	Opto-isolated 10-30 VDC @ 10-35 mA nominal sinking or sourcing, or 24 VAC (50/60Hz) @ 22 mA nominal, or 120 VAC (50/60 Hz) @ 20 mA nominal
Clutch/brake Output	
Steady State Output	
Current controlled	.910 to 4.34 A max.
Current Rise Time	Dependent on clutch/brake size
Current Fall Time	Depending on clutch/brake size
Overexcitation Voltage	75 VDC nom.
Overexcitation Time	Automatic adjustment by control feedback
Anti-overlap Time	Automatic adjustment by control feedback
Power Supply Output	12 VDC, $\pm 0.6$ VDC, 250 mA max.
Auxiliary Indicator	Opto-isolated NPN transistors
Outputs	24 VDC maximum, 20 mA max., reverse polarity protected
Circuit Protection	Internal short circuit protection on each output channel.
Fusing	
AC Input Line	2 Amp, 250 V Slo-Blo
OEX Supply	10 Amp, 32 V Slo-Blo

# CBC-750 Overexcitation Controls

## Rapid Acceleration/Deceleration

Seven optically isolated inputs accept 10-30V A.C./D.C. (TB2) or 120 VAC (TB3), configured through set-up switches

1. Channel 2 Input
2. Channel 2 Input Inhibit (disregards channel 2 input signal)
3. Auxiliary Input
4. Channel 1 Input
5. Channel 1 Input Inhibit (disregards channel 1 input signal)
6. Output Inhibit (deactivates both output channels)
7. Channel 2 Override (applies full voltage to channel 1 output)

### Connection Diagram

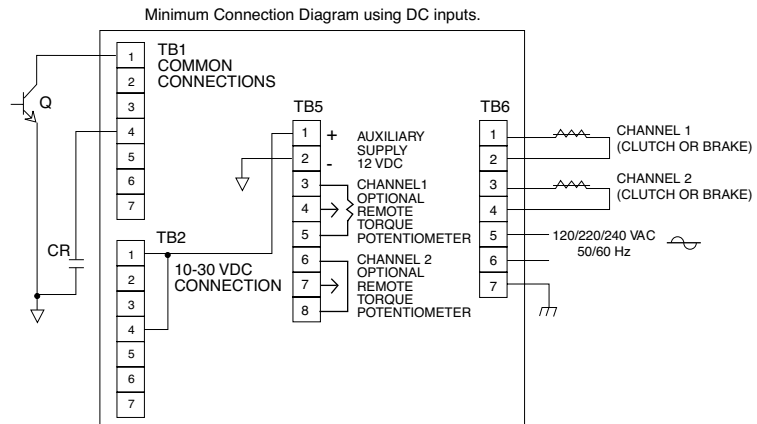

NOTE: Q, CR user furnished switch options for use with control.  
 Q NPN transistor  
 CR normally open relay contact

### Dimensions

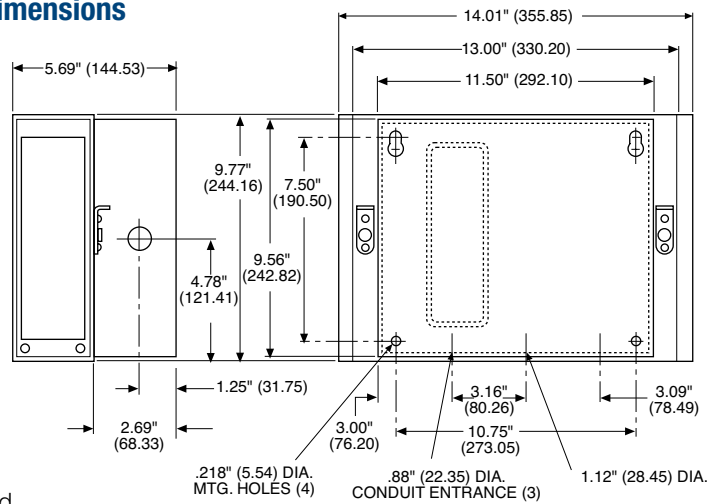

All dimensions nominal unless otherwise specified.

### Setup Switches

SW1: AC Voltage selection switch on terminal board inside control unit

### Max. Current Output

(SW7 & SW8 settings)

Nominal Voltage	1	2	3	4	5
6	0.910	2.35	3.183	3.760	4.340

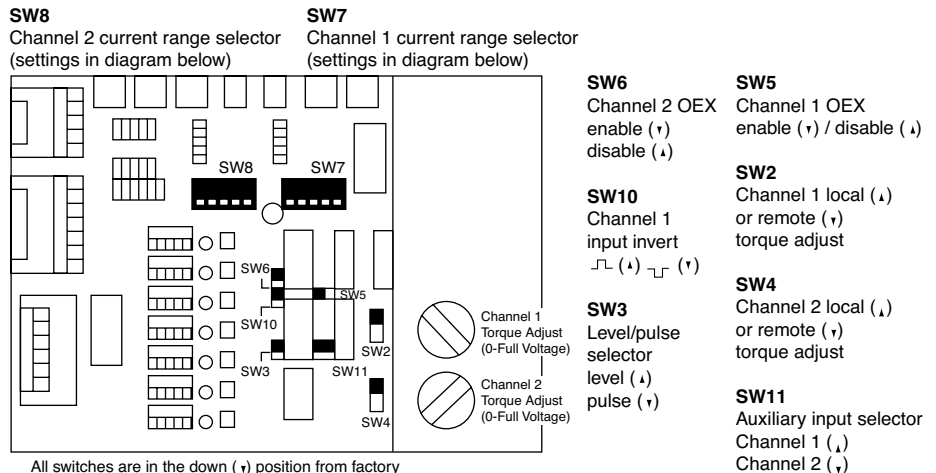

# Appendix

## CBC-500/550 Single vs. Dual Operation

The CBC-500/550 series controls allow operation in either a single or dual mode. The mode of operation is determined via the position of a jumper on the main control board.

The controls are shipped with the jumper in the J1 or single mode position. A variety of output logic can be accomplished via the single/dual jumper position and whether the control is wired to one input switching device (2-wire mode) or two input switching devices (3-wire mode). The following diagrams show how each channel (output) of the control can be either alternately or simultaneously energized.

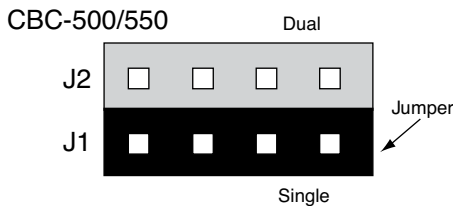

### 2-wire Switching Option

#### Control's switching terminal block

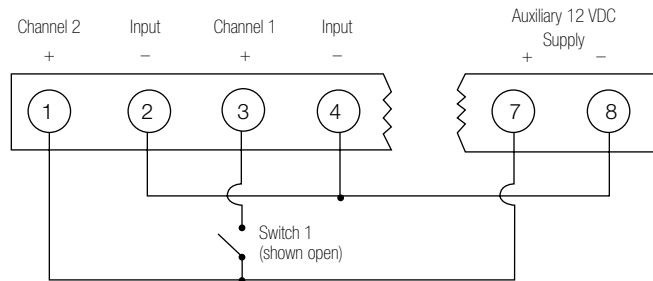

Jumper Mode	Switch 1	Channel 1	Channel 2
J1-Single	Open	Off	Powered
	Closed	Powered	Off
J2-Dual	Open	Powered	Powered
	Closed	Off	Off

### 3-wire Switching Option

#### Control's switching terminal block

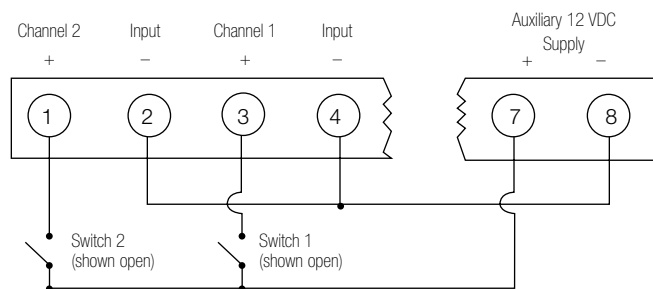

Jumper Mode	Switch 1	Switch 2	Channel 1	Channel 2
J1-Single	Closed	Open	Latched On	Off
	Open	Closed	Off	Latched On
J2-Dual	Closed	Open	Off	Off
	Open	Closed	Latched On	Latched On



## 1. What transformers can be used with controls requiring 24-30 VAC input?

Manufacturer	Part Number	Primary	Secondary
Abbott	6B 12-160	115 VAC	24V @ 6 amps
Quality	6-K-119VBR	115/230 VAC	24V @ 8 amps
Signal	24-6	115 VAC	24V @ 6 amps
Signal	DP24-6	115/230 VAC	24V @ 6 amps
Triad	F-260-U	115 VAC	24V @ 6 amps

## 2. What is the difference between a MCS-801 and a CBC-801-1 or between a MCS-103 and a MCS-103-1?

There is no performance difference between the MCS-103 and MCS-103-1. There is no performance difference between the MCS-801 and CBC-801-1. The CBC-801-1 is roughly 1/4" shorter than the MCS-801. The units wire and work exactly the same.

## 3. Which power supplies can be used with the SF 1525HT and SFC 1525HT coil?

The SF and SFC 1525 High Torque clutch coils require .794 amps of current to provide full rated torque. The following power supplies and controls will provide the needed power.

CBC-100	.8 amps	MCS-103-1	1.25 amps
CBC-150	.8 amps	CBC-500	1 amp
CBC-801	1.25 amps	CBC-550	1 amp

## 4. Can I use a CBC-160 with a variable frequency drive and AC motor?

No. As the voltage to the drive is varied, the output to the electrically released brake would also vary. This would cause the brake to re-engage when it should be released.

## 5. Which power supplies offer a 12 VDC power source that could be used to power auxiliary switch inputs such as inductive or photoelectric sensors?

CBC-500, CBC-550, CBC-700, CBC-750

## 6. We plan to use a PLC in the application. Does that impact our choice of control or power supply?

The CBC-801s and MCS-103-1 are not very PLC friendly. Both require a 10 amp relay for switching which is not very common for PLCs. Alternatives would be CBC-150 or CBC-500/550 respectively which are more 'PLC-Friendly'.

## 7. Which of the controls would allow for the independent operation of two clutches or two brakes?

Four controls allow for completely independent operation of two clutches or brakes. That is, that a clutch and brake can both be on at once, both off at once, or one on and one off. These controls are:

CBC-801-1 and CBC-801-2, MCS-103-1, CBC-300

The CBC-500/550 allows for operation of both channels on at once, both channels off at once or cycling between channel one and two. However, in the both-on/both-off mode, you cannot also do independent single channel operation.

## 8. Our PLC can provide 24 or 90 volts output. Why do we need a separate power supply at all?

There are two reasons to use a Warner Electric control or power supply with clutches and brakes. First, the electric coil within clutches and brakes can create a significant back EMF spike when turned off. This can damage PLC circuits (some PLCs include a diode for protection). All Warner Electric controls and power supplies include a suppression network to protect upstream electrical components from the back EMF spike. Second, this same suppression network will speed the collapse of the magnetic field within a clutch or brake. Without the suppression circuit, a clutch and brake will often overlap each other in performance with resulting poor machine performance.

## 9. Which controls can be used with electrically released brakes?

The CBC-160-1 and CBC-160-2 are designed specifically to use with the conduit box of EM and EUM electrically released brake designs. The CBC-160-1 and CBC-160-2 can also be used with ER and FB brake designs.

The MCS-103-1, CBC-300 and CBC-500/550 can all be used with ER, FB as well as UM-FBC, EM and EUM-FBB and EM and EUM-MBFB designs.

The MCS 805-1 and MCS 805-2 are for use only with the ER 1225 brakes. The ERS series brakes can be used with the CBC-100 or CBC-801 power supplies.

# Ordering Information

---

Model	Part Number	Page
CBC-100-1 .....	6003-448-101 .....	CTL-4
CBC-100-2 .....	6003-448-103 .....	CTL-4
MCS-103-1 .....	6010-448-002 .....	CTL-8
CBC-150-1 .....	6004-448-001 .....	CTL-4
CBC-150-2 .....	6004-448-002 .....	CTL-4
CBC-160-1 .....	6013-448-001 .....	CTL-5
CBC-160-2 .....	6013-448-002 .....	CTL-5
CBC-300 .....	6021-448-009 .....	CTL-10, CTL-11
CBC-300-1 .....	6021-448-002 .....	CTL-11
CBC-500-24 .....	6024-448-002 .....	CTL-12
CBC-500-90 .....	6024-448-003 .....	CTL-12
CBC-550-24 .....	6024-448-005 .....	CTL-14
CBC-550-90 .....	6024-448-006 .....	CTL-14
CBC-1825R .....	1825-448-001 .....	CTL-16
CBC-700-24 .....	6042-448-002 .....	CTL-18
CBC-700-90 .....	6042-448-003 .....	CTL-18
CBC-750-6 .....	6041-448-001 .....	CTL-20
CBC-801-1 .....	6001-448-004 .....	CTL-6
CBC-801-2 .....	6001-448-006 .....	CTL-6
Octal Socket, Foot Mount .....	6001-101-001 .....	CTL-6, CTL-7
Octal Socket, DIN Rail Mount .....	6001-101-002 .....	CTL-6, CTL-7
CBC-802 .....	6002-448-002 .....	CTL-7
Optional Enclosure: CBC-500, CBC-700 .....	6042-101-004 .....	CTL-12, CTL-18
Optional Enclosure: CBC-550 .....	6006-101-007 .....	CTL-14
MCS-805-1 .....	6090-448-006 .....	CTL-9
MCS-805-2 .....	6090-448-007 .....	CTL-9

---

# Part Numbers Ordering Information

**PN**

# Part Numbers Ordering Information

## Electrically Released Brakes- Permanent Magnet

### Permanent Magnet Brakes (Dynamic Cycling)

Description	Model	Part No.	Voltage	Pg. No.
<b>FB</b>	FB-375-1/2	5390-170-021	90	134
		5390-170-024	24	
	FB-375-5/8	5390-170-022	90	134
		5390-170-023	24	
	FB-475	5391-170-009	90	134
5391-170-012		24		
FB-650	5392-170-007	90	134	
	5392-170-010	24		
<b>ER</b>	ER-375	Drawing I-25766	90	138
	ER-475	Drawing I-25755	90	138
	ER-650	Drawing I-25767	90	138
	ER-825 (N.D.)	Drawing I-25577	90	138
	ER-825 (H.D.)	Drawing I-25578	90	138
	ER-1225 (N.D.)	Drawing I-25619	36-75	138
	ER-1225 (H.D.)	Drawing I-25620	35-75	138

### UniModules - UM-FBC

Description	Model	Part No.	Voltage	Pg. No.
<b>Clutch/Brake UniModules</b>	UM-50-1020FBC	5370-273-243	24	144
		5370-273-244	90	
	UM-100-1020FBC	5370-273-248	24	144
		5370-273-249	90	
	UM-180-1020FBC	5370-273-253	24	144
		5370-273-254	90	
	UM-210-1020FBC	5371-273-013	24	144
		5371-273-012	90	
	UM-215-1020FBC	5371-273-099	24	144
		5371-273-079	90	
	UM-50-2030FBC	5370-273-258	24	144
		5370-273-259	90	
	UM-100-2030FBC	5370-273-263	24	144
		5370-273-264	90	
	UM-180-2030FBC	5370-273-268	24	144
		5370-273-269	90	
	UM-210-2030FBC	5371-273-018	24	144
		5371-273-017	90	
	UM-215-2030FBC	5371-273-100	24	144
5371-273-101		90		

### Accessories for UM-FBC, EUM-FBB/MBFB, and EM-FBB/FBC/MBFB

Description	Model	Part No.	Voltage	Pg. No.
<b>Conduit Box</b>	All Sizes	5370-101-042		63
<b>Controls</b>	CBC-160-1	6013-448-001	120 VAC	205
	All Sizes CBC-160-2	6013-448-002	220 VAC	205
<b>Base Mount Kits</b>	UM-50/100	5370-101-004	—	150
	UM-180	5370-101-002		150
2030 (FB only)	UM-210/215	5371-101-019		150
<b>Motor Mount Kits</b> for 20FBB and 1020FBC	EM/UM-50/100	5370-101-078	—	149
	EM/UM-180			
	EUM-50/100/180	5370-101-079		149
	EM/EUM/UM-210 EM/EUM/UM-215	5371-101-012		149

## Shaft Mounted, Flange Mounted and C-face Compatible Units

### Electro Modules

Description	Model	Part No.	Voltage	Pg. No.
<b>Brake Module</b>	EM-50-20FBB	5370-169-278	24	159
		5370-169-279	90	
	EM-100-20FBB	5370-169-283	24	159
		5370-169-284	90	
	EM-180-20FBB	5370-169-288	24	159
		5370-169-289	90	
	EM-210-20FBB	5371-169-032	24	159
		5371-169-029	90	
	EM-215-20FBB	5371-169-100	24	159
		5371-169-054	90	
	EM-50-20FBC	5370-169-233	24	159
		5370-169-234	90	
	EM-100-20FBC	5370-169-238	24	159
		5370-169-239	90	
	EM-180-20FBC	5370-169-243	24	159
		5370-169-244	90	
	EM-210-20FBC	5371-169-031	24	159
5371-169-028		90		
<b>Motor Brake</b>	EM-50-20MBFB	5370-169-248	24	159
		5370-169-249	90	
	EM-100-20MBFB	5370-169-253	24	159
		5370-169-254	90	
	EM-180-20MBFB	5370-169-258	24	159
		5370-169-259	90	
	EM-210-7/8-20MBFB	5371-169-101	24	159
		5371-169-072	90	
	EM-210-20MBFB	5371-169-033	24	159
		5371-169-030	90	

### Enclosed UniModules

Description	Model	Part No.	Voltage	Pg. No.		
<b>Brake Module</b>	EUM-50-20FBB-6	5370-169-260	90	152		
		5370-32	90	152		
		5370-169-261	90	152		
		5370-33	90	152		
		5370-169-262	90	152		
		5370-34	90	152		
		5371-169-078	90	152		
		5371-169-082	90	152		
		5371-169-086	90	152		
		5371-169-090	90	152		
		<b>Motor Brake</b>	EUM-50-20MBFB-6	5370-169-263	90	152
				5370-35	90	152
				5370-169-264	90	152
5370-36	90			152		
5370-169-265	90			152		
5370-37	90			152		
5371-169-064	90			152		
EUM-210-7/8-20MBFB-56	5371-169-068	90	152			
	5371-169-056	90	152			
	5371-169-060	90	152			

## Bushings for Electro Brakes

Description	Model	Part No.
1008	Specify Bore Size 180-0410 to 180-0418	198
1310	Specify Bore Size 180-0421 to 180-0435	198
H-1, H-2	Specify Bore Size 180-0002 to 180-0018	198
1615	Specify Bore Size 180-0131 to 180-0149	198
2517	Specify Bore Size 180-0185 to 180-0217	198



---

# INDEX





# Index

Page	Model Number	Part Number	Service Parts Page
138	ER825	5250-25	297
138	ER825	5250-30	297
138	ER1225	5252-4	297
138	ER1225	5252-9	297
138	ER375	5254-1	296
138	ER475	5255-5	296
138	ER475	5255-6	296
138	ER650	5256-6	296
138	ER650	5256-7	296
	UM-50-1020/CBC-150	5370-9	232
	UM100-1020/CBC150	5370-10	235
	EM100-20MBFB	5370-169-007	NA
	EM100-20FBB	5370-169-020	NA
	EM100-20	5370-169-040	252
	EM100-20	5370-169-041	252
	EM50-20	5370-169-042	252
	EM50-20	5370-169-043	252
	EM50-20	5370-169-045	252
	EM50-20MB	5370-169-047	256
	EM50-20MB	5370-169-048	256
	EM180-20	5370-169-050	252
	EM180-20	5370-169-051	252
	EM180-20MB	5370-169-053	256
	EM180-20MB	5370-169-054	256
	EM50-20FBC	5370-169-056	NA
	EM180-20FBC	5370-169-057	NA
	EM50-20FBB	5370-169-058	NA
	EM180-20FBB	5370-169-059	NA
	EM50-20MBFB	5370-169-060	NA
	EM180-20MBFB	5370-169-061	NA
	EM50-20MB	5370-169-062	256
	EM50-20MBFB	5370-169-063	NA
	EM50-20FBC	5370-169-065	NA
	EM50-20FBB	5370-169-066	NA
	EM180-20FBC	5370-169-067	NA
	EM180-20FBB	5370-169-068	NA
	EM180-20MBFB	5370-169-069	NA
	EM180-20	5370-169-070	252
	EM100-20	5370-169-072	252
	EM180-20MB	5370-169-073	NA
	EM100-20FBB	5370-169-084	NA
	EM100-20MBFB	5370-169-085	NA
	EM100-20FBC	5370-169-108	NA
	EM100-20FBC	5370-169-109	NA
160	EM50-20FBC	5370-169-233	NA
160	EM50-20FBC	5370-169-234	NA
160	EM100-20FBC	5370-169-238	NA
160	EM100-20FBC	5370-169-239	NA
160	EM180-20FBC	5370-169-243	NA
160	EM180-20FBC	5370-169-244	NA
160	EM50-20MBFB	5370-169-248	NA
160	EM50-20MBFB	5370-169-249	NA
160	EM100-20MBFB	5370-169-253	NA
160	EM100-20MBFB	5370-169-254	NA
160	EM180-20MBFB	5370-169-258	NA
160	EM180-20MBFB	5370-169-259	NA
160	EUM50-20FBB-6	5370-169-260	NA
160	EUM100-20FBB-12	5370-169-261	NA
160	EUM180-20FBB-12	5370-169-262	NA
160	EUM50-20MBFB-6	5370-169-263	NA
160	EUM100-20MBFB-12	5370-169-264	NA

Page	Model Number	Part Number	Service Parts Page
160	EUM180-20MBFB-12	5370-169-265	NA
160	EM50-20FBB	5370-169-278	NA
160	EM50-20FBB	5370-169-279	NA
160	EM100-20FBB	5370-169-283	NA
160	EM100-20FBB	5370-169-284	NA
160	EM180-20FBB	5370-169-288	NA
160	EM180-20FBB	5370-169-289	NA
	EUM50-20MBFB-6	5370-169-965	NA
	EUM50-20MBFB-10	5370-169-968	NA
	EUM100-20MBFB-12	5370-169-971	NA
	EUM100-20MBFB-21	5370-169-980	NA
	EUM50-20FBB-6	5370-169-983	NA
	EUM50-20FBB-10	5370-169-986	NA
	EUM100-20FBB-12	5370-169-989	NA
	EUM100-20FBB-21	5370-169-992	NA
	EUM180-20FBB-12	5370-169-995	NA
	EUM180-20FBB-21	5370-169-998	NA
	UM100-3040	5370-271-029	246
	UM100-3040	5370-271-030	246
	UM100-3040	5370-271-031	246
	EUM50-1040	5370-271-050	264
	EUM180-1040	5370-271-051	264
	EUM50-1020	5370-273-057	235
	EUM50-1020	5370-273-058	235
	EUM50-1020	5370-273-059	263
156	EUM50-20FBB-10	5370-32	NA
156	EUM100-20FBB-21	5370-33	NA
156	EUM180-20FBB-21	5370-34	NA
156	EUM50-20MBFB-10	5370-35	NA
156	EUM100-20MBFB-21	5370-36	NA
156	EUM180-20MBFB-21	5370-37	NA
	EM100-40	5370-536-007	261
	EM50-40	5370-536-008	261
	EM180-40	5370-536-009	261
	UM50-1020/CBC150	5370-9	235
160	EM210-20FBC	5371-169-028	NA
160	EM210-20FBB	5371-169-029	NA
160	EM210-20FBC	5371-169-031	NA
160	EM210-20FBB	5371-169-032	NA
160	EM210-20MBFB	5371-169-033	NA
152	EM210-20FBB	5371-169-035	NA
160	EM215-20FBB	5371-169-054	NA
156	EUM210-20MBFB-32	5371-169-056	NA
156	EUM210-20MBFB-56	5371-169-060	NA
156	EUM210-7/8MBFB-32	5371-169-064	NA
156	EUM210-7/8MBFB-56	5371-169-068	NA
156	EUM210-7/8MBFB	5371-169-072	NA
152	EUM210-20FBB-32	5371-169-078	NA
152	EUM210-20FBB-56	5371-169-082	NA
152	EUM215-20FBB-32	5371-169-086	NA
152	EUM215-20FBB-56	5371-169-090	NA
159	EM215-20FBB	5371-169-100	NA
159	EM210-7/8 20MBFB	5371-169-101	NA
159	EM210-20MBFB	5371-269-030	NA
145	UM210-1020FBC	5371-273-012	NA
145	UM210-1020FBC	5371-273-013	NA
145	UM210-2030FBC	5371-273-017	NA
145	UM210-2030FBC	5371-273-018	NA
152	UM215-1020FBC	5371-273-079	NA
152	UM215-2030FBC	5371-273-100	NA
152	UM215-2030FBC	5371-273-101	NA

Page	Model Number	Part Number	Service Parts Page
134	FB375	5390-170-021	294
134	FB375	5390-170-022	294
134	FB375	5390-170-023	294
134	FB375	5390-170-024	294
134	FB475	5391-170-009	294
134	FB475	5391-170-012	294
134	FB650	5392-170-007	294
134	FB650	5392-170-010	294



# Premier Industrial Company Leading Brands

## OTHER PRODUCT SOLUTIONS FROM **ALTRA INDUSTRIAL MOTION**

Our comprehensive product offerings include various types of clutches and brakes, overrunning clutches, engineered bearing assemblies, gearing and gear motors along with linear motion products, belted drives, couplings, limit switches, precision motors, drives & controls, miniature motors and engine braking systems. With thousands of product solutions available, Altra provides true single source convenience while meeting specific customer requirements. Many major OEMs and end users prefer Altra products as their No. 1 choice for performance and reliability.

[WWW.ALTRAMOTION.COM](http://WWW.ALTRAMOTION.COM)



### **Electric Clutches & Brakes**

Inertia Dynamics  
Matrix  
Stromag  
Warner Electric



### **Precision Motors & Automation**

Kollmorgen



### **Heavy Duty Clutches & Brakes**

Industrial Clutch  
Stromag  
Svendborg Brakes  
Twiflex  
Wichita Clutch



### **Miniature Motors**

Portescap



### **Overrunning Clutches**

Formsprag Clutch  
Marland Clutch  
Stieber



### **Linear Systems**

Thomson  
Warner Linear



### **Engineered Couplings & Universal Joints**

Ameridrives  
Bibby Turboflex  
Guardian Couplings  
Huco  
Lamiflex Couplings  
Stromag  
TB Wood's



### **Engine Braking Systems**

Jacobs Vehicle Systems



### **Gear Drives & Gear Motors**

Bauer Gear Motor  
Boston Gear  
Delroyd Worm Gear  
Nuttall Gear



### **Specialty Components**

Kilian  
Stromag  
TB Wood's

## Warner Electric Facilities

### North America

#### USA

31 Industrial Park Road  
New Hartford, CT 06057 - USA  
860-379-1252

*Electromagnetic Clutches  
and Brakes*

449 Gardner Street  
South Beloit, IL 61080 - USA  
815-389-3771

4578 East Park 30 Drive  
Columbia City, IN 46725 - USA  
260-244-6183

*Precision Electric Coils and  
Electromagnetic Clutches and  
Brakes*

#### Customer Service

1-800-825-6544

#### Application Support

1-800-825-9050

### Europe

#### France

7, rue Champfleu, B.P. 20095  
St Barthelemy d'Anjou - France  
+33 (0)2 41 21 24 24

*Electromagnetic Clutches  
and Brakes*

#### Customer Service

+33 (0)2 41 21 24 76

#### Application Support

+33 (0) 2 41 21 24 24

### Asia Pacific

#### Australia

+61 2 9894 0133

#### China

+86 21 5169-9255

#### Hong Kong

+852 2615 9313

#### Singapore

+65 6487 4464

#### Taiwan

+886 2 2577 8156

#### Thailand

+66 2322 5527

## The Brands of Altra Industrial Motion

### Couplings

**Ameridrives**  
[www.ameridrives.com](http://www.ameridrives.com)

**Bibby Turbobox**  
[www.bibbyturbobox.com](http://www.bibbyturbobox.com)

**Guardian Couplings**  
[www.guardiancouplings.com](http://www.guardiancouplings.com)

**Huco**  
[www.huco.com](http://www.huco.com)

**Lamiflex Couplings**  
[www.lamiflexcouplings.com](http://www.lamiflexcouplings.com)

**Stromag**  
[www.stromag.com](http://www.stromag.com)

**TB Wood's**  
[www.tbwoods.com](http://www.tbwoods.com)

### Geared Cam Limit Switches

**Stromag**  
[www.stromag.com](http://www.stromag.com)

### Electric Clutches & Brakes

**Inertia Dynamics**  
[www.idicb.com](http://www.idicb.com)

**Matrix**  
[www.matrix-international.com](http://www.matrix-international.com)

**Stromag**  
[www.stromag.com](http://www.stromag.com)

**Warner Electric**  
[www.warnerelectric.com](http://www.warnerelectric.com)

### Linear Products

**Warner Linear**  
[www.warnerlinear.com](http://www.warnerlinear.com)

### Engineered Bearing Assemblies

**Kilian**  
[www.kilianbearings.com](http://www.kilianbearings.com)

### Heavy Duty Clutches & Brakes

**Industrial Clutch**  
[www.indclutch.com](http://www.indclutch.com)

**Twiflex**  
[www.twiflex.com](http://www.twiflex.com)

**Stromag**  
[www.stromag.com](http://www.stromag.com)

**Svendborg Brakes**  
[www.svendborg-brakes.com](http://www.svendborg-brakes.com)

**Wichita Clutch**  
[www.wichitaclutch.com](http://www.wichitaclutch.com)

### Belted Drives

**TB Wood's**  
[www.tbwoods.com](http://www.tbwoods.com)

### Gearing

**Bauer Gear Motor**  
[www.bauergears.com](http://www.bauergears.com)

**Boston Gear**  
[www.bostongear.com](http://www.bostongear.com)

**Delroyd Worm Gear**  
[www.delroyd.com](http://www.delroyd.com)

**Nuttall Gear**  
[www.nuttallgear.com](http://www.nuttallgear.com)

### Overrunning Clutches

**Formsprag Clutch**  
[www.formsprag.com](http://www.formsprag.com)

**Marland Clutch**  
[www.marland.com](http://www.marland.com)

**Stieber**  
[www.stieberclutch.com](http://www.stieberclutch.com)

Neither the accuracy nor completeness of the information contained in this publication is guaranteed by the company and may be subject to change in its sole discretion. The operating and performance characteristics of these products may vary depending on the application, installation, operating conditions and environmental factors. The company's terms and conditions of sale can be viewed at <http://www.altramotion.com/terms-and-conditions/sales-terms-and-conditions>. These terms and conditions apply to any person who may buy, acquire or use a product referred to herein, including any person who buys from a licensed distributor of these branded products.

©2018 by Warner Electric LLC. All rights reserved. All trademarks in this publication are the sole and exclusive property of Warner Electric LLC or one of its affiliated companies.