

Electro-Packs EP-170, 250, 400, 500, 825, 1000, 1525

Installation Instructions

P-0212
819-0078

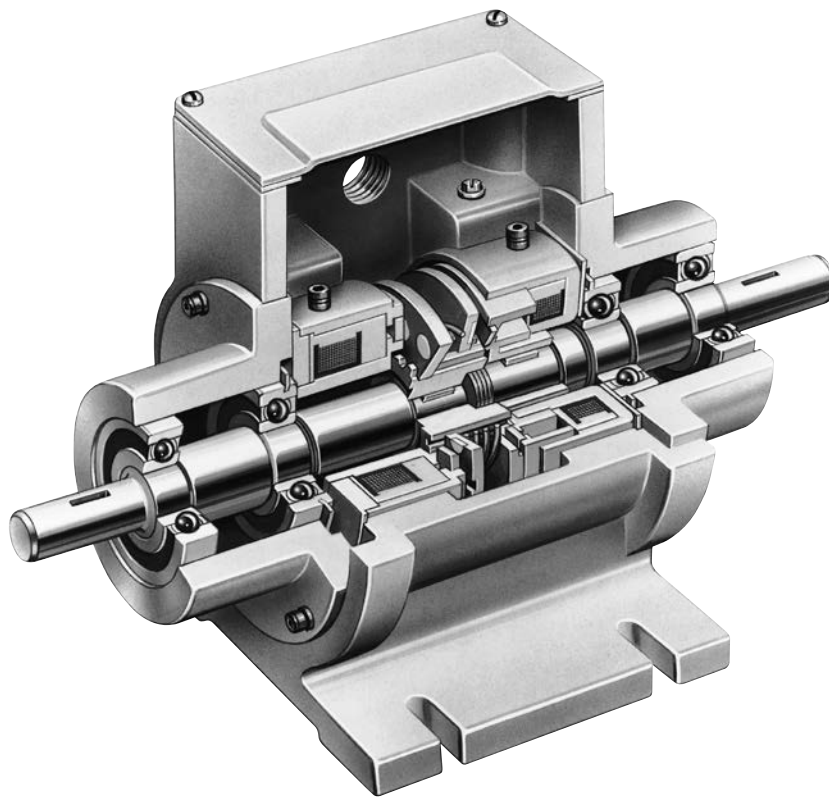

Contents

Features	2
Selection	3
Installation Instructions	4
Replacing Worn Parts	4
Burnishing and Maintenance	6
Electrical Data Coil Ratings	8
Exploded Views and Parts List	
EP-170, 250, 400	9
EP-500	12
EP-825	14
EP-1000	16
EP-1525, 1525 HT	17
Warranty	Back Page

⚠ WARNING Failure to follow these instructions may result in product damage, equipment damage, and serious or fatal injury to personnel.

Base Mounted Clutch/Brake Combinations in a Rugged Housing

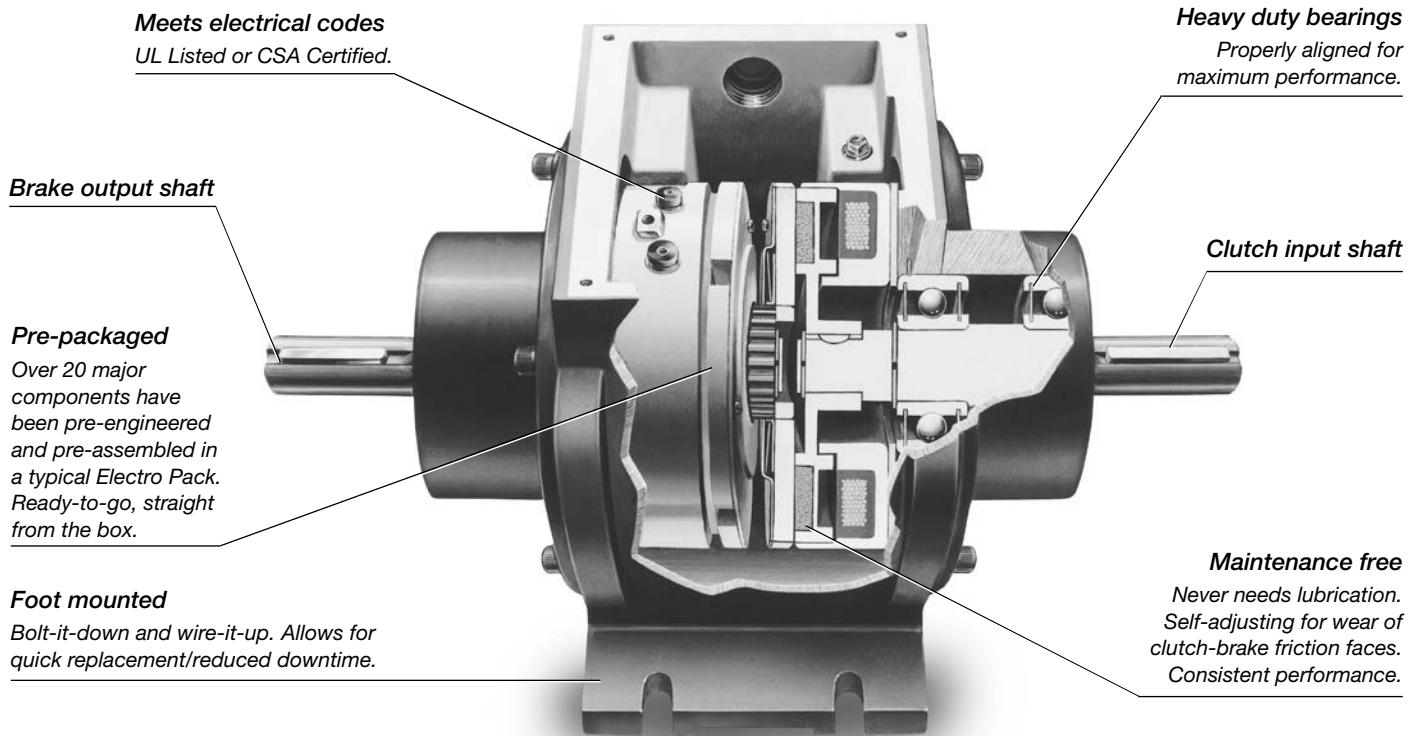

Clutch/Brake Selection Information

Horsepower vs. Shaft Speed

HP ▼	SHAFT SPEED AT CLUTCH (IN RPM)																				
	100	200	300	400	500	600	700	800	900	1000	1100	1200	1500	1800	2000	2400	3000	3600	4000	4500	5000
1/50																					
1/20																					
1/12																					
1/8																					
1/6																					
1/4																					
1/3																					
1/2																					
3/4																					
1																					
1-1/2																					
2																					
3																					
5																					
7-1/2																					
10																					
15																					
20																					
25																					
30																					
40																					

Selection Procedure

Determine the shaft speed at the Electro Pack location. The number listed at the intersection of horsepower and speed is the size Electro Pack you require.

Part Numbers

Model No.	Voltage DC	Part No.
EP-170	6	5633-273-002
	24	5633-273-003
	90	5633-273-005
EP-250	6	5130-273-031
	24	5130-273-032
	90	5130-273-034
EP-400	6	5131-273-009
	24	5131-273-010
	90	5131-273-011
EP-500	6	5230-273-003
	24	5230-273-011
	90	5230-273-002
EP-825	6	5231-273-003
	24	5231-273-004
	90	5231-273-002
EP-1000	6	5232-273-003
	24	5232-273-005
	90	5232-273-002
EP-1525	6	5234-273-003
	90	5234-273-002
EP-1525HT	90	5234-273-012

When ordering, specify size, voltage, and part numbers.

Specifications

Electro-Pack Size	Horsepower @ 1800 RPM	Static Torque	Max. RPM	Voltage DC
EP-170	1/8	15 lb. in.	10,000	6, 24 or 90
EP-250	1/2	70 lb. in.	7,500	6, 24 or 90
EP-400	1	270 lb. in.	4,500	6, 24 or 90
EP-500	2	50/40 lb. ft.	4,000	6 or 90
EP-825	7-1/2	125 lb. ft.	3,600	6 or 90
EP-1000	10	240 lb. ft.	3,000	6 or 90
EP-1525	25	700 lb. ft.	1,800	6 or 90
EP-1525HT	40	1350 lb. ft. clutch 700 lb. ft. brake	1,800	90

Electro-Packs

The Electro-Pack is a pre-assembled clutch/brake package complete with input and output shafts. These units are ready to be installed in all standard power transmission systems—V-belts and pulleys, chain and sprockets, in-line couplings, timing belt drives, and gear trains.

A. Installing the Electro-Packs

1. Provide a mounting surface for the Electro-Pack that is rigid and flat with the following tolerances.

Electro-Pack Sizes	Mounting Surface to be Flat in One Plane Within:
170	.004"
250	.004"
400	.004"
500	.010"
825	.010"
1000	.010"
1525	.010"

2. Connect the Electro-Pack into the drive system. The input shaft is identified on the unit. **Use care when connecting the units!** Serious problems will occur if the power input is connected to the output shaft.

Dimensions for the input and output shafts are shown on the illustration drawings, beginning on page 9.

3. Make the proper electrical connections between the Electro-Pack and a suitable DC power supply. Lead wires or terminals are provided on the clutch and brake for this purpose. A wiring diagram showing the proper connections is furnished with each Warner Electric power supply.

B. Replacing Worn Parts

The normal wearing components of an Electro-Pack are the magnet, two armatures, and rotor. The mating components (magnet and armature or rotor and armature) generally wear at the same rate and should be replaced together.

1. Remove the cover from the Electro-Pack unit. (Figure 1)

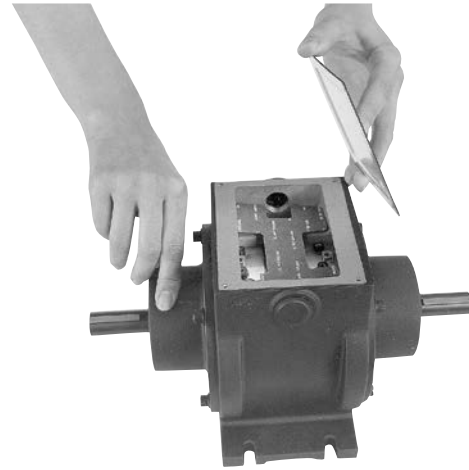

Figure 1

2. Disconnect the wires from the magnet terminals or disconnect the lead wires (EP-170).
3. Remove the capscrews and washers from the output end bell and remove the end bell. (Figure 2)



Figure 2

4. Remove and discard the worn armature(s).
5. Remove the used magnet and discard it. Assemble the new magnet to the end bell. (Figure 3)

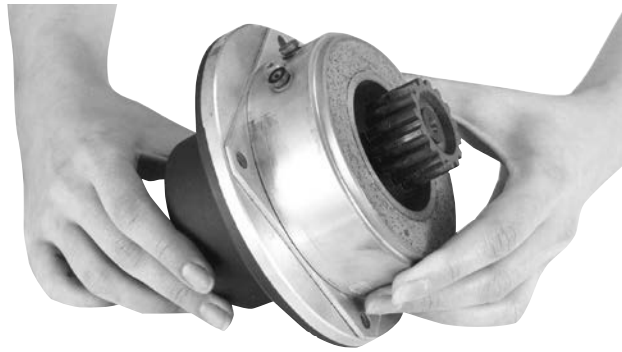

Figure 3

6. Assemble new armature on the armature hub with the segmented side toward the magnet.
7. Assemble the second armature in the opposite direction of the first. (Figure 4)

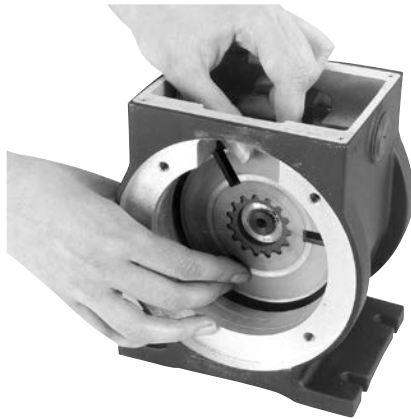

Figure 4

8. Proceed as follows for EP-170 through 500 (go to instruction 9 for EP-825 through 1525):
 - a. Remove the retainer ring holding the rotor on the output shaft.
 - b. Remove the rotor and replace it with a new one. Replace the retainer ring. (Figure 5)

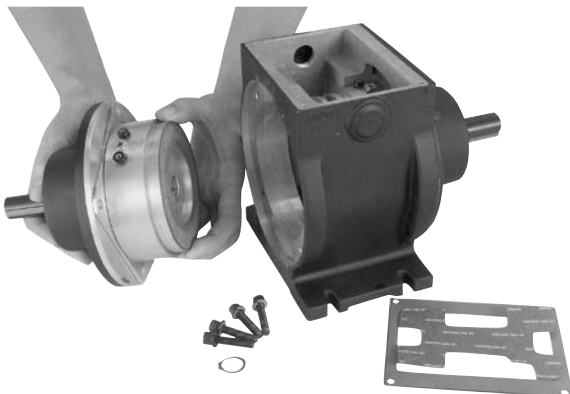

Figure 5

9. Proceed as follows for EP-825-1525:
 - a. Slide the rotor and rotor hub assembly with taperlock bushing over the shaft.
 - b. Remove the rotor hub from the worn rotor by unscrewing the capscrews and install the hub and bushing on the new rotor.
 - c. Remove any burrs, chips, dirt, or other foreign material from the field, rotor assembly, and shaft.
 - d. Slide the new rotor assembly onto its shaft the same way it was removed. Note the line scribed on the O.D. of the field to help maintain the correct axial clearance between the rotor and field. Tighten the bushing to secure the assembly in place on the shaft.
10. Reassemble the end bell in the Electro-Pack unit. Reassemble the capscrews and washers to the unit.
11. Set the autogaps by pressing each armature into contact with its mating component (either the magnet or rotor) and then releasing it. (Figure 6)

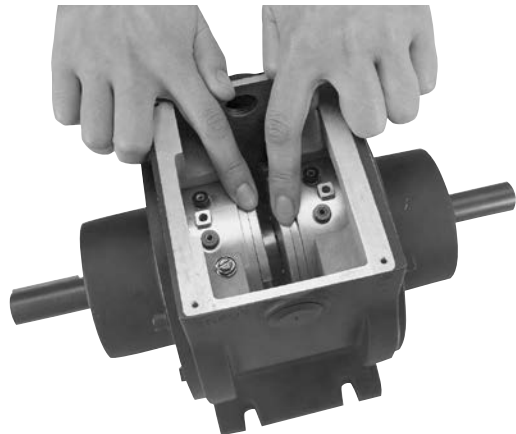

Figure 6

12. Reconnect the electrical wires to the magnet.
13. Reassemble the cover to the unit.

Burnishing and Maintenance

Burnishing

Intimate metal to metal contact is essential between the armature and the metal rings (poles) of the magnet or rotor. Warner Electric clutches and brakes leave the factory with the friction material slightly undercut to assure good initial contact.

Normally, the desired wearing-in process occurs naturally as the surfaces slip upon engagement. The time for wear-in, which is necessary to obtain the ultimate torque of the unit, will vary depending on speed, load, or cycle duty.

If maximum torque is required immediately after installation, the unit should be burnished by slipping the friction surfaces together at reduced voltage. It is recommended that the burnishings be done right on the application, if at all possible.

Burnishing at high speed will result in a smoother wear-in pattern and reduce the time for burnishing. The voltage should be set at approximately 30% or 50% of the rated value.

The unit should be cycled on and off to allow sufficient time between slip cycles to prevent overheating.

When a Warner Electric brake or clutch is properly assembled and installed, no further servicing, lubrication, or maintenance should be required throughout the life of the unit.

Maintenance

Wear Pattern: Wear grooves appear on the armature and magnet surfaces. This is a normal wear condition, and does not impair functioning of the unit. Normally, the magnet and armature, as a mating pair, will wear at the same rate. It is the usual recommendation that both components be replaced at the same time.

Remachining the face of a worn armature is not recommended. If a replacement armature is to be used with a used magnet, it is necessary to remachine the worn magnet face. In refacing a magnet: (1) machine only enough material to clean up the complete face of the magnet; (2) hold the face within .005" of parallel with the mounting plate; and (3) undercut the molded facing material .001" - .003" below the metal poles.

Heat: Excessive heat and high operating temperatures are causes of rapid wear. Units, therefore, should be ventilated as efficiently as possible, especially if the application requires fast, repetitive cycle operation.

Foreign Materials: If units are used on machinery where fine, abrasive dust, chips or grit are dispelled into the atmosphere, shielding of the brake may be necessary if maximum life is to be obtained.

Where units are used near gear boxes or transmissions requiring frequent lubrication, means should be provided to protect the friction surfaces from oil and grease to prevent serious loss of torque.

Oil and grease accidently reaching the friction surfaces may be removed by wiping with a rag dampened with a suitable cleaner, which leaves no residue. In performing this operation, do not drench the friction material.

If the friction materials have been saturated with oil or grease, no amount of cleaning will be completely effective. Once such a unit has been placed back in service, heat will cause the oil to boil to the surface, resulting in further torque loss.

Torque Loss: If a brake or clutch slips or loses torque completely, the initial check should be the input voltage to the magnet as follows:

90-Volt Series: Connect a DC voltmeter with a range of 0-100 or more directly across the magnet terminals. With the power on and the potentiometer turned up, a normal reading is 90 volts, although 85 to 95 is satisfactory. The reading should drop as the potentiometer control is adjusted counterclockwise.

24-Volt Series: Use a DC voltmeter with a range of 0-30 volts or more. A normal reading is approximately 22-26 volts.

6-Volt Series: Use a DC voltmeter of approximately 0-15 volt range. A normal reading is from 5.5 to 6.5 volts.

The above checks normally are sufficient. Further checks may be necessary, such as voltage, amperage and resistance. Refer to chart on following page for electrical readings on the clutch / brake you are measuring. Observe all safety procedures and test equipment manufacturers operating procedures. The voltage and amperage measurements are made with the power on and the control at full output. Resistance

measurements are made with power off and clutch / brake disconnected from control, measuring only the clutch coil or the brake magnet. Resistance measurements should be + / - 10% of values on chart.

If the above checks indicate that the proper voltage and current is being supplied to the clutch and brake, mechanical parts should be checked to assure that they are in good operating condition and properly installed.

Electrical Data Coil Ratings

EP-170	Clutch			Brake		
Voltage – DC	6	24	90	6	24	90
Resistance @ 20° C – Ohms	6.96	111.2	1506	6.96	111.2	1506
Current – Amperes	.861	.215	.060	.861	.215	.060
Watts	5.16	5.16	5.37	5.16	5.16	5.37
Coil Build up – milliseconds	17	17	16	17	17	16
Coil Decay – milliseconds	8	7	6	8	7	6

EP-250	Clutch			Brake		
Voltage – DC	6	24	90	6	24	90
Resistance @ 20° C – Ohms	5	76.4	1079	5	76.4	1079
Current – Amperes	1.2	.314	.084	1.2	.314	.084
Watts	7.2	7.5	7.51	7.2	7.5	7.51
Coil Build up – milliseconds	48	48	44	48	48	44
Coil Decay – milliseconds	15	15	13	15	15	13

EP-400	Clutch			Brake		
Voltage – DC	6	24	90	6	24	90
Resistance @ 20° C – Ohms	4.88	73	1087	4.88	73	1087
Current – Amperes	1.230	.332	.083	1.230	.332	.083
Watts	7.69	8.04	7.45	7.69	8.04	7.45
Coil Build up – milliseconds	154	154	154	154	154	154
Coil Decay – milliseconds	62	60	55	62	60	55

EP-500	Clutch			Brake		
Voltage – DC	6	24	90	6	24	90
Resistance @ 20° C – Ohms	1.076	14.9	206.1	1.36	23.8	251.1
Current – Amperes	5.580	1.610	.440	4.400	1.010	.360
Watts	34	39	39	26	24	32
Coil Build up – milliseconds	82	85	90	84	87	93
Coil Decay – milliseconds	40	40	40	38	35	30

EP-825	Clutch			Brake		
Voltage – DC	6	24	90	6	24	90
Resistance @ 20° C – Ohms	1.23	20.9	267	1.27	20.4	223.3
Current – Amperes	4.900	1.150	.340	4.740	1.180	.400
Watts	29	28	30	28	28	36
Coil Build up – milliseconds	222	200	245	170	170	170
Coil Decay – milliseconds	105	120	100	70	75	80

EP-1525	Clutch		Brake	
Voltage – DC	6	90	6	90
Resistance @ 20°C. – Ohms	1.11	239.1	1.45	258.4
Current – Amperes	5.410	.380	4.130	.350
Watts	32	34	25	31
Coil Build up – milliseconds	505	575	470	512
Coil Decay – milliseconds	230	215	200	140

EP-1525HT	Clutch	Brake
	Voltage – DC	90
Resistance @ 20°C. – Ohms	113.4	238
Current – Amperes	.794	.378
Watts	72	34
Coil Build up – milliseconds	560	512
Coil Decay – milliseconds	160	140

Build-up time equals current to approximately 90% of steady state value and flux to 90%. Decay time equals current to approximately 10% of steady state value and flux to 10%. Approximately because currently leads or lags flux by small amount.

EP-170, EP-250, EP-400

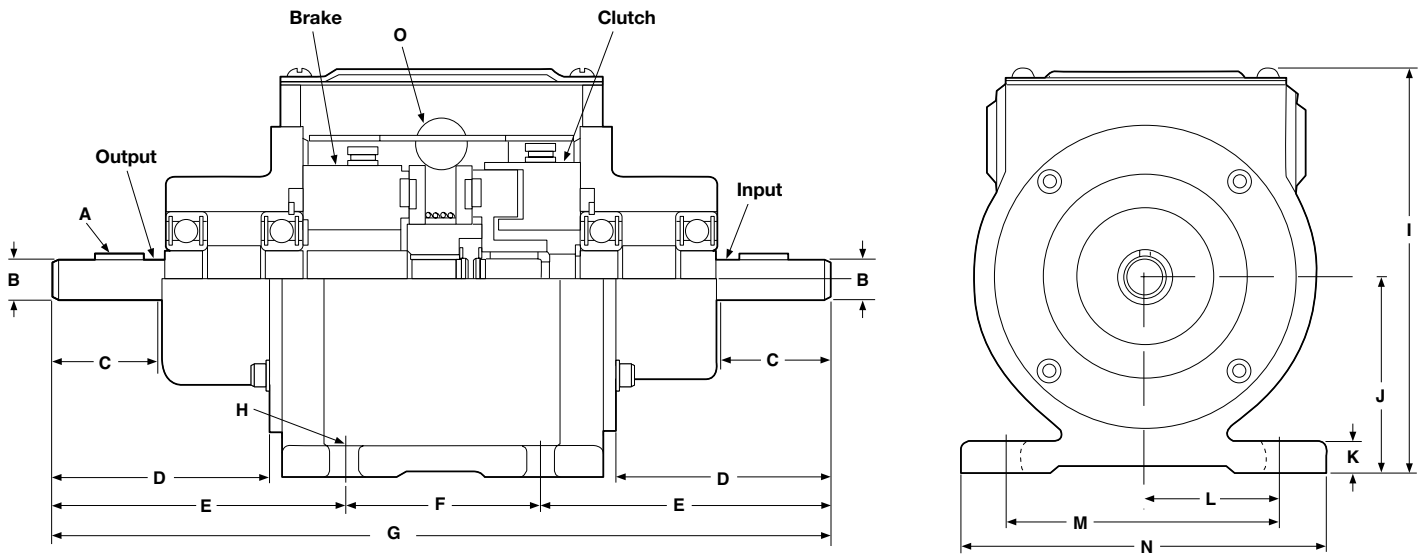

All dimensions are nominal, unless otherwise noted.

Size	A	B	C Min.	D	E	F	G Max.	H	I	J	K	L	M	N	O
170	3/32 x 3/64	.3745 .3735 Dia.	.750	1.406	2.203	1.500	6.000	.250 Wide (4 slots)	3.437	1.662 1.652	.312	1.110	2.220	3.250	1/2 - 14 NPT conduit x 2
250	1/8 x 1/16	.4995 .4985 Dia.	1.250	2.468	3.312	2.250	8.968	.312 Wide (4 slots)	5.281	2.318 2.308	.375	1.625	3.250	4.250	1/2 - 14 NPT conduit x 2
400	3/16 x 3/16 x 1-1/2	.7495 .7485 Dia.	1.875	3.515	4.593	2.500	11.781	.312 Wide (4 slots)	6.937	3.474 3.464	.500	2.578	5.156	6.000	1/2 - 14 NPT conduit x 2

Specifications

Model Size	Voltage DC	Static Torque lb. in.	Inertia-WR ² (lb-in ²)		Max. RPM	Weight lbs.
			Output	Input		
EP-170	6	15	.031	.036	10,000	2.5
	24	15	.031	.036	10,000	2.5
	90	15	.031	.036	10,000	2.5
EP-250	6	70	.331	.293	7,500	7.1
	24	70	.331	.293	7,500	7.1
	90	70	.331	.293	7,500	7.1
EP-400	6	270	2.566	2.222	4,500	19.7
	24	270	2.566	2.222	4,500	19.7
	90	270	2.566	2.222	4,500	19.7

EP-170, EP-250, EP-400

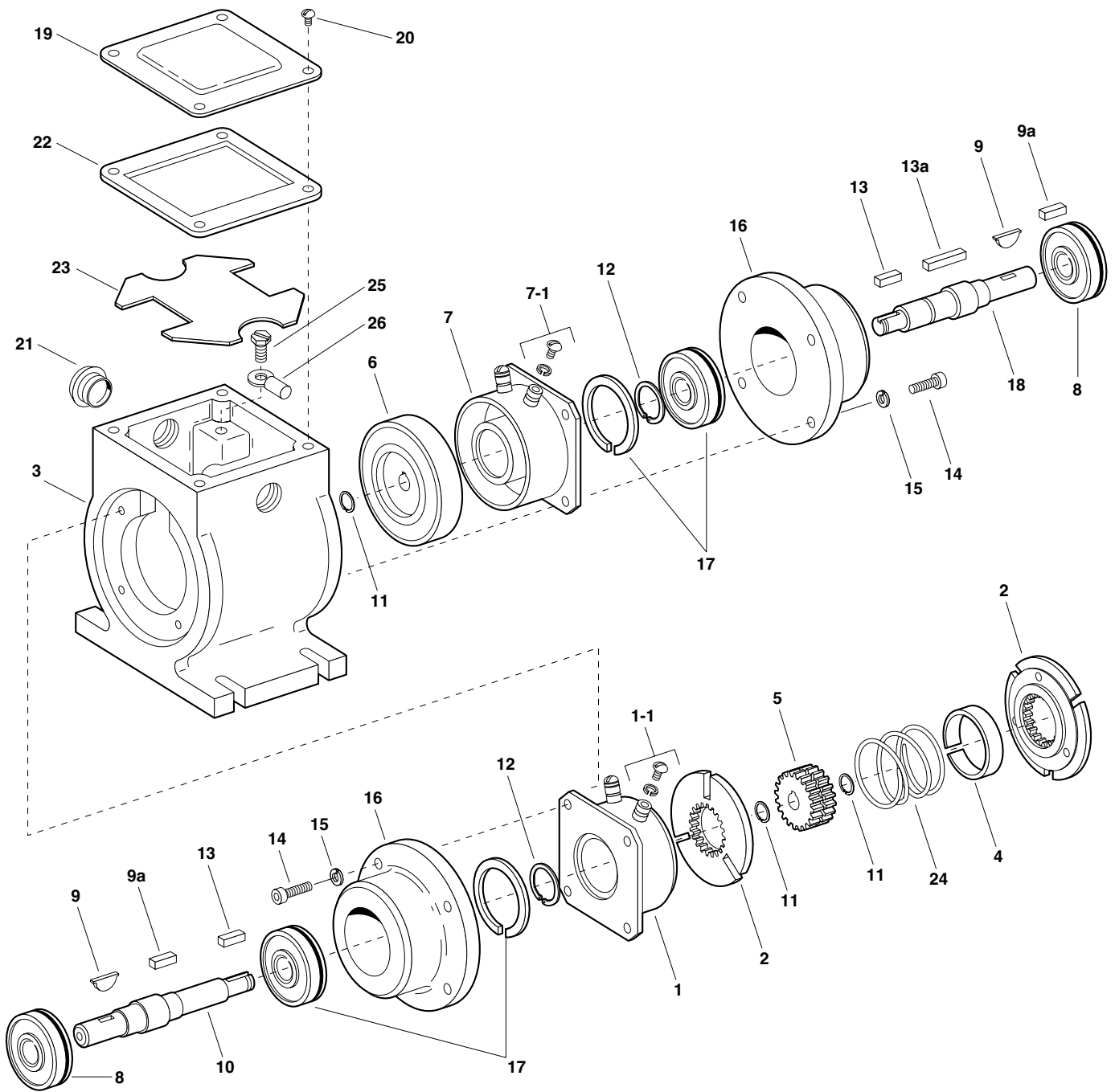

EP-170, EP-250, EP-400

Component Parts

Item	Description	EP-170		EP-250		EP-400	
		Part No.	Qty.	Part No.	Qty.	Part No.	Qty.
1	Magnet Assembly 6 volt 24 volt 90 volt	5375-631-003 5375-631-005 5375-631-007	1	5319-631-002 5319-631-003 5319-631-005	1	5115-631-002 5115-631-003 5115-631-004	1
1-1	Terminal Accessory	†		5103-101-002	1	5103-101-002	1
2	Armature Assembly with Autogap	110-0111	2	5130-111-008	2	5131-111-001	2
3	Housing	535-0079	1	535-0082	1	535-0083	1
4	Armature Spacer	807-1021	1				
5	Splined Armature Hub	540-1250	1	540-1635	1	540-2034	1
6	Rotor Assembly	5603-751-029	1	5103-751-010	1	5104-751-034	1
7	Field Assembly 6 volt 24 volt 90 volt	5603-451-047 5603-451-049 5603-451-051	1	5103-451-002 5103-451-004 5103-451-007	1	5104-451-032 5104-451-033 5104-451-034	1
7-1	Terminal Accessory	†		5103-101-002	1	5103-101-002	1
8	Ball Bearing	166-0112	2	166-0114	2	166-0116	2
9	Key	590-0095	2	590-0014	2		
9a	Key					590-0016	2
10	Shaft, Brake	798-0136	1	798-0133	1	798-0131	1
11	Retainer Ring	748-0346	2	748-0347	2	748-0348	2
12	Retainer Ring	748-0042	2	748-0024	2	748-0022	2
13	Key	590-0089	2	590-0088	2	590-0087	1
13a	Key					590-0106	1
14	Capscrew	797-1219	8	797-1219	8	797-1220	8
15	Lockwasher	950-0351	8	950-0351	8	950-0355	8
16	Bearing Housing	535-0080	2	535-0081	2	535-0084	2
17	Ball Bearing, with Retainer	166-0111	2	166-0113	2	166-0115	2
18	Shaft, Clutch	798-0135	1	798-0134	1	798-0132	1
19	Cover Plate	686-1017	1	686-1018	1	686-1019	1
20	Screw	797-0015	4	797-0015	4	797-0015	4
21	Dust Plug	680-0037	2	680-0037	2	680-0037	2
22	Gasket	495-0003	1	495-0004	1	495-0005	1
23	Insulator	572-0573	1	572-0572	1	572-0574	1
24	Vertical Mfg. Spring Kit Optional	5603-101-001	1	5103-101-006	1	5104-101-005	1
25	Ground Screw		1	797-1245	1	797-1245	1
26	Terminal		1	900-0116	1	900-0016	1

†Lead wires used on EP-170.

These units meet the standards of UL508 and are listed under guide card #NMTR, file #59164. These units are CSA certified under file #LR11543.

EP-500

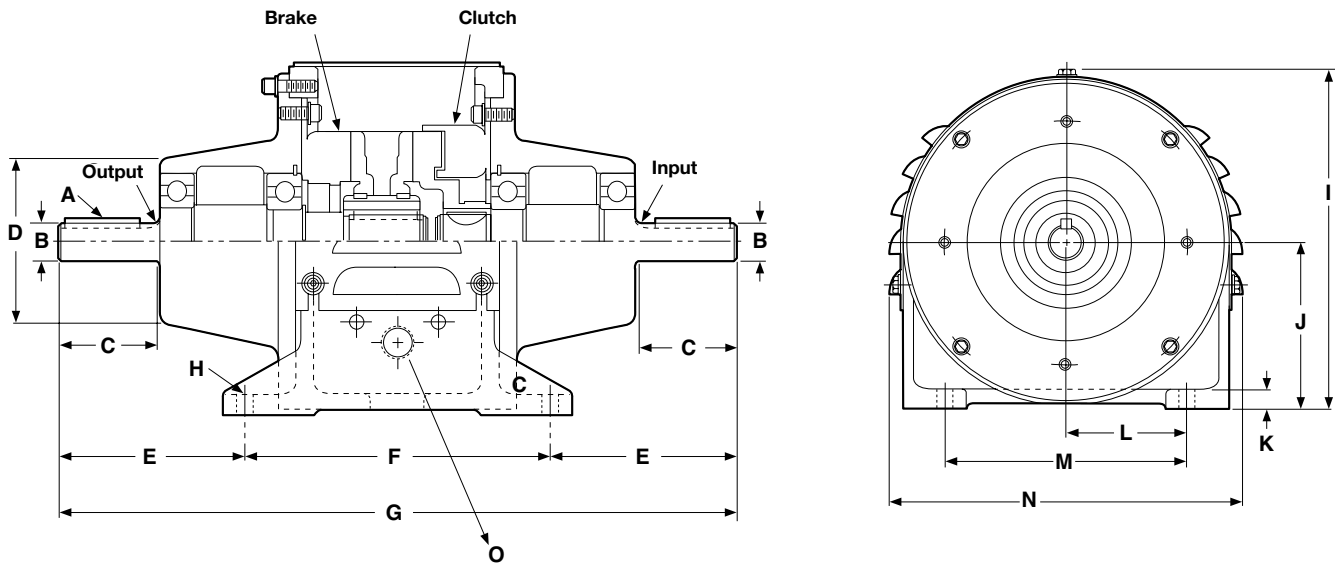

All dimensions are nominal, unless otherwise noted.

Size	A	B Dia.	C Min.	D Max. Dia.	E	F	G Max.	H Dia. (4 holes)	I	J	K	L	M	N Max.	O
500	3/16 x 3/16 x 1-3/4	.8750 .8745	2.218	3.796	4.234	7.000	15.515	.406 (4 holes)	8.218	4.004 3.992	.500	2.937	5.875	8.734	1/2 - 14 NPT conduit x 2

Specifications

Model Size	Voltage DC	Unit	Static Torque	Inertia-WR ² lb.ft. ²	Max. RPM	Weight lbs.
EP-500	6, 24 and 90	Clutch Brake	50 40	.039 .063	4000	56

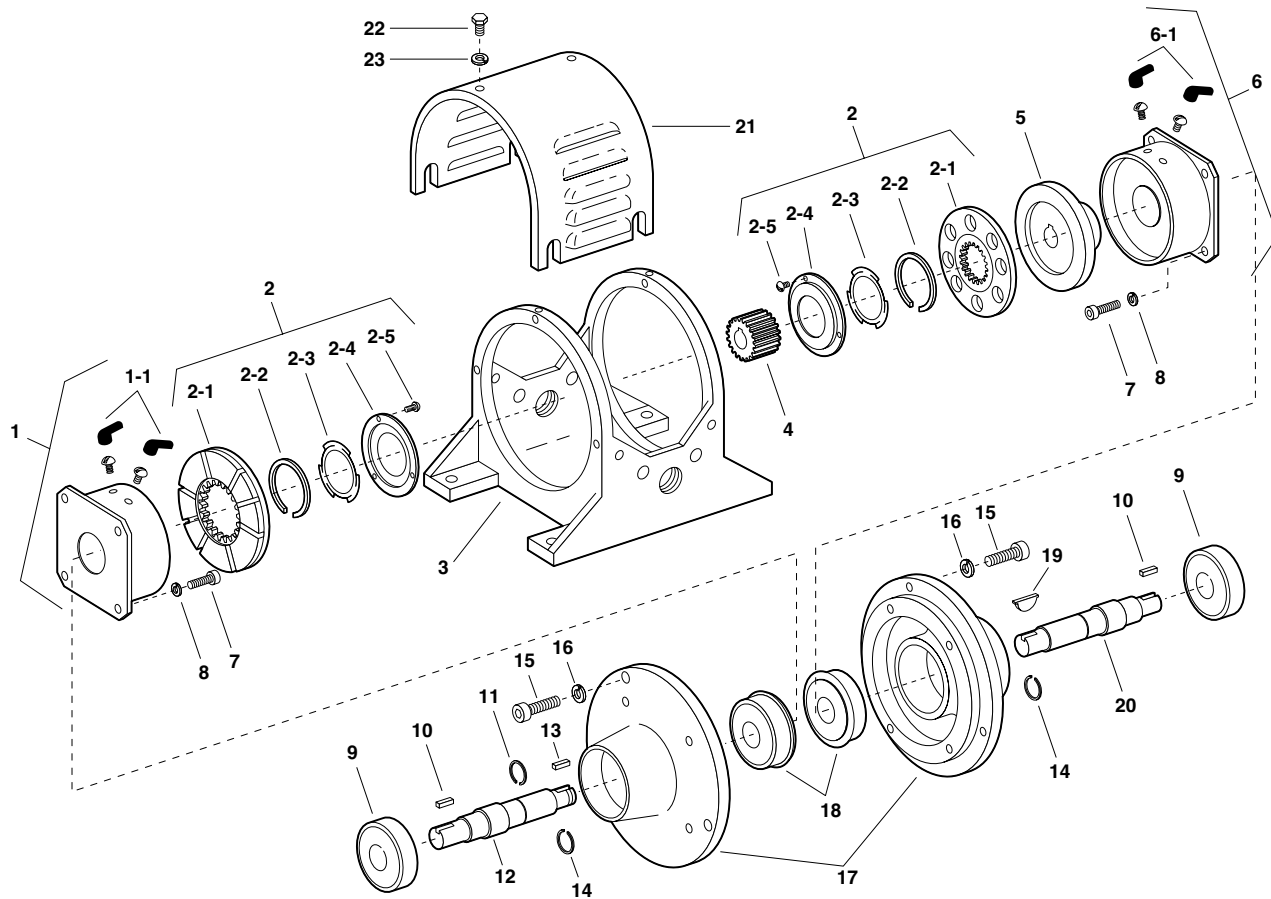

Component Parts

Item	Description	Part No.	Qty.	Item	Description	Part No.	Qty.
1	Magnet Assembly		1	10	Key	590-0020	2
	6 volt	5300-631-009		11	Retainer Ring	748-0361	1
	24 volt	5300-631-010		12	Shaft, Brake	798-0022	1
	90 volt	5300-631-011		13	Key	590-0022	1
1-1	Terminal Accessory	5311-101-001	1	14	Retainer Ring	748-0335	2
2	Armature Assembly	5230-111-002	2	15	Cap screw	797-0418	8
2-1	Armature	5230-111-001	2	16	Lockwasher	950-0107	8
2-2	Retainer Ring	748-0355	2	17	Endbell Housing	535-0010	2
2-3	Spring	808-0412	2	18	Ball Bearing	166-0127	2
2-4	Retainer Plate	748-0364	2	19	Key	590-0021	1
2-5	Screw	797-1430	12	20	Shaft, Clutch	798-0023	1
3	Mounting Frame	174-0028	1	21	Cover Drip Proof	287-0068	1
4	Splined Hub	540-2035	1	22	Cap screw	797-1288	6
5	Rotor	5230-751-001	1	23	Lockwasher	950-0102	6
6	Field		1	*NS	Clamp Wire Speed Nut	263-0016	2
	6 volt	5230-451-003		*NS	Wire Assembly (Red)	5232-954-003	2
	24 volt	5230-451-005		*NS	Wire Assembly (Black)	5232-954-004	2
	90 volt	5230-451-002		*NS	Screws	797-1007	2
6-1	Terminal Accessory	5311-101-001	1	*NS	Insulator Bushing	572-0522	1
7	Cap screw	797-0416	8				
8	Lockwasher	950-0107	8				
9	Ball Bearing	166-0125	2				

*NS - Not Shown
 These units meet the standards of UL508 and are listed under guide card #NMTR, file #59164. These units are CSA certified under file #LR11543.

EP-825

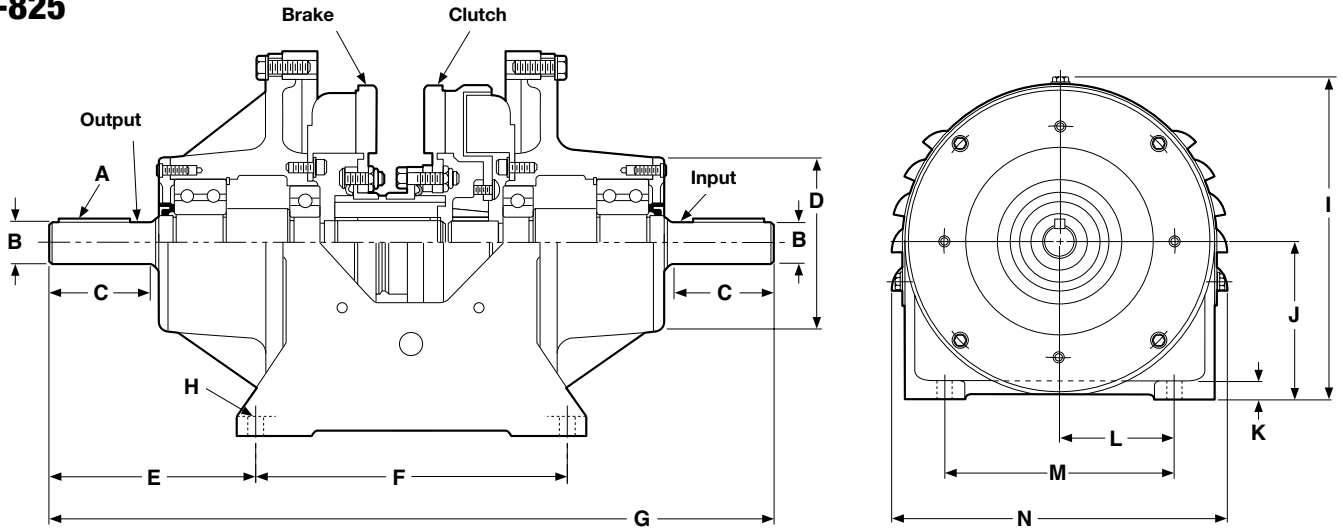

All dimensions are nominal, unless otherwise noted.

Size	A	B Dia.	C Min.	D Max. Dia.	E	F	G Max.	H	I	J	K	L	M	N Max.
825	1/4 x	1.1250	2.875	5.000	5.734	8.500	20.031	.406 Dia.	10.812	5.254	.562	4.250	8.500	11.609
	1/4 x 2	1.1245						(4 holes)		5.252				

Specifications EP-825

Model Size	Voltage DC	Unit	Static Torque	Inertia-WR ² (lb-ft ²)		Max. RPM	Weight lbs.
				Output Side	Input Side		
EP-825	6, 24 & 90	Clutch & Brake	125	.897	.510	3600	123
			125				

Specifications EP-1000

Model Size	Voltage DC	Static Torque	Inertia-WR ² (lb-ft ²)		Max. RPM	Weight lbs.
			Output Side	Input Side		
EP-1000	6	240 lb.ft.	1.45	1.01	3000	288
	24	240 lb.ft.	1.45	1.01	3000	288
	90	240 lb.ft.	1.45	1.01	3000	288

All dimensions are nominal, unless otherwise noted.

Size	A	B Dia.	C Min.	D Dia.	E	F	G Max.	H	I	J	K	L	M	N Max.
1000	1/2 x	1.875	4.750	5.687	8.250	12.250	28.750	.656 Dia.	12.500	6.255	.718	5.000	10.000	12.875
	1/2 x	1.874						(4 holes)		6.241				
	3-3/4													

EP-1000

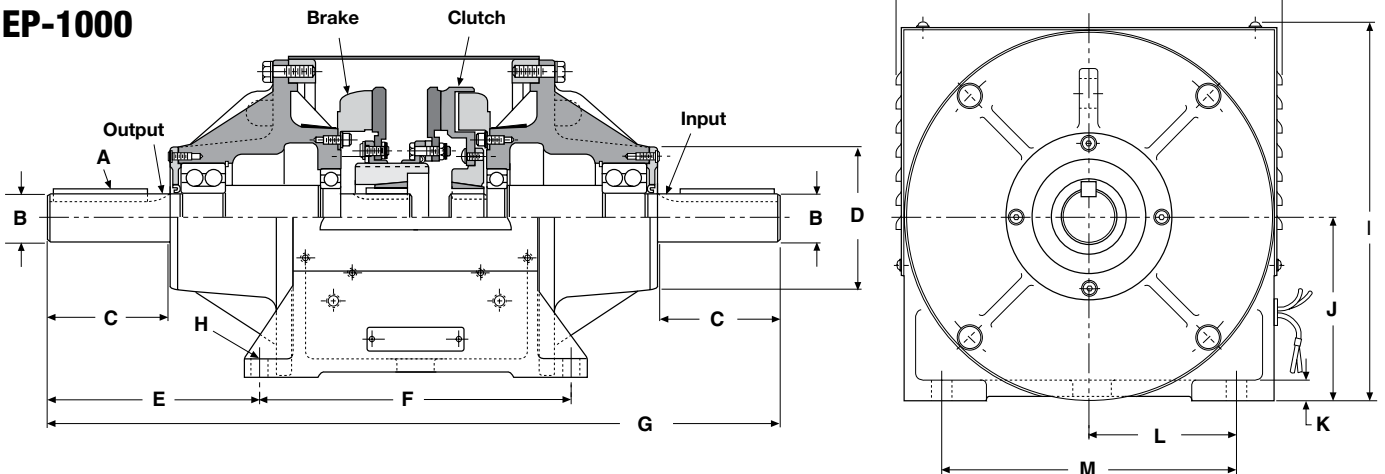

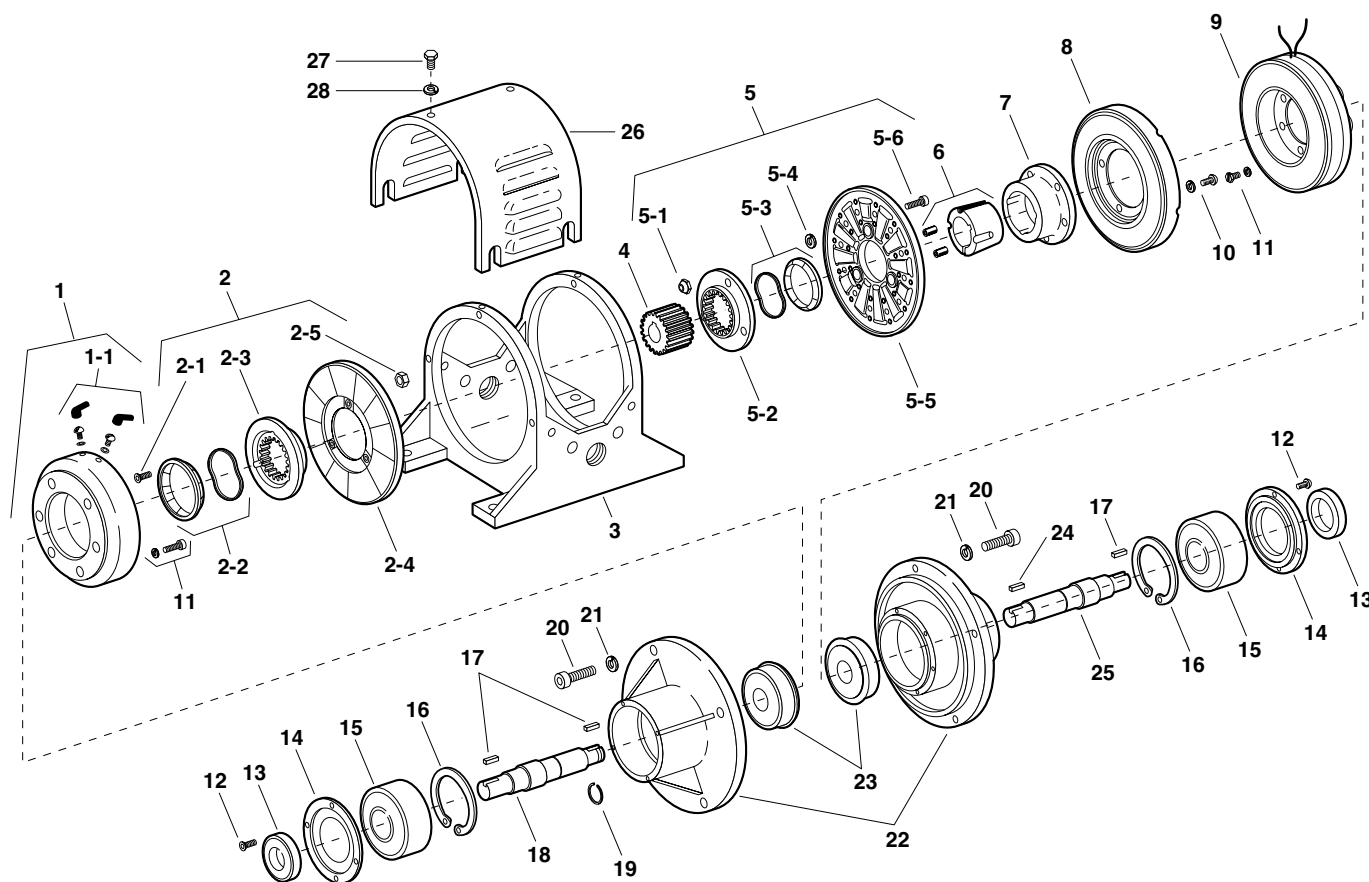

Component Parts

Item	Description	Part No.	Qty.
1	Magnet Assembly 6 volt 24 volt 90 volt	5311-631-002 5311-631-003 5311-631-004	1
1-1	Terminal Accessories	5311-101-001	1
2	Armature Assembly & Splined Adapter	5321-111-001	1
2-1	Screw	797-0272	3
2-2	Autogap Accessory	5321-101-006	1
2-3	Splined Adapter	104-0008	1
2-4	Armature	5321-111-022	1
2-5	Locknut	661-0004	3
3	Frame	174-0019	1
4	Splined Hub	540-0320	1
5	Armature & Splined Adapter	5201-111-001	1
5-1	Locknut	661-0004	3
5-2	Splined Adapter	104-0008	1
5-3	Autogap Accessory	5321-101-006	1
5-4	Spacer	748-0333	3
5-5	Armature	5321-111-022	1
5-6	Screw	797-0341	3
6	Bushing, 1-1/4" Bore	180-0113	1
7	Rotor Hub	540-0013	1
8	Rotor	5201-751-003	1
9	Field 6 volt 24 volt 90 volt	5201-451-006 5201-451-008 5201-451-010	1

Item	Description	Part No.	Qty.
10	Mounting Accessory	5201-101-007	1
11	Mounting Accessory	5321-101-001	2
12	Screw	797-1008	8
13	Oil Seal	795-0023	2
14	Retainer Plate	686-0031	2
15	Ball Bearing	166-0126	2
16	Retainer Ring	748-0336	2
17	Key	590-0019	3
18	Shaft, Brake	798-0019	1
19	Retainer Ring	748-0335	1
20	Capscrew	797-0351	8
21	Lockwasher	950-0354	8
22	Endbell Housing	535-0005	2
23	Ball Bearing	166-0125	2
24	Key	590-0018	1
25	Shaft, Clutch	798-0020	1
26	Cover, Drip Proof	287-0069	1
27	Capscrew	797-1288	6
28	Lockwasher	950-0102	6
*NS	Clamp Wire Speed Nut	263-0016	2
*NS	Wire Assembly (Red)	5232-954-003	2
*NS	Wire Assembly (Black)	5232-954-004	2
*NS	Screws	797-1007	2
*NS	Insulator Bushing	572-0522	1

*NS - Not Shown

These units meet the standards of UL508 and are listed under guide card #NMTR, file #59164. These units are CSA certified under file #LR11543.

EP-1000

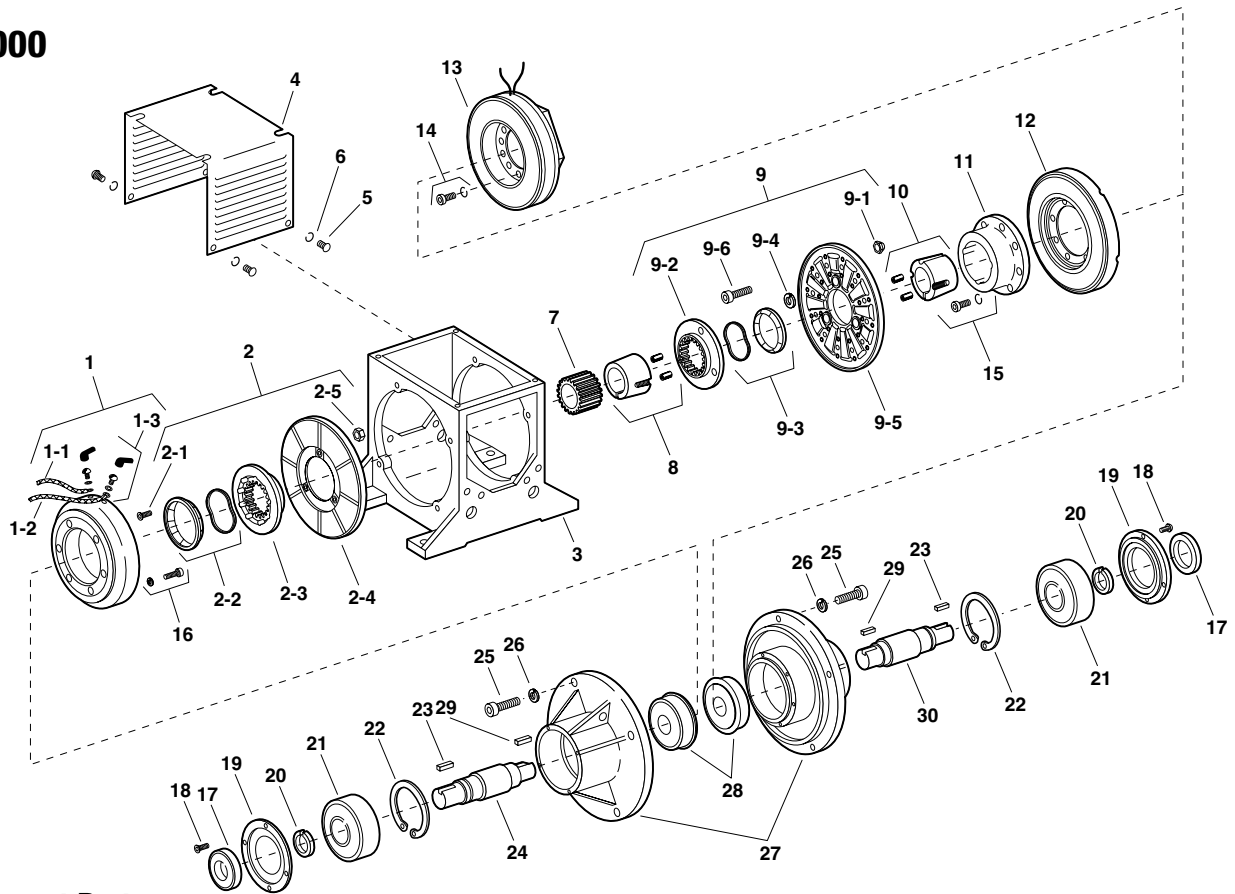

Component Parts

Item	Description	Part No.	Qty.
1	Magnet Assembly 6 volt 24 volt 90 volt	 5312-631-004 5312-631-005 5312-631-006	 1 1 1
1-1	Wire Assembly (Red)	5232-954-003	1
1-2	Wire Assembly (Black)	5232-954-004	1
1-3	Terminal Accessory	5311-101-001	1
2	Armature & Splined Adapter	5322-111-002	1
2-1	Button Head Screw	797-0272	1
2-2	Autocap Accessory	5322-101-004	1
2-3	Splined Arm, Adapter	104-0009	1
2-4	Armature	5322-111-036	1
2-5	Locknut	661-0004	3
3	Frame	174-0043	1
4	Dust Cover	287-0052	1
5	Button Head Screw	797-1175	8
6	Lockwasher	950-0103	8
7	Splined Armature Hub	540-0061	1
8	Bushing, 1-7/8" Bore	180-0177	1
9	Armature & Splined Adapter	5202-111-001	1
9-1	Locknut	661-0004	3
9-2	Splined Armature Adapter	104-0009	1
9-3	Autogap Accessory	5322-101-004	1
9-4	Spacer	748-0333	3
9-5	Armature	5322-111-036	1
9-6	Cap Screw	797-0341	3
10	Bushing, 2" Bore	180-0179	1
11	Rotor Hub	540-0315	1
12	Rotor	5202-751-003	1

Item	Description	Part No.	Qty.
13	Field Assembly 6 volt 24 volt 90 volt	 5202-451-004 5202-451-006 5202-451-007	 1 1 1
14	Mounting Accessory	5321-101-001	1
15	Mounting Accessory	5201-101-007	1
16	Mounting Accessory	5321-101-001	1
17	Oil Seal	795-0024	2
18	Button Head Screw	797-1008	8
19	Retainer Plate	686-0047	2
20	Retainer Ring – External	748-0504	2
21	Ball Bearing	166-0130	2
22	Retainer Ring – Internal	748-0375	2
23	Key	590-0024	2
24	Shaft, Brake	798-0026	1
25	Cap Screw	797-0361	8
26	Lockwasher	950-0362	8
27	Bearing Housing	535-0012	2
28	Ball Bearing	166-0131	2
29	Key	590-0025	2
30	Shaft, Clutch	798-0025	1
*NS	Clamp Wire Speed Nut	263-0016	2
*NS	Wire Assembly (Red)	5232-954-003	2
*NS	Wire Assembly (Black)	5232-954-004	2
*NS	Screws	797-1007	2
*NS	Insulator Bushing	572-0522	1
*NS - Not Shown			
These units meet the standards of UL508 and are listed under guide card #NMTR, file #59164. These units are CSA certified under file #LR11543			

EP-1525, EP-1525HT

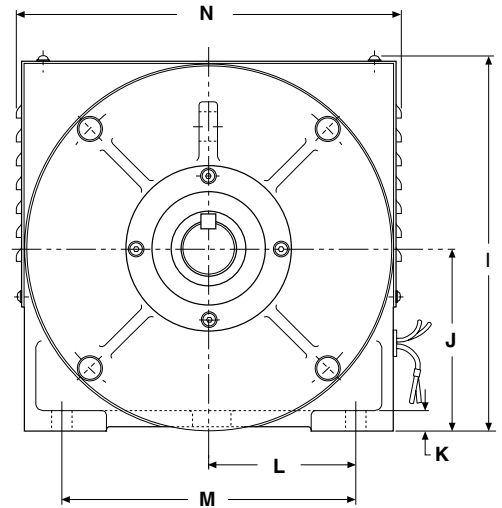
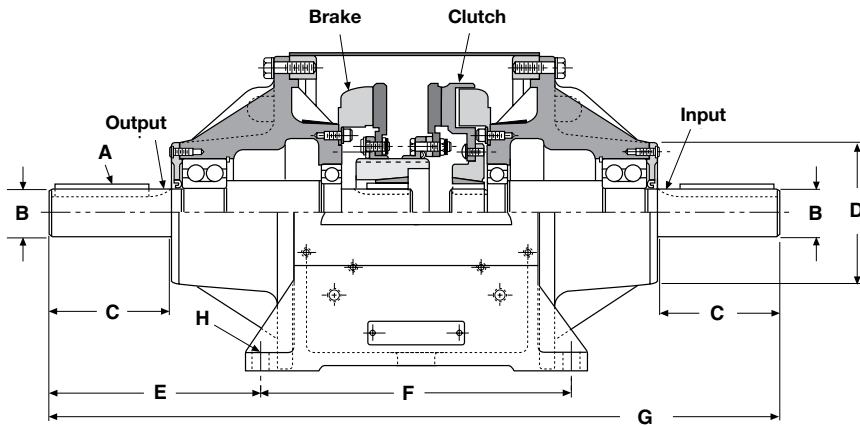

All dimensions are nominal, unless otherwise noted.

Size	A	B Dia.	C Min.	D Max. Dia.	E	F	G Max.	H	I	J	K	L	M	N Max.
1525	5/8 x 5/8 x 4-1/4	2.375 2.374	5.750	7.500	8.468	16.500	33.500	.796 Dia. (4 holes)	18.250	9.005 8.991	1.000	7.000	14.000	18.875
1525HT	5/8 x 5/8 x 4-1/4	2.375 2.374	5.750	7.500	8.468	16.500	33.500	.796 Dia. (4 holes)	18.250	9.005 8.991	1.000	7.000	14.000	18.875

Specifications

Model Size	Voltage DC	Unit	Static Torque lb.ft.	Inertia-WR ² lb.ft. ²		Max. RPM	Weight lbs.
				Output	Input		
EP-1525	6	Clutch	700	7.89	5.68	1800	655
		Brake	700				
-	90	Clutch	700	7.89	5.68	1800	655
		Brake	700				
EP-1525 HT	90	Clutch	1350	7.89	6.41	1800	656
		Brake	700				

EP-1525, EP-1525HT

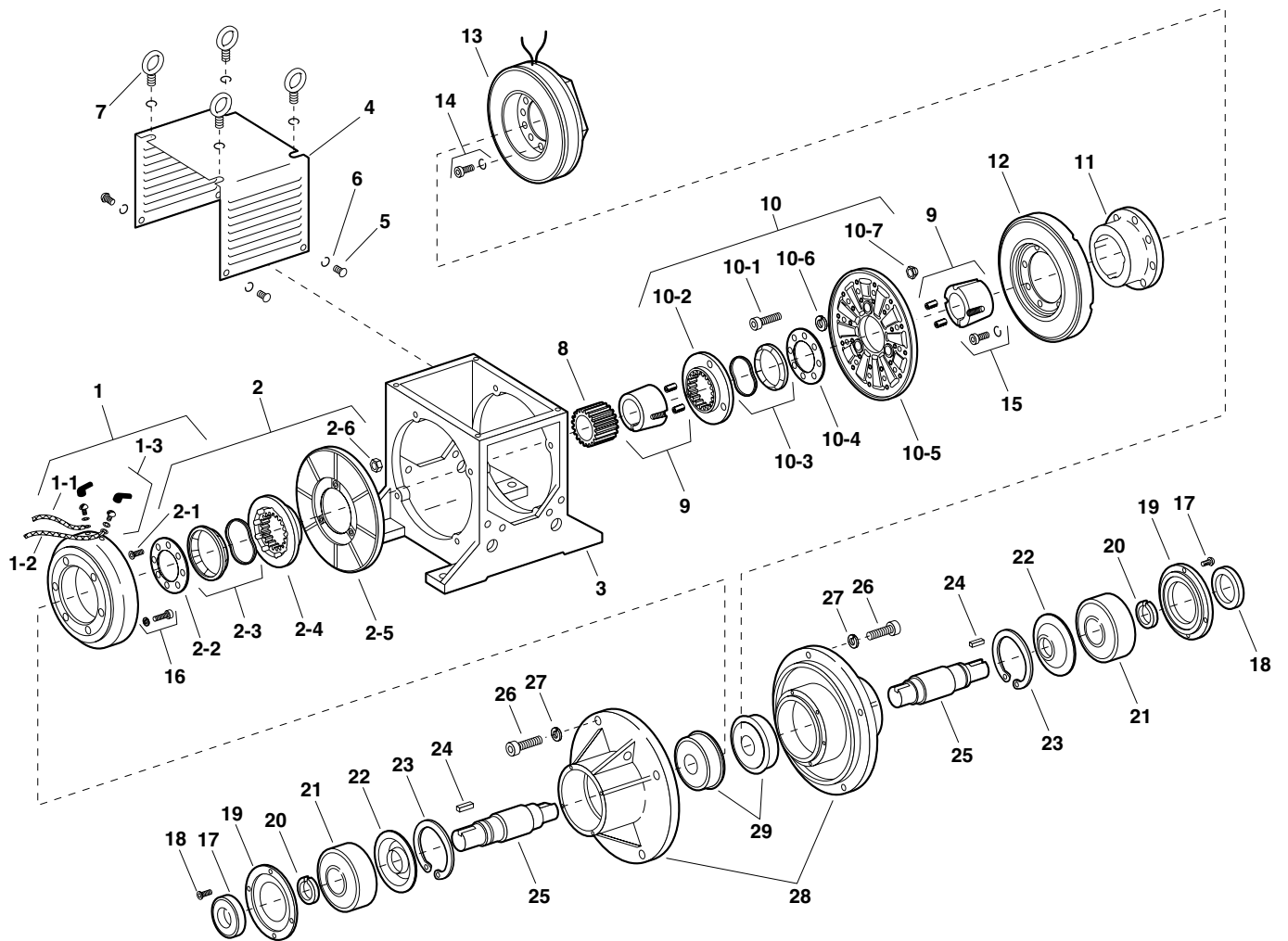

Component Parts

EP-1525, EP-1525HT

Item	Description	EP-1525		EP-1525HT	
		Part No.	Qty.	Part No.	Qty.
1	Magnet 6 volt 90 volt	5314-631-004 5314-631-005	1	5314-631-005	1
*1-1	Wire Assembly (Red)	5232-954-003	1	5232-954-003	1
*1-2	Wire Assembly (Black)	5232-954-004	1	5232-954-004	1
*1-3	Terminal Accessory	5311-101-001	1	5311-101-001	1
2	Armature & Splined Adapter	5324-111-001	1	5324-111-001	1
*2-1	Button Head Screw	797-0272	8	797-0272	8
*2-2	Armature Plate	686-0003	1	686-0003	1
*2-3	Autogap Accessory	5323-101-002	1	5323-101-002	1
*2-4	Splined Armature Adapter	104-0011	1	104-0011	1
*2-5	Armature	5324-111-034	1	5324-111-034	1
*2-6	Locknut	661-0004	8	661-0004	8
3	Frame	174-0044	1	174-0044	1
4	Dust Cover	287-1002	1	287-1002	1
5	Button Head Screw	797-1175	8	797-1175	8
6	Lock Washer	950-0103	8	950-0103	8
7	Eye Bolts	171-0006	4	171-0006	4
8	Splined Armature Hub	540-0063	1	540-0063	1
9	Bushing, 2-3/8" Bore	180-0215	2	180-0215	2
10	Armature & Splined Adapter	5204-111-004	1	5204-111-004	1
*10-1	Cap Screw	797-0342	8	797-0342	8
*10-2	Splined Armature Adapter	104-0011	1	104-0011	1
*10-3	Autogap Accessory	5323-101-002	1	5323-101-002	1
*10-4	Retainer Plate	686-0003	1	686-0003	1
*10-5	Armature	5324-111-034	1	5324-111-034	1
*10-6	Spacer	748-0333	8	748-0333	8
*10-7	Locknut	661-0004	8	661-0004	8
11	Rotor Hub	5234-541-001	1	5234-541-001	1
12	Rotor	5204-751-002	1	5204-751-001	1
13	Field Assembly 6 volt 90 volt	5204-451-013 5204-451-016	1	5204-451-006	1
14	Mounting Accessory	5321-101-002	2	5321-101-002	2
15	Mounting Accessory	5321-101-001	2	5321-101-001	2
16	Mounting Accessory	5321-101-001	2	5321-101-001	2
17	Screw	797-0294	8	797-0294	8
18	Oil Seal	795-0025	2	795-0025	2
19	Retainer Plate	686-0048	2	686-0048	2
20	Retaining Ring – External	748-0503	2	748-0503	2
21	Ball Bearing	166-0132	2	166-0132	2
22	Bearing Seal	795-0036	2	795-0036	2
23	Retainer Ring – Internal	748-0552	2	748-0052	2
24	Key	590-0028	2	590-0028	2
25	Shaft	798-0027	2	798-0027	2
26	Cap Screw	797-0362	12	797-0362	12
27	Lock Washer	950-0362	12	950-0362	12
28	Bearing Housing	535-0013	2	535-0013	2
29	Ball Bearing	166-0133	2	166-0133	2
**NS	Clamp Wire Speed Nut	263-0016	2		
**NS	Wire Assembly (Red)	5232-954-003	2		
**NS	Wire Assembly (Black)	5232-954-004	2		
**NS	Screws	797-1007	2		
**NS	Insulator Bushing	572-0522	1		

* Shipped Assembled

**NS - Not Shown

These units meet the standards of UL508 and are listed under guide card #NMTR, file #59164. These units are CSA certified under file #LR11543.

Warranty

Warner Electric LLC warrants that it will repair or replace (whichever it deems advisable) any product manufactured and sold by it which proves to be defective in material or workmanship within a period of one (1) year from the date of original purchase for consumer, commercial or industrial use.

This warranty extends only to the original purchaser and is not transferable or assignable without Warner Electric LLC's prior consent.

Warranty service can be obtained in the U.S.A. by returning any defective product, transportation charges prepaid, to the appropriate Warner Electric LLC factory. Additional warranty information may be obtained by writing the Customer Satisfaction Department, Warner Electric LLC, 449 Gardner Street, South Beloit, Illinois 61080, or by calling 815-389-3771.

A purchase receipt or other proof of original purchase will be required before warranty service is rendered. If found defective under the terms of this warranty, repair or replacement will be made, without charge, together with a refund for transportation costs. If found not to be defective, you will be notified and, with your consent, the item will be repaired or replaced and returned to you at your expense.

This warranty covers normal use and does not cover damage or defect which results from alteration, accident, neglect, or improper installation, operation, or maintenance.

Some states do not allow limitation on how long an implied warranty lasts, so the above limitation may not apply to you.

Warner Electric LLC's obligation under this warranty is limited to the repair or replacement of the defective product and in no event shall Warner Electric LLC be liable for consequential, indirect, or incidental damages of any kind incurred by reason of the manufacture, sale or use of any defective product. Warner Electric LLC neither assumes nor authorizes any other person to give any other warranty or to assume any other obligation or liability on its behalf.

WITH RESPECT TO CONSUMER USE OF THE PRODUCT, ANY IMPLIED WARRANTIES WHICH THE CONSUMER MAY HAVE ARE LIMITED IN DURATION TO ONE YEAR FROM THE DATE OF ORIGINAL CONSUMER PURCHASE. WITH RESPECT TO COMMERCIAL AND INDUSTRIAL USES OF THE PRODUCT, THE FOREGOING WARRANTY IS IN LIEU OF AND EXCLUDES ALL OTHER WARRANTIES, WHETHER EXPRESSED OR IMPLIED BY OPERATION OF LAW OR OTHERWISE, INCLUDING, BUT NOT LIMITED TO, ANY IMPLIED WARRANTIES OF MERCHANTABILITY OR FITNESS.

Some states do not allow the exclusion or limitation of incidental or consequential damages, so the above limitation or exclusion may not apply to you. This warranty gives you specific legal rights and you may also have other rights which vary from state to state.

Changes in Dimensions and Specifications

All dimensions and specifications shown in Warner Electric catalogs are subject to change without notice. Weights do not include weight of boxing for shipment. Certified prints will be furnished without charge on request to Warner Electric.



www.warnerelectric.com

31 Industrial Park Road
New Hartford, CT 06057
815-389-3771