

Warner Electric Compressor Clutch

Service & Installation Instructions

P-1373-WE
819-0072



 **Warner**[®]
Electric

An **Altra Industrial Motion** Company

⚠ WARNING Failure to follow these instructions may result in product damage, equipment damage, and serious or fatal injury to personnel.

General

This compressor clutch has been developed specifically for automobile air conditioning applications. Properly installed, it will provide maintenance free service. The clutch, using a stationary field principle, does not require slip rings or brushes.

The clutch consists of two major components, a stationary magnetic field assembly and a rotor-pulley assembly. The field assembly is mounted on bosses on the compressor. The rotor-pulley assembly is mounted to the compressor crankshaft and driven by V-belts from the engine crankshaft pulley. Electricity energizes the clutch field to couple the clutch magnetically, thus driving the compressor. Deenergization of the field releases the clutch and uncouples the compressor.

Installation

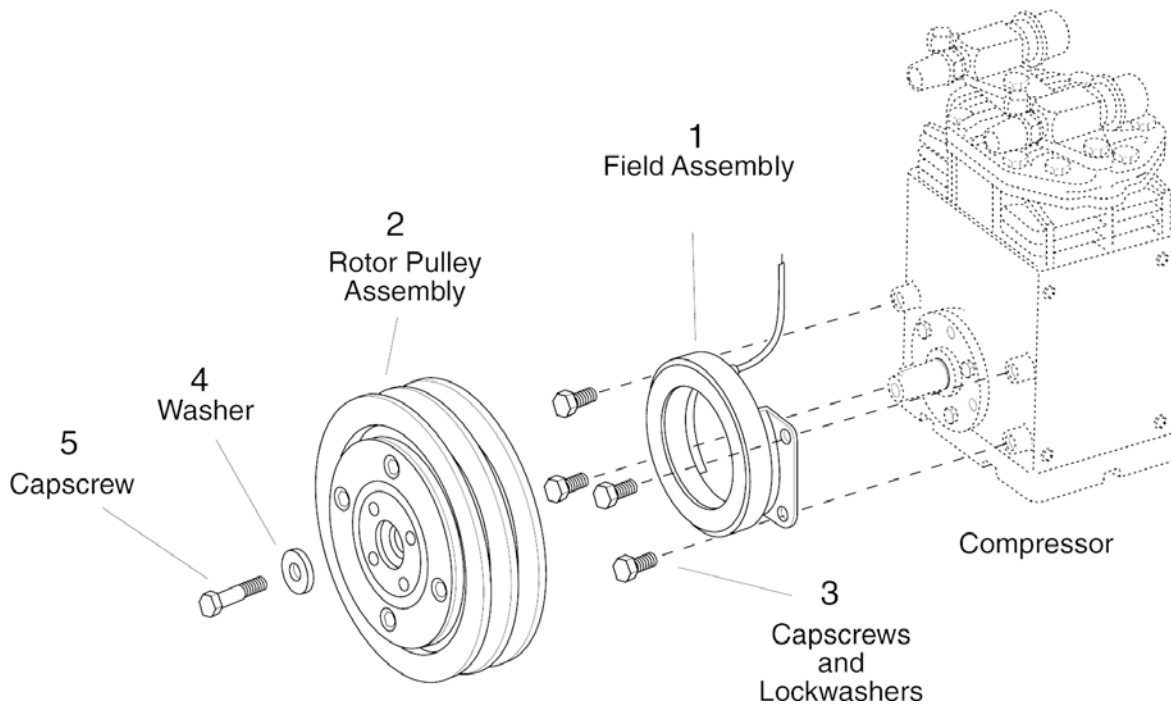

Wiring

The coil in the field assembly has a single leadwire (hot) and is grounded to the field shell. It will only be necessary to connect this leadwire into the electrical system as recommended by the manufacturer of the air conditioning unit. Figure 1 is an example of a typical system.

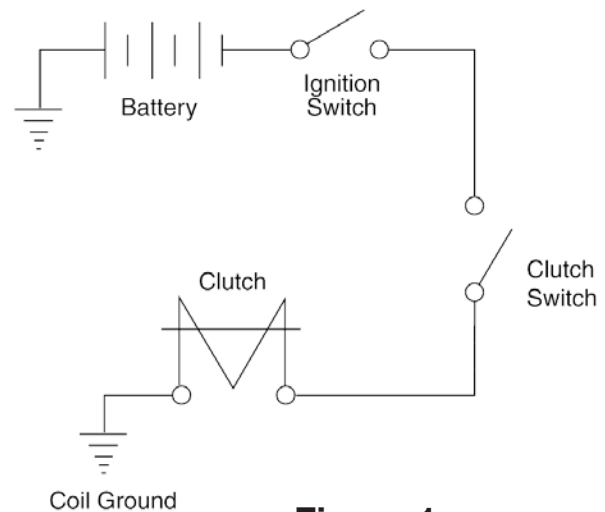

Figure 1

Step 1

Position the field assembly (1) against the compressor bosses, aligning the field mounting holes with the bolt holes in the bosses. Insert four capscrews and lockwashers (3) furnished with the clutch into the bolt holes of the compressor. Tighten the capscrews to a wrench torque of 7 - 10 ft./lbs. (85 - 120 in./lbs.). Use caution not to strip the threads in the compressor body.

Step 2

The compressor shaft must be clean and free from burrs. Check the woodruff key for proper position and seating.

Step 3

Slide the rotor pulley assembly (2) on to the tapered shaft (aligning the keyway with the woodruff key in the shaft). Secure the rotor pulley assembly with the washer (4) and selflocking capscrew (5) provided with the clutch. Tighten the self-locking capscrew to a wrench torque of 15 - 20 ft./lbs. (180 - 240 in./lbs.).

Step 4

Rotate the pulley assembly manually to assure that there is no interference between the field and rotor. If any interference occurs, a rubbing noise can be heard as the pulley rotates. In case of rubbing or other mechanical interference, disassemble the clutch and repeat the installation of the field assembly.

Step 5

To disassemble the rotor-pulley assembly from the compressor, remove the self-locking capscrew and washer and insert a 5/8-11 UNC-2B capscrew in the threaded portion of the hub. The pressure exerted by the capscrew on the end of the compressor shaft will force off the rotor pulley assembly without damage to the clutch or compressor. Do not use a wheel puller on the outer diameter of the pulley, as this can result in damage to the clutch bearing. Warranty voided if clutch is removed from shaft without using a 5/8-11 UNC bolt in the hub.

Step 6

Clutch Burnish - Install the belts per vehicle manufacturer specifications. Run the engine at 2000-2500 RPM and cycle the clutch ON and OFF at a rate of 10 to 15 times per minute for 50 cycles minimum. This procedure will help bring the clutch up to the operating torque capacity.

Note: To prevent electrical system damage, use the vehicle A/C controls to cycle the clutch.

Service

This compressor clutch automatically compensates for wear requiring no adjustment throughout the life of the clutch. Do not lubricate the unit. If the clutch should fail to operate, check the electrical circuit to be sure that the proper voltage is being supplied to the clutch. Do not attempt to make any mechanical adjustments on the clutch.

Warranty

Warner Electric LLC warrants that it will repair or replace (whichever it deems advisable) any product manufactured and sold by it which proves to be defective in material or workmanship within a period of one (1) year from the date of original purchase for consumer, commercial or industrial use.

This warranty extends only to the original purchaser and is not transferable or assignable without Warner Electric LLC's prior consent.

Warranty service can be obtained in the U.S.A. by returning any defective product, transportation charges prepaid, to the appropriate Warner Electric LLC factory. Additional warranty information may be obtained by writing the Customer Satisfaction Department, Warner Electric LLC, 449 Gardner Street, South Beloit, Illinois 61080, or by calling 815-389-3771.

A purchase receipt or other proof of original purchase will be required before warranty service is rendered. If found defective under the terms of this warranty, repair or replacement will be made, without charge, together with a refund for transportation costs. If found not to be defective, you will be notified and, with your consent, the item will be repaired or replaced and returned to you at your expense.

This warranty covers normal use and does not cover damage or defect which results from alteration, accident, neglect, or improper installation, operation, or maintenance.

Some states do not allow limitation on how long an implied warranty lasts, so the above limitation may not apply to you.

Warner Electric LLC's obligation under this warranty is limited to the repair or replacement of the defective product and in no event shall Warner Electric LLC be liable for consequential, indirect, or incidental damages of any kind incurred by reason of the manufacture, sale or use of any defective product. Warner Electric LLC neither assumes nor authorizes any other person to give any other warranty or to assume any other obligation or liability on its behalf.

WITH RESPECT TO CONSUMER USE OF THE PRODUCT, ANY IMPLIED WARRANTIES WHICH THE CONSUMER MAY HAVE ARE LIMITED IN DURATION TO ONE YEAR FROM THE DATE OF ORIGINAL CONSUMER PURCHASE. WITH RESPECT TO COMMERCIAL AND INDUSTRIAL USES OF THE PRODUCT, THE FOREGOING WARRANTY IS IN LIEU OF AND EXCLUDES ALL OTHER WARRANTIES, WHETHER EXPRESSED OR IMPLIED BY OPERATION OF LAW OR OTHERWISE, INCLUDING, BUT NOT LIMITED TO, ANY IMPLIED WARRANTIES OF MERCHANTABILITY OR FITNESS.

Some states do not allow the exclusion or limitation of incidental or consequential damages, so the above limitation or exclusion may not apply to you. This warranty gives you specific legal rights and you may also have other rights which vary from state to state.

Changes in Dimensions and Specifications

All dimensions and specifications shown in Warner Electric catalogs are subject to change without notice. Weights do not include weight of boxing for shipment. Certified prints will be furnished without charge on request to Warner Electric.



www.warnerelectric.com

4578 East Park 30 Drive
Columbia City, IN 46725
260-244-6183
Fax: 815-389-2582

An **Altra Industrial Motion** Company

