

# Autogap Installation for Sizes 825-1225 Motor Brakes

## Installation Instructions

**P-1375-WE**  
**819-0081**

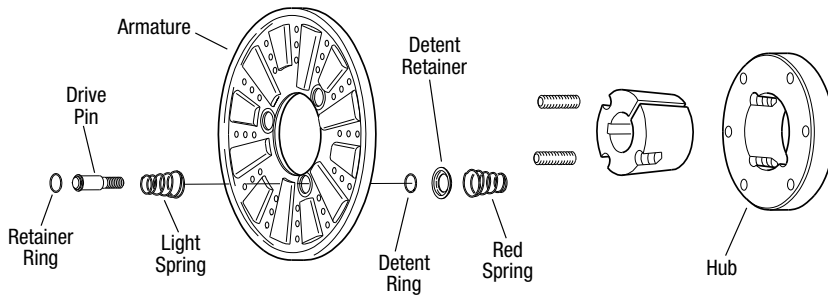

**⚠ WARNING** Failure to follow these instructions may result in product damage, equipment damage, and serious or fatal injury to personnel.

### Assembling the Armature and Hub

Assemble the armature to the armature hub with the autogap mounting accessory. Follow these instructions to assemble the armature and hub.

1. Apply Loctite® #242 (or #290, or equivalent) to drive pin threads. Insert the drive pin into the hub and tighten until the shoulder of the pin is against the hub. (Figure 1)
2. Assemble the red spring over the drive pin. The smaller diameter of the spring should be against the hub.
3. Place the detent retainer over the pin. The cupped-out portion should be against the spring. (Figure 2)
4. Place the detent ring on the pin and press it into the recessed portion of the detent retainer. (Figure 2)
5. Slide the detent ring towards the hub to allow about 1/2" between the ring and head of the pin. (Figure 3)
6. Slide the armature on the pins. The face of the armature should be towards the hub.

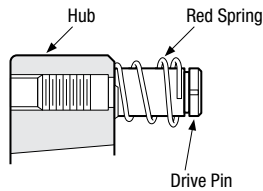

Figure 1

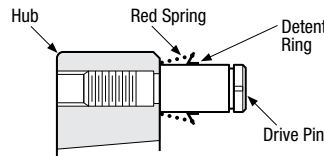

Figure 2

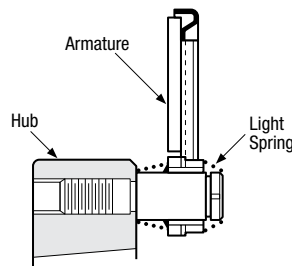

Figure 3

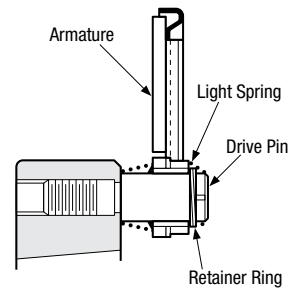

Figure 4

7. Assemble the light spring over the pin. The large diameter of the spring should be against the armature. (Figure 4)
8. Compress the spring to allow the retainer ring to be snapped into the groove at the head of the pin.

### Mounting the Armature-Hub Assembly (See Figure 5)

1. Insert taperlock bushing into the bore of the hub.
2. Loosely insert the locking setscrews and slide the assembly on to the shaft.
3. Position the assembly to allow a gap of 1/16" between the faces of the armature and magnet.
4. Secure the assembly in this position by alternately tightening the locking setscrews. The bushing should be tapped lightly from time-to-time to make sure it seats-in properly.
5. Set the autogap by pressing the armature into contact with the friction face and then releasing the armature. The armature should spring back approximately 1/32". Once this gap is set it will be automatically maintained throughout the life of the unit.
6. Use capscrews and lockwashers to bolt adapter cover.

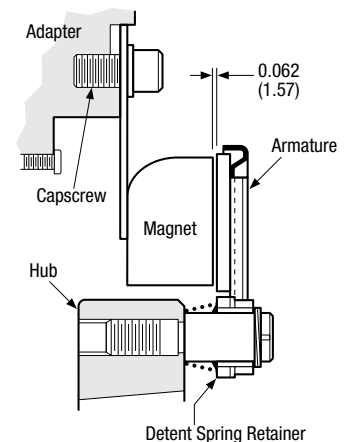

Figure 5

## Warranty

Warner Electric LLC warrants that it will repair or replace (whichever it deems advisable) any product manufactured and sold by it which proves to be defective in material or workmanship within a period of one (1) year from the date of original purchase for consumer, commercial or industrial use.

This warranty extends only to the original purchaser and is not transferable or assignable without Warner Electric LLC's prior consent.

Warranty service can be obtained in the U.S.A. by returning any defective product, transportation charges prepaid, to the appropriate Warner Electric LLC factory. Additional warranty information may be obtained by writing the Customer Satisfaction Department, Warner Electric LLC, 449 Gardner Street, South Beloit, Illinois 61080, or by calling 815-389-3771.

A purchase receipt or other proof of original purchase will be required before warranty service is rendered. If found defective under the terms of this warranty, repair or replacement will be made, without charge, together with a refund for transportation costs. If found not to be defective, you will be notified and, with your consent, the item will be repaired or replaced and returned to you at your expense.

This warranty covers normal use and does not cover damage or defect which results from alteration, accident, neglect, or improper installation, operation, or maintenance.

Some states do not allow limitation on how long an implied warranty lasts, so the above limitation may not apply to you.

Warner Electric LLC's obligation under this warranty is limited to the repair or replacement of the defective product and in no event shall Warner Electric LLC be liable for consequential, indirect, or incidental damages of any kind incurred by reason of the manufacture, sale or use of any defective product. Warner Electric LLC neither assumes nor authorizes any other person to give any other warranty or to assume any other obligation or liability on its behalf.

WITH RESPECT TO CONSUMER USE OF THE PRODUCT, ANY IMPLIED WARRANTIES WHICH THE CONSUMER MAY HAVE ARE LIMITED IN DURATION TO ONE YEAR FROM THE DATE OF ORIGINAL CONSUMER PURCHASE. WITH RESPECT TO COMMERCIAL AND INDUSTRIAL USES OF THE PRODUCT, THE FOREGOING WARRANTY IS IN LIEU OF AND EXCLUDES ALL OTHER WARRANTIES, WHETHER EXPRESSED OR IMPLIED BY OPERATION OF LAW OR OTHERWISE, INCLUDING, BUT NOT LIMITED TO, ANY IMPLIED WARRANTIES OF MERCHANTABILITY OR FITNESS.

Some states do not allow the exclusion or limitation of incidental or consequential damages, so the above limitation or exclusion may not apply to you. This warranty gives you specific legal rights and you may also have other rights which vary from state to state.

### Changes in Dimensions and Specifications

All dimensions and specifications shown in Warner Electric catalogs are subject to change without notice. Weights do not include weight of boxing for shipment. Certified prints will be furnished without charge on request to Warner Electric.



[www.warnerelectric.com](http://www.warnerelectric.com)

31 Industrial Park Road  
New Hartford, CT 06057  
815-389-3771  
Fax: 815-389-2582

An **Altra** Industrial Motion Company

