

# Conduit Box Kit No. 5200-101-012

## Installation Instructions

P-1393  
819-0200



**Warner**<sup>®</sup>  
*Electric*

*An Altra Industrial Motion Company*

## Components

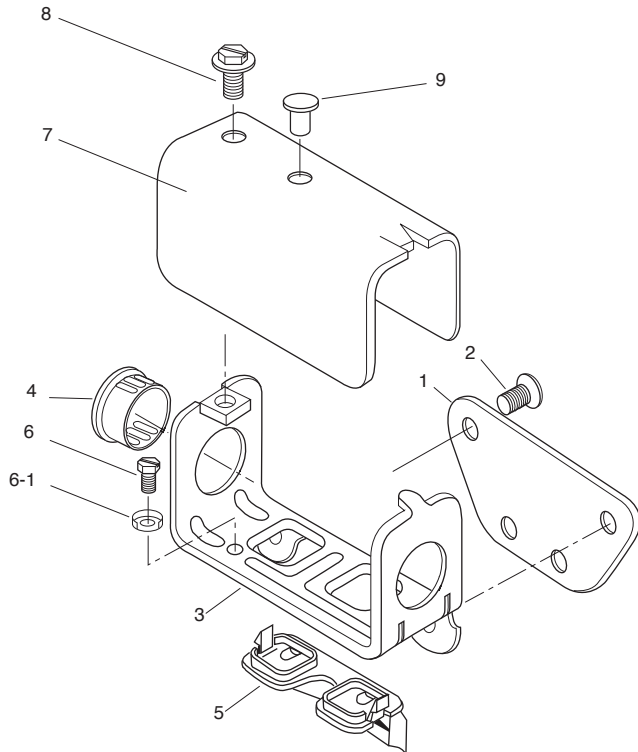

## Parts List for kit 5200-101-012

Item	Quantity	Part Name
1	1	Bracket
2	4	Screw, Flat Head
3	1	Box, Conduit
4	1	Plug, Protective
5	1	Retainer, Wire
6	1	Screw, Hex, Washer Head Green
6-1	1	Terminal, Ring
7	1	Cover
8	1	Screw, Hex, Washer Head
9	1	Plug, Protective

**Note: All mounting screws are self-tapping.**

## Introduction

Conduit box kit No. 5200-101-012 contains all components needed to assemble a conduit box for Warner Electric SF-825 through 1525 and EC-825 clutch fields. Wiring terminations are not provided. Consult local electrical codes for proper wiring terminations required. This conduit box will provide a proper means for wiring terminations and conforms to the requirements of Underwriters Laboratories.

**⚠ WARNING** Failure to follow these instructions may result in product damage, equipment damage, and serious or fatal injury to personnel.

**⚠ CAUTION** Do not connect rigid conduit directly to the conduit box. A minimum of 12" of flexible liquid tight conduit or other suitable flexible wiring with appropriate fittings is required. Flexible wiring is required to prevent side loading of bearing on bearing mounted clutches and possible deformation of the conduit box or components during assembly.

### Step 1

Assemble a customer supplied flexible wiring connector into the desired end of the conduit box (3). Press protective plug (4) into unused conduit hole.

Thread green washer head hex screw (6) into round hole in base of conduit box. Place terminal ring (6-1) over screw before inserting.

Insert wire retainer (5) into square holes in conduit box base. Insert wire retainer from the bottom of the conduit box, longest portion of retainer towards mounting flange. (See Figure 1)

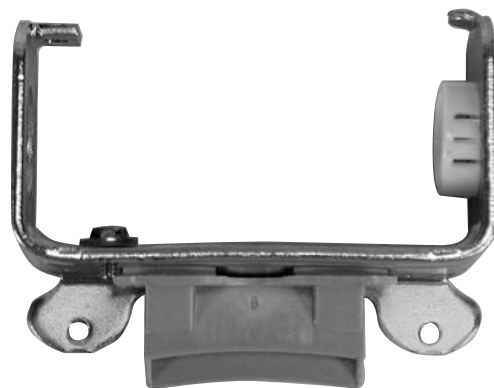

Figure 1

## Step 2

Follow either A or B, depending on field mounting:

### A. Inside Mounted Fields and Outside Mounted 825

Fasten bracket (1) to the back of the field by assembling two No. 10-32 undercut flat head machine screws (2) into the holes provided. Screws are self-tapping, holes in the field are not threaded. (See Figure 2)



Figure 2, Inside mount

### B. Outside Mounted Fields

Bracket (1) and two of the four flat head machine screws (2) are not required on these fields. (See Figure 3)



Figure 3, Outside Mount

## Step 3

Mount conduit box (3) to the bracket (1) on inside mount clutches, or to the mounting flange on outside mount clutches. Feed field wires through wire retainer before mounting conduit box. The conduit box must be on the front side of the bracket (1). Secure the box with two No. 10-32 undercut flat head machine screws (2). All flat head machine screws are inserted in the countersunk holes in the bracket or mounting plate. (See Figure 4)

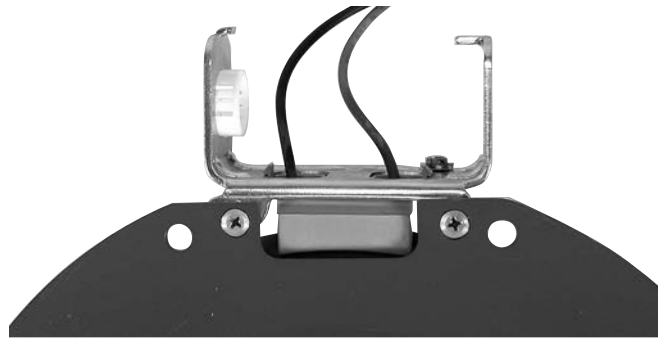

Figure 4

## Step 4

Connect electric supply cable to the fitting installed on the conduit box. If an external power supply is furnishing DC current to the clutch, proceed to Step 5 and skip Step 6. If a Warner Electric CBC-100 power supply is being installed in the conduit box, skip Step 5 and proceed to Step 6.

## Step 5 - DC Connection

Connect the two supply wires to the two lead wires from the clutch field with insulated wire nuts or other approved connectors. Connections must be insulated appropriately to meet local electrical codes. Install plug (9) into cover hole.

## Step 6 - AC Connection

If the two supply wires entering the conduit box are AC and the CBC-100 power supply is used, refer to installation sheet P-266 provided with the CBC-100, following instructions carefully. To mount the CBC-100 to the conduit box, place the control into the cover so the curved surfaces conform, line up the cover hole with the control mounting hole and fasten with screw provided in the mounting kit. Proper connection of wires is important for proper service.

## Step 7

A ground wire is recommended for grounding of the conduit box and clutch field. Connect this wire with the green ground screw (6) to the hole in the floor of the box. Consult local codes regarding grounding requirements.

## Step 8

Install cover (7) by sliding the slot in the cover over the tab on one end of the conduit box and secure the cover on the opposite end with one No. 10-32 hex washer head screw (8).

# Warranty

Warner Electric LLC warrants that it will repair or replace (whichever it deems advisable) any product manufactured and sold by it which proves to be defective in material or workmanship within a period of one (1) year from the date of original purchase for consumer, commercial or industrial use.

This warranty extends only to the original purchaser and is not transferable or assignable without Warner Electric LLC's prior consent.

Warranty service can be obtained in the U.S.A. by returning any defective product, transportation charges prepaid, to the appropriate Warner Electric LLC factory. Additional warranty information may be obtained by writing the Customer Satisfaction Department, Warner Electric LLC, 449 Gardner Street, South Beloit, Illinois 61080, or by calling 815-389-3771.

A purchase receipt or other proof of original purchase will be required before warranty service is rendered. If found defective under the terms of this warranty, repair or replacement will be made, without charge, together with a refund for transportation costs. If found not to be defective, you will be notified and, with your consent, the item will be repaired or replaced and returned to you at your expense.

This warranty covers normal use and does not cover damage or defect which results from alteration, accident, neglect, or improper installation, operation, or maintenance.

Some states do not allow limitation on how long an implied warranty lasts, so the above limitation may not apply to you.

Warner Electric LLC's obligation under this warranty is limited to the repair or replacement of the defective product and in no event shall Warner Electric LLC be liable for consequential, indirect, or incidental damages of any kind incurred by reason of the manufacture, sale or use of any defective product. Warner Electric LLC neither assumes nor authorizes any other person to give any other warranty or to assume any other obligation or liability on its behalf.

WITH RESPECT TO CONSUMER USE OF THE PRODUCT, ANY IMPLIED WARRANTIES WHICH THE CONSUMER MAY HAVE ARE LIMITED IN DURATION TO ONE YEAR FROM THE DATE OF ORIGINAL CONSUMER PURCHASE. WITH RESPECT TO COMMERCIAL AND INDUSTRIAL USES OF THE PRODUCT, THE FOREGOING WARRANTY IS IN LIEU OF AND EXCLUDES ALL OTHER WARRANTIES, WHETHER EXPRESSED OR IMPLIED BY OPERATION OF LAW OR OTHERWISE, INCLUDING, BUT NOT LIMITED TO, ANY IMPLIED WARRANTIES OF MERCHANTABILITY OR FITNESS.

Some states do not allow the exclusion or limitation of incidental or consequential damages, so the above limitation or exclusion may not apply to you. This warranty gives you specific legal rights and you may also have other rights which vary from state to state.

## **Changes in Dimensions and Specifications**

All dimensions and specifications shown in Warner Electric catalogs are subject to change without notice. Weights do not include weight of boxing for shipment. Certified prints will be furnished without charge on request to Warner Electric.



**Warner Electric**  
31 Industrial Road • New Hartford, CT 06057  
815-389-3771 • Fax: 815-389-2582  
[www.warnerelectric.com](http://www.warnerelectric.com)