

Pump Clutch Installation

Installation Instructions

P-1423-WE
819-0388

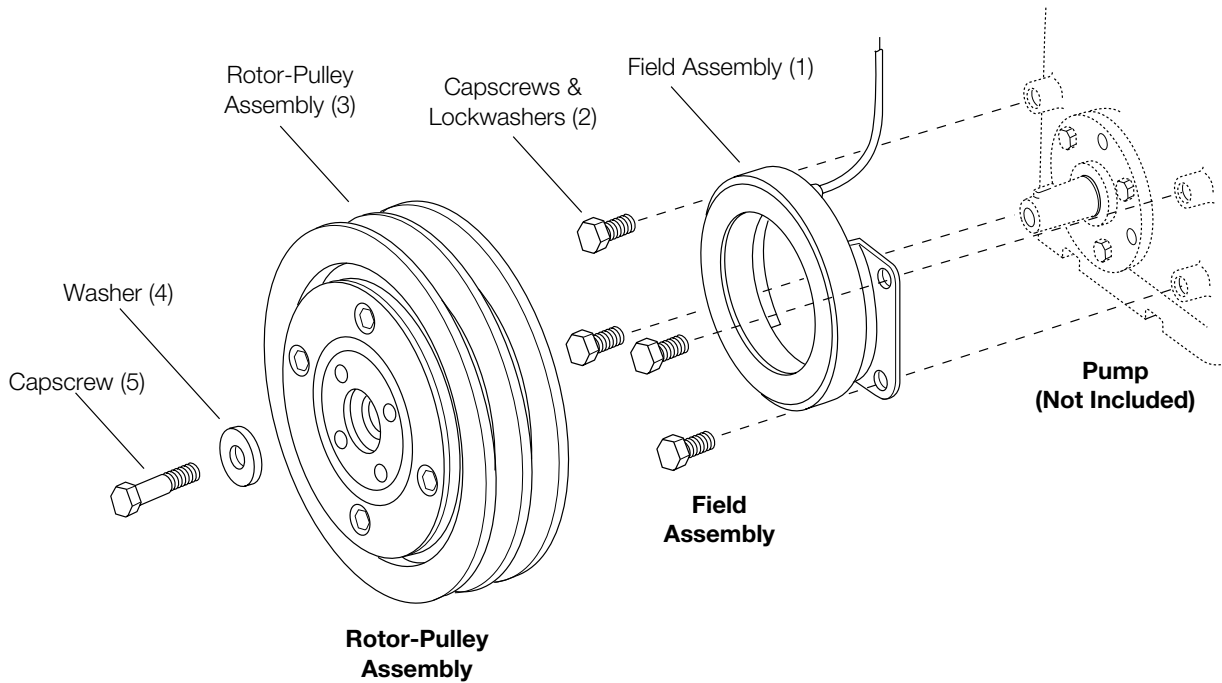



CAUTION Failure to follow these instructions may result in product damage, equipment damage, and serious or fatal injury to personnel.

General

This pump clutch has been developed specifically for use in pump applications. Properly installed, it will provide maintenance-free service. The clutch uses a stationary field that does not require slip rings or brushes.

The clutch consists of two major components; a stationary magnetic field assembly and a rotor-pulley assembly. The field assembly is mounted on the pump face. The rotor-pulley is mounted to the pump shaft and driven by v-belts. Electricity energizes the clutch field to couple the clutch magnetically, thus driving the pump mechanism. De-energizing the field releases the clutch and uncouples the pump.

Wiring

The coil in the field assembly has a single leadwire (hot) and is grounded through the field shell. It will only be necessary to connect this leadwire to the electrical system as the pump should already be negatively grounded. Figure 1 shows an example of a typical system.

Service

The clutch automatically compensates for wear requiring no adjustments throughout the life of the clutch. **Do not** lubricate the unit. If the clutch should fail to operate, check the electrical circuit to be sure the proper voltage is being supplied to the clutch. **Do not** attempt to make any mechanical adjustments to the clutch.

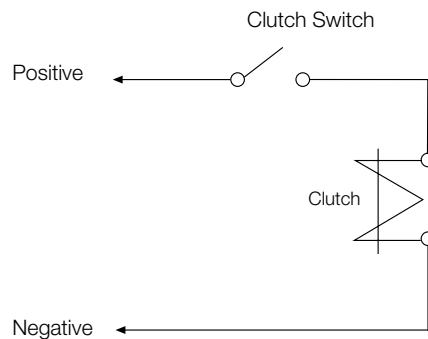

Figure 1

Installation

Diagnose Clutch Failure

Most clutch failures are a direct result of a system problem or failure. Before installing a new clutch, determine what caused the old clutch to fail and fix the system problem. By simply replacing the clutch without fixing the cause of the clutch failure, the new clutch may fail in the same manner as the old clutch.

Step 1

Position the field assembly (1) against the face of the pump and align the field mounting holes with those in the pump. Insert four capscrews into the bolt holes. Tighten the capscrews to a wrench torque of 7-10 lb.ft. (85-120 lb.in.).

▲CAUTION Use care not to strip the threads in the pump body.

Step 2

The pump shaft must be clean and free of burrs. Check the shaft key for proper position and seating.

Step 3

Slide the rotor-pulley assembly (3) onto the tapered shaft (aligning the key and the keyway). Secure the rotor-pulley assembly using the washer (4) and self-locking capscrew (5) provided with the clutch. Tighten the capscrew to a wrench torque of 15-20 lb.ft. (180-240 lb.in.)

Step 4

Rotate the rotor-pulley manually to ensure there is no interference between the field and the rotor-pulley. If any interference occurs, a rubbing/scrapping noise will be heard as the pulley rotates. If rubbing or some other mechanical interference does occur, disassemble the clutch (per step 5) and repeat assembly of the field assembly to the pump.

Step 5 (If Required)

To remove the rotor-pulley from the pump shaft, remove the self-locking capscrew (5) and washer (4). Then, insert a 5/8-11 UNC capscrew (not provided) into the center hole of the rotor. Rotate the screw against the pump shaft until the rotor breaks loose from the shaft.

▲CAUTION Do not use a wheel puller on the outer diameter of the pulley as this can damage the clutch bearing. Warranty will be voided if clutch is removed without using the 5/8-11 UNC threaded hole provided in the hub center.

Step 6 Clutch Burnish Procedure

Install drive belts as required by pump design. Run the pump at normal operating speed and cycle the clutch on and off at a rate of 10 to 15 times per minute for 50 cycles minimum. This procedure will help bring the clutch up to operating torque capacity.

Note: To prevent electrical system damage, use the pump clutch control to cycle the clutch.

Warranty

Warner Electric LLC warrants that it will repair or replace (whichever it deems advisable) any product manufactured and sold by it which proves to be defective in material or workmanship within a period of one (1) year from the date of original purchase for consumer, commercial or industrial use.

This warranty extends only to the original purchaser and is not transferable or assignable without Warner Electric LLC's prior consent.

Warranty service can be obtained in the U.S.A. by returning any defective product, transportation charges prepaid, to the appropriate Warner Electric LLC factory. Additional warranty information may be obtained by writing the Customer Satisfaction Department, Warner Electric LLC, 449 Gardner Street, South Beloit, Illinois 61080, or by calling 815-389-3771.

A purchase receipt or other proof of original purchase will be required before warranty service is rendered. If found defective under the terms of this warranty, repair or replacement will be made, without charge, together with a refund for transportation costs. If found not to be defective, you will be notified and, with your consent, the item will be repaired or replaced and returned to you at your expense.

This warranty covers normal use and does not cover damage or defect which results from alteration, accident, neglect, or improper installation, operation, or maintenance.

Some states do not allow limitation on how long an implied warranty lasts, so the above limitation may not apply to you.

Warner Electric LLC's obligation under this warranty is limited to the repair or replacement of the defective product and in no event shall Warner Electric LLC be liable for consequential, indirect, or incidental damages of any kind incurred by reason of the manufacture, sale or use of any defective product. Warner Electric LLC neither assumes nor authorizes any other person to give any other warranty or to assume any other obligation or liability on its behalf.

WITH RESPECT TO CONSUMER USE OF THE PRODUCT, ANY IMPLIED WARRANTIES WHICH THE CONSUMER MAY HAVE ARE LIMITED IN DURATION TO ONE YEAR FROM THE DATE OF ORIGINAL CONSUMER PURCHASE. WITH RESPECT TO COMMERCIAL AND INDUSTRIAL USES OF THE PRODUCT, THE FOREGOING WARRANTY IS IN LIEU OF AND EXCLUDES ALL OTHER WARRANTIES, WHETHER EXPRESSED OR IMPLIED BY OPERATION OF LAW OR OTHERWISE, INCLUDING, BUT NOT LIMITED TO, ANY IMPLIED WARRANTIES OF MERCHANTABILITY OR FITNESS.

Some states do not allow the exclusion or limitation of incidental or consequential damages, so the above limitation or exclusion may not apply to you. This warranty gives you specific legal rights and you may also have other rights which vary from state to state.

Changes in Dimensions and Specifications

All dimensions and specifications shown in Warner Electric catalogs are subject to change without notice. Weights do not include weight of boxing for shipment. Certified prints will be furnished without charge on request to Warner Electric.



www.WarnerPTODirect.com

4578 East Park 30 Drive
Columbia City, IN 46725
888-274-3718