

Safety Interlock Switch

P- 1488
819- 0467

Installation & Operating Instructions

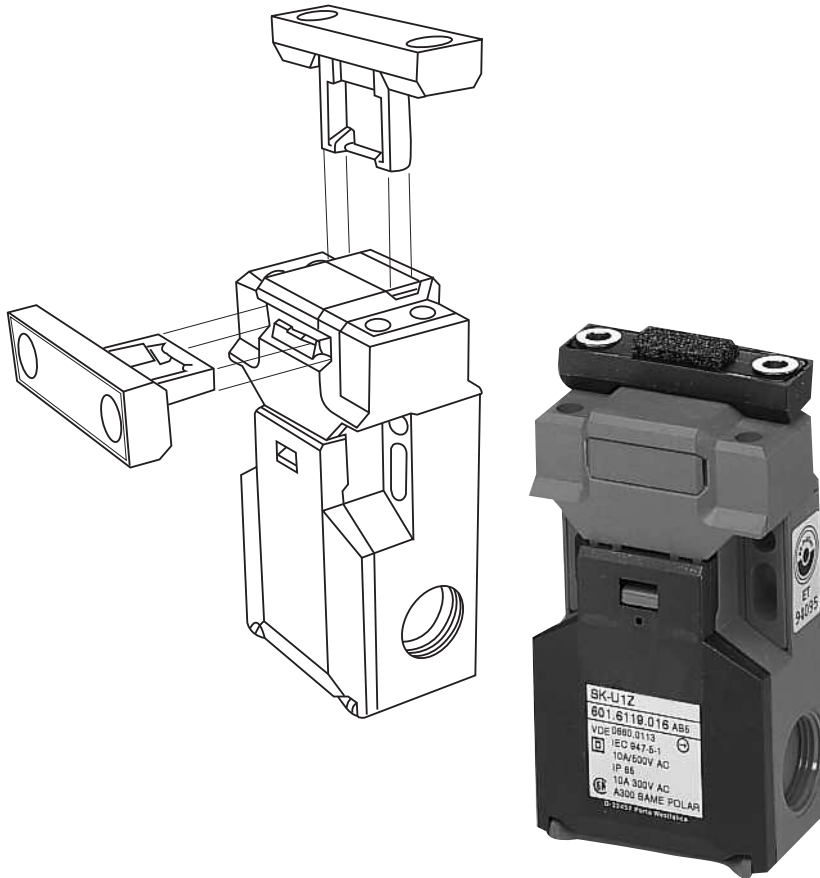

An Altra Industrial Motion Company

Contents

Description	2
Features	2
Mechanical Features	2
Electrical Features	6
Actuation Directions	3
Mechanical/Dimensions	3
Switching Diagram	3
Contact Operation	3
Threaded entrance Holes	3
Actuator Mounting	3
Warranty	Back Page

⚠ WARNING Failure to follow these instructions may result in product damage, equipment damage, and serious or fatal injury to personnel.

MECHANICAL FEATURES

Enclosure:	Thermoplastic, glass fiber reinforced
Actuator:	Separate Actuator, Aluminum (M5 dia. mounting holes) with plastic snap cover
Switch Mounting:	2 x M5 round and 2 x M5 elongated holes
Operational Temperature:	-30°C/+80°C -22°F/+176°F
Contact Type:	1 N.O. - 1 N.C. with forced disconnect of N.C. contacts
Mechanical Life:	1 million switch operations
Protection:	IP 65/Nema 4
Termination:	4 screw terminal connections M3.5 Screws

ELECTRICAL FEATURES

Rated voltage:	= 500V AC Max
Rated current:	= 10 A max. sustained current
CSA:	10A, 300VAC, A300, Same polarity

Utilization Categories per IEC 945-5-1,
AC = 15
DC = 13

APPROVALS



STANDARDS

VDE 0113
VDE 0660 Part 200
IEC 947-5-1
GS-ET 15

Description

Safety Switch with positive opening normally closed contacts which can only be activated with a specially designed mating key that protects against unintended operation.

Features

- Easy installation
- Actuator head can be oriented to 4 different approach directions quickly and easily
- Positive opening of the normally closed contacts for safety
- UL listed
- NEMA-4 rating
- Easy wiring access
- 3 cable entry holes with M20X1.5 threads
- 1/2" NPT conduit adaptor supplied with switch - part # 104-8001-004
- Strain relief adaptors are available to order - part # 280-8035-002

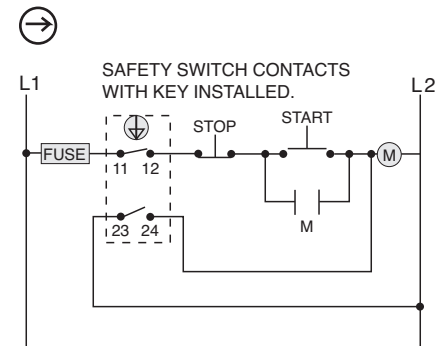

Special wiring for the safety-interlock switch to prevent tampering. The N.O contact 23-24 short circuits the coil of motor starter (M) with key removed. If the N.C. contact 11-12 were jumpered, the fuse would blow when the key is removed from the switch and an attempt is made to restart the circuit.

NOTE: Fuse to be 10 Amp slow acting or 16 Amp fast acting type.

Actuation Directions

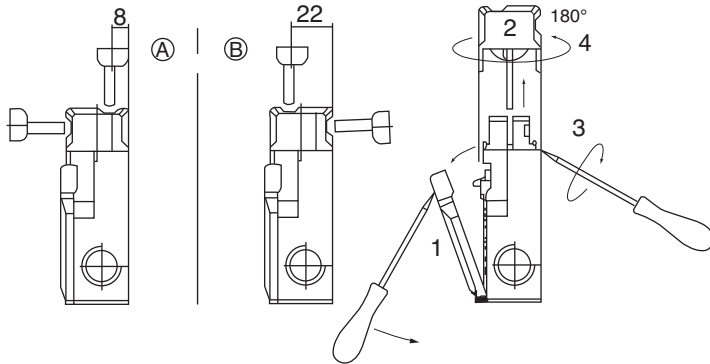

- 4 approach directions by changing the cap's position A or B.
- Cover 1 has to be opened before changing cap 2.
- Insert the screwdriver point into the separable gap housing and rotate screwdriver (until the cap unlocks) 3.
- Remove the cap and according to picture 4 turn around 180°, to put into housing and close the cover to lock cap.
- Radial actuation will reduce the mechanical life of the switch. Observe the minimum radius as shown in the Actuator Mounting directions.
- Unused key slots covered with plastic insert.

Mechanical/Dimensions mm

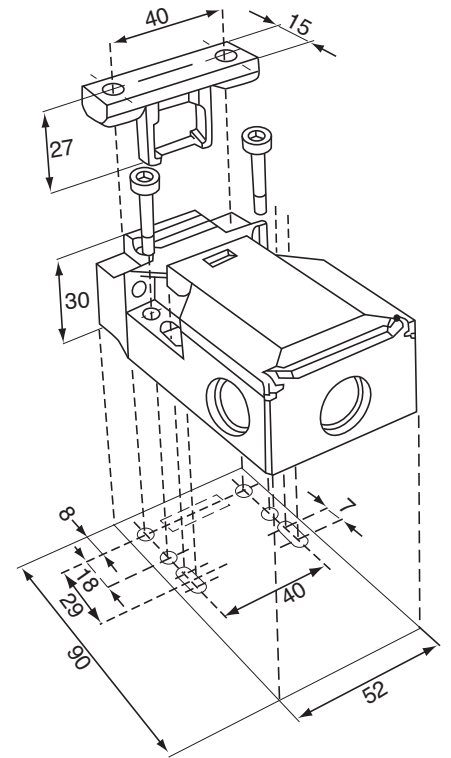

mm x .0394 = inches

Switching Diagram

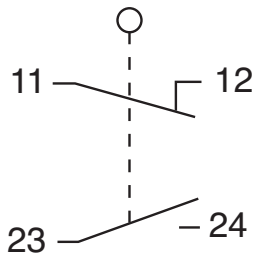

Contact Operation

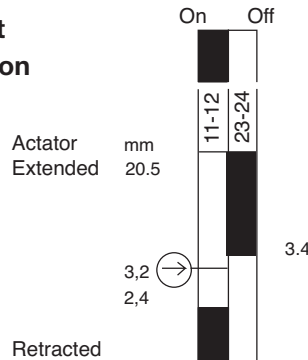

Threaded Entrance Holes M20 Threads

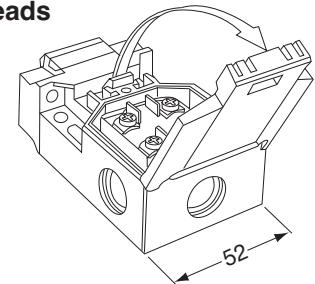

Supplied with 1/2" NPT Conduit Adaptor

Actuator Mounting

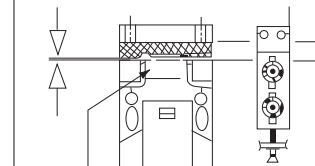
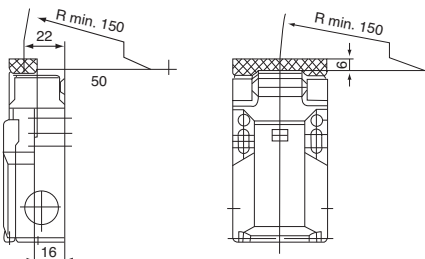
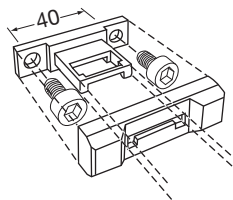

Don't use the switch as stop.

Warranty

Warner Electric LLC warrants that it will repair or replace (whichever it deems advisable) any product manufactured and sold by it which proves to be defective in material or workmanship within a period of one (1) year from the date of original purchase for consumer, commercial or industrial use.

This warranty extends only to the original purchaser and is not transferable or assignable without Warner Electric LLC's prior consent.

Warranty service can be obtained in the U.S.A. by returning any defective product, transportation charges prepaid, to the appropriate Warner Electric LLC factory. Additional warranty information may be obtained by writing the Customer Satisfaction Department, Warner Electric LLC, 449 Gardner Street, South Beloit, Illinois 61080, or by calling 815-389-3771.

A purchase receipt or other proof of original purchase will be required before warranty service is rendered. If found defective under the terms of this warranty, repair or replacement will be made, without charge, together with a refund for transportation costs. If found not to be defective, you will be notified and, with your consent, the item will be repaired or replaced and returned to you at your expense.

This warranty covers normal use and does not cover damage or defect which results from alteration, accident, neglect, or improper installation, operation, or maintenance.

Some states do not allow limitation on how long an implied warranty lasts, so the above limitation may not apply to you.

Warner Electric LLC's obligation under this warranty is limited to the repair or replacement of the defective product and in no event shall Warner Electric LLC be liable for consequential, indirect, or incidental damages of any kind incurred by reason of the manufacture, sale or use of any defective product. Warner Electric LLC neither assumes nor authorizes any other person to give any other warranty or to assume any other obligation or liability on its behalf.

WITH RESPECT TO CONSUMER USE OF THE PRODUCT, ANY IMPLIED WARRANTIES WHICH THE CONSUMER MAY HAVE ARE LIMITED IN DURATION TO ONE YEAR FROM THE DATE OF ORIGINAL CONSUMER PURCHASE. WITH RESPECT TO COMMERCIAL AND INDUSTRIAL USES OF THE PRODUCT, THE FOREGOING WARRANTY IS IN LIEU OF AND EXCLUDES ALL OTHER WARRANTIES, WHETHER EXPRESSED OR IMPLIED BY OPERATION OF LAW OR OTHERWISE, INCLUDING, BUT NOT LIMITED TO, ANY IMPLIED WARRANTIES OF MERCHANTABILITY OR FITNESS.

Some states do not allow the exclusion or limitation of incidental or consequential damages, so the above limitation or exclusion may not apply to you. This warranty gives you specific legal rights and you may also have other rights which vary from state to state.

Changes in Dimensions and Specifications

All dimensions and specifications shown in Warner Electric catalogs are subject to change without notice. Weights do not include weight of boxing for shipment. Certified prints will be furnished without charge on request to Warner Electric.



Warner Electric
31 Industrial Park Road • New Hartford, CT 06057
815-389-3771 • Fax: 815-389-2582
www.warnerelectric.com