

Washdown Electro-Packs EP-250-W, EP-400-W Foot Mounted Clutch/Brakes

P-1510
819-0475

Installation Instructions



Contents

Product Description	2
Installation Instructions	3
Electrical Connections.	3
Burnishing	3
Maintenance	3
Servicing Worn Components	3
Troubleshooting	4
Clutch/Brake Selection Information	
Horsepower vs. Shaft Speed	5
Part Numbers	5
Mechanical Specifications	5
Electrical Coil Data.	5
Dimensions	5
Warranty	Back Page

⚠ WARNING Failure to follow these instructions may result in product damage, equipment damage, and serious or fatal injury to personnel.

Base Mounted Clutch/Brake Combinations in a Rugged Washdown Housing

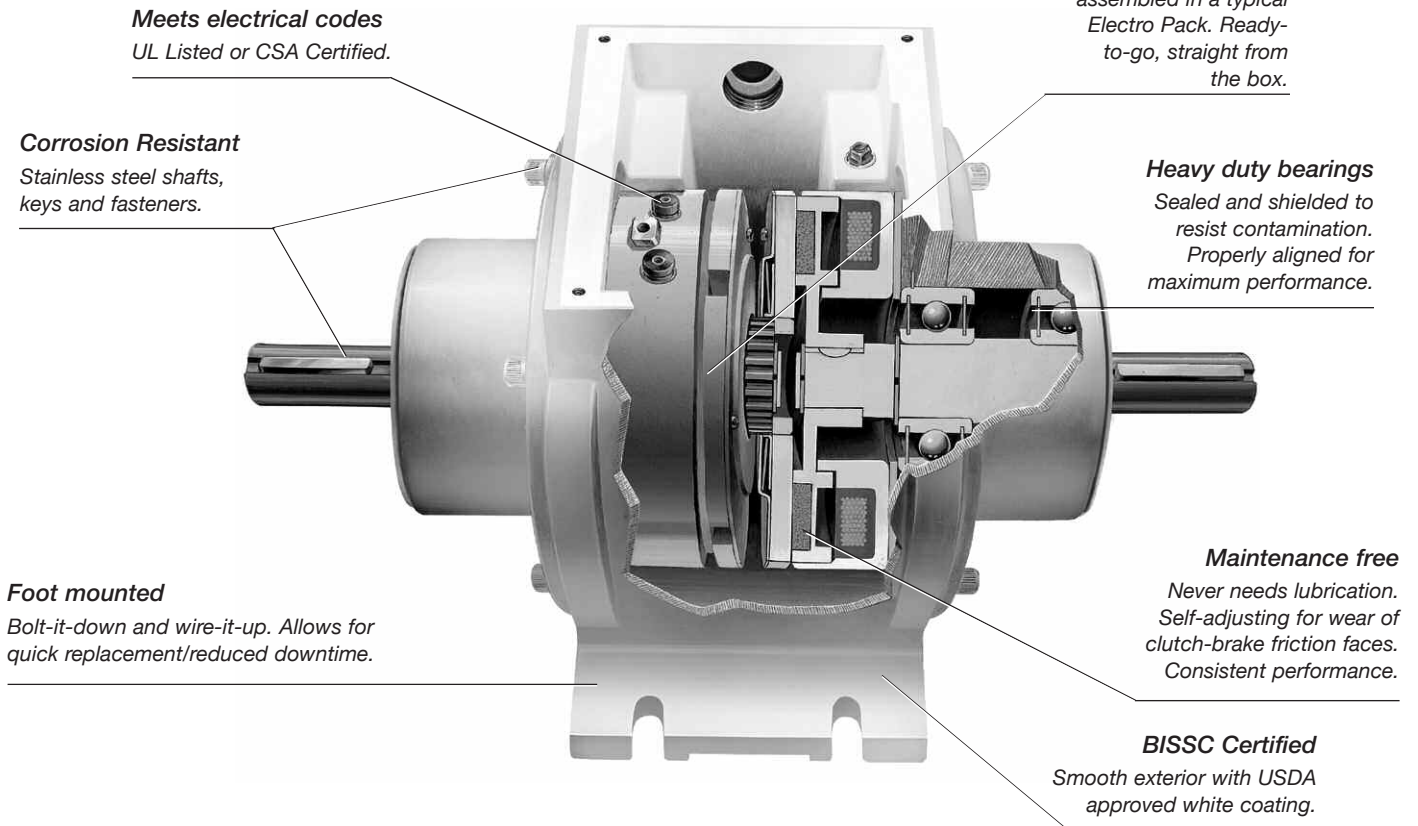

Product Description

The Washdown Electro-Pack (EP-W) is a pre-assembled foot mounted clutch/brake package complete with input and output shafts. EP-Ws are specifically designed for applications that require washing with high-pressure spray systems. Their smooth exterior reduces the accumulation of food particles or other contaminants, which can cause bacteria growth. They are coated with a USDA approved nontoxic white paint that is extremely resistant to chipping and corrosion. All fasteners, shafts, and keys are made from stainless steel to prevent corrosion, and the bearings are sealed and shielded to prevent contamination during washdown.

EP-Ws are ready to be installed in all standard power transmission systems using V-belts and pulleys, chains and sprockets, in-line couplings, timing belt drives, or gear trains.

Installation Instructions

1. Review the selection procedure on page 5 to determine if the selected Washdown Electro-Pack (EP-W) is the appropriate size and voltage for the intended application.
2. Identify the input end of the EP-W by locating the word "INPUT" cast into the side of the housing.
3. Mount the EP-W to a rigid surface that is flat within the following tolerances. Position the input end toward the intended drive system input.

Electro-Pack Size	Mounting Surface Flatness
250	.004"
400	.004"

4. Attach the drive system hardware to the input and output shafts of the EP-W. Be sure to connect the power input to the input shaft of the unit. Serious system damage may occur if the power input is connected to the EP-W output shaft. See page 5 for shaft dimensions.

Electrical Connection

⚠ WARNING All electrical current must be off when making electrical connections to prevent injury or death which can result from contact with live wires.

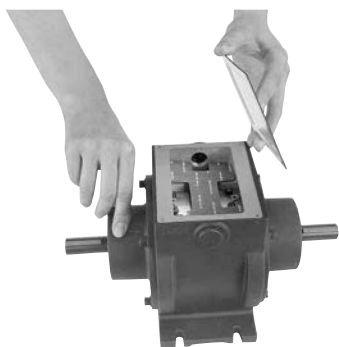

Figure 1

1. Remove the four screws and cover from the top of the EP-W to gain access to the electrical terminals on the clutch field and brake magnet. (Figure 1)
2. Feed lead wires through one of the two 1/2" conduit holes in the side of the EP-W housing.
3. Using the provided wire terminals, make the proper electrical connections between the EP-W and a suitable DC power supply. Refer to Figure 2 for typical EP-W connections. Polarity is not important when wiring Electro-Pack units.

Warner Electric offers a full line of AC input, DC output controls to meet the needs of most clutch/brake applications. The service and installation instructions included with each control show the proper connections.

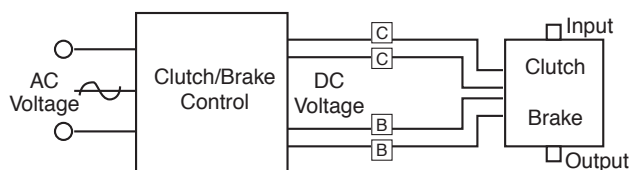

Figure 2

4. Replace the cover and four screws.

Burnishing

To obtain optimum Electro-Pack performance, a wear-in process called burnishing is required between the clutch and brake friction faces within the unit. Warner Electric Electro-Packs are burnished at the factory, eliminating the need to burnish the unit upon installation.

Maintenance

Properly applied and installed Electro-Packs do not require service, lubrication, or maintenance. The Washdown EP is designed to withstand limited exposure to high ambient temperatures and high-pressure wash systems, however optimum appearance and wear life will be obtained if this type of exposure is minimized.

Servicing Worn Components

The normal wearing components of an Electro-Pack are the brake magnet/armature, and the clutch rotor/armature. Since special tools are required to service these components, Warner Electric does not recommend user service of the

units. For more information contact your Warner Electric distributor, or call Warner Electric at 1-800-234-3369.

Troubleshooting

Problem	Possible Cause	Correction
Clutch or brake fails to engage.	No or insufficient DC power supplied to clutch or brake coils.	Remove the EP-W cover, turn on the electrical power to the terminals, and check the voltage across each pair of terminals. The voltage at the terminals should be within 5% of the units rated voltage. If not, adjust or change the power supply to obtain the rated voltage.
	Incorrect coil resistance.	Remove the EP-W cover, disconnect the lead wires from the terminals on the clutch and brake coils, and measure the resistance of each coil with an appropriate ohmmeter. Both resistance measurements should be within 10% of the values listed in the Electrical Specifications of this instruction sheet. If not, replace the EP-W with a new unit.
	Clutch or brake air gap out of adjustment.	Remove the EP-W cover, and inspect the gaps between the clutch rotor and armature, and the brake magnet and armature. The gaps should be no larger than .023" for EP-W-250's, and .037" for EP-W-400's. Adjust the gaps by axially moving the appropriate armature until the gap is correct. Once set, turn the clutch and brake power on and off to confirm that they engage, and rotate the input and output shafts to confirm that the friction surfaces do not drag when disengaged. Readjust if necessary.
Clutch or brake slips.	EP-W not properly sized for intended application	Review the Selection Information page of this instruction sheet to determine if the EP-W is properly sized for the application. For additional assistance, contact your Warner Electric distributor or Warner Electric Technical Support at 1-800-825-9050.
	Insufficient DC power supplied to clutch or brake coils.	Remove the EP-W cover, turn on the electrical power to the terminals, and check the voltage across each pair of terminals. The voltage at the terminals should be within 5% of the units rated voltage. If not, adjust or change the power supply to obtain the rated voltage.
	Incorrect coil resistance.	Remove the EP-W cover, disconnect the lead wires from the terminals on the clutch and brake coils, and measure the resistance of each coil with an appropriate ohmmeter. Both resistance measurements should be within 10% of the values listed in the Electrical Specifications of this instruction sheet. If not, replace the EP-W with a new unit.
	Clutch or brake friction faces contaminated.	Remove the EP-W cover and inspect the clutch and brake friction faces for contaminants. The friction surfaces should have a dry, polished appearance with some dust present. If they are wet or oily they can be carefully cleaned with a solvent, but optimum performance may never be achieved once the faces are contaminated. If slipping persists after cleaning, replace the EP-W with a new unit.

Clutch/Brake Selection Information

Horsepower vs. Shaft Speed

HP ▼	SHAFT SPEED AT CLUTCH (IN RPM)																				
	100	200	300	400	500	600	700	800	900	1000	1100	1200	1500	1800	2000	2400	3000	3600	4000	4500	5000
1/50																					
1/20																					
1/12																					
1/8																					
1/6																					
1/4																					
1/3																					
1/2																					
3/4																					
1																					
1-1/2																					
2																					
3																					

Selection Procedure

Determine the shaft speed at the Electro Pack location. The number listed at the intersection of horsepower and speed is the size Electro Pack you require.

Part Numbers

Model No.	Voltage DC	Part No.
EP-250	24	5130-273-060
	90	5130-273-061
EP-400	24	5131-273-030
	90	5131-273-031

Mechanical Specifications

Model Size	Voltage DC	Horsepower @ 1800 RPM	Static Torque lb. in.	Inertia-WR ² (lb-in ²)		Max. RPM	Weight lbs.
				Output	Input		
EP-250	24	1/2	70	.331	.293	7,500	7.1
	90						
EP-400	24	1	270	2.566	2.222	4,500	19.7
	90						

Electrical Coil Data

	EP-250-W Clutch/Brake		EP-400-W Clutch/Brake	
Voltage – DC	24	90	24	90
Resistance @ 20° C – Ohms	76.4	1079	73	1087
Current – Amperes	.314	.084	.332	.083
Watts	7.5	7.51	8.04	7.45
Coil Build up – milliseconds	48	44	154	154
Coil Decay – milliseconds	15	13	60	55

Build-up time equals current to approximately 90% of steady state value and flux to 90%. Decay time equals current to approximately 10% of steady state value and flux to 10%. Values are approximate because current changes lead or lag flux changes by a small amount.

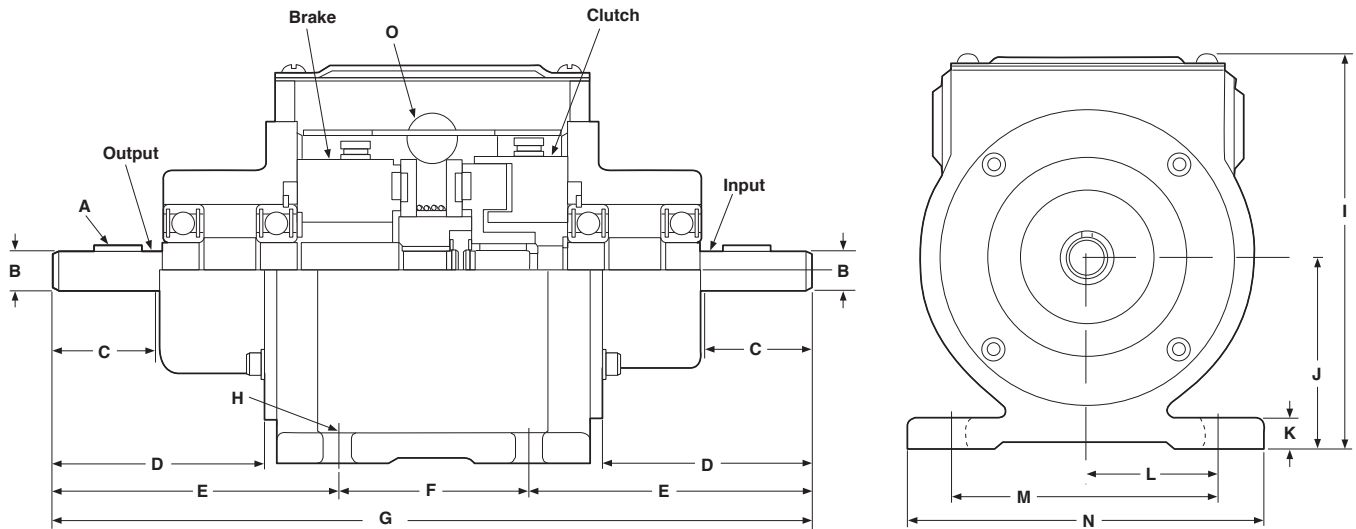

Dimensions

All dimensions are nominal, unless otherwise noted.

Size	A	B	C Min.	D	E	F	G Max.	H	I	J	K	L	M	N	O
250-W	1/8 x	.4995	1.250	2.468	3.312	2.250	8.968	.312 Wide (4 slots)	5.281	2.318 2.308	.375	1.625	3.250	4.250	1/2 - 14 NPT conduit x 2
	1/8 x	.4985													
	7/8	Dia.													
400-W	3/16 x	.7495	1.875	3.515	4.593	2.500	11.781	.312 Wide (4 slots)	6.937	3.474 3.464	.500	2.578	5.156	6.000	1/2 - 14 NPT conduit x 2
	3/16 x	.7485													
	1-3/8	Dia.													

Warranty

Warner Electric LLC warrants that it will repair or replace (whichever it deems advisable) any product manufactured and sold by it which proves to be defective in material or workmanship within a period of one (1) year from the date of original purchase for consumer, commercial or industrial use.

This warranty extends only to the original purchaser and is not transferable or assignable without Warner Electric LLC's prior consent.

Warranty service can be obtained in the U.S.A. by returning any defective product, transportation charges prepaid, to the appropriate Warner Electric LLC factory. Additional warranty information may be obtained by writing the Customer Satisfaction Department, Warner Electric LLC, 449 Gardner Street, South Beloit, Illinois 61080, or by calling 815-389-3771.

A purchase receipt or other proof of original purchase will be required before warranty service is rendered. If found defective under the terms of this warranty, repair or replacement will be made, without charge, together with a refund for transportation costs. If found not to be defective, you will be notified and, with your consent, the item will be repaired or replaced and returned to you at your expense.

This warranty covers normal use and does not cover damage or defect which results from alteration, accident, neglect, or improper installation, operation, or maintenance.

Some states do not allow limitation on how long an implied warranty lasts, so the above limitation may not apply to you.

Warner Electric LLC's obligation under this warranty is limited to the repair or replacement of the defective product and in no event shall Warner Electric LLC be liable for consequential, indirect, or incidental damages of any kind incurred by reason of the manufacture, sale or use of any defective product. Warner Electric LLC neither assumes nor authorizes any other person to give any other warranty or to assume any other obligation or liability on its behalf.

WITH RESPECT TO CONSUMER USE OF THE PRODUCT, ANY IMPLIED WARRANTIES WHICH THE CONSUMER MAY HAVE ARE LIMITED IN DURATION TO ONE YEAR FROM THE DATE OF ORIGINAL CONSUMER PURCHASE. WITH RESPECT TO COMMERCIAL AND INDUSTRIAL USES OF THE PRODUCT, THE FOREGOING WARRANTY IS IN LIEU OF AND EXCLUDES ALL OTHER WARRANTIES, WHETHER EXPRESSED OR IMPLIED BY OPERATION OF LAW OR OTHERWISE, INCLUDING, BUT NOT LIMITED TO, ANY IMPLIED WARRANTIES OF MERCHANTABILITY OR FITNESS.

Some states do not allow the exclusion or limitation of incidental or consequential damages, so the above limitation or exclusion may not apply to you. This warranty gives you specific legal rights and you may also have other rights which vary from state to state.

Changes in Dimensions and Specifications

All dimensions and specifications shown in Warner Electric catalogs are subject to change without notice. Weights do not include weight of boxing for shipment. Certified prints will be furnished without charge on request to Warner Electric.



Warner Electric LLC
31 Industrial Park Road • New Hartford, CT 06057
815-389-3771 • Fax: 815-389-2582
www.warnerelectric.com
An Altra Industrial Motion Company