

# Electro-Magnetic Single Disc Clutch and Brake Combination EM and EMER

Service Manual

P-2055-WE  
SM305gb - rev 11/04



 **Warner**<sup>®</sup>  
Electric

An Altra Industrial Motion Company

We, **WARNER ELECTRIC EUROPE**, 7, rue Champfleury, B.P. 20095, F-49182 St Barthélemy d'Anjou Cedex declare that the combined clutches and brakes are made in our factory from St Barthélemy d'Anjou,

and hereafter designated : **EM and EMER**

are exclusively designed for incorporation into a machine and to be assembled with other equipments to create a machine. The operation of the product is submitted to the conformity of the complete equipment, following the provisions of the machinery directive 89/392/EEC and if electric to the EMC directive 89/336 /EEC.

The conformity of the electric units to the Low Voltage directive 72/23 is supported by the full respect of the following standards : NFC 79300 and VDE 05808/8.65.

Drawn up in St Barthélemy d'Anjou, July 2002

E. PRAT, General Managing Director

## CONTENTS

1	Technical specifications	2	3.2	Handling	3
1.1	Description	2	3.3	Installing	3
1.2	Operation and principle	2	3.3.1	Installing interfaces	3
1.3	Basic data	2	3.3.2	Examples of typical assemblies	4
2	Precautions and restrictions on use	3	4	Electrical connection	4
2.1	Restrictions on use	3	4.1	Important recommendations	4
2.2	Precautions and safety measures	3	4.2	Power supply	4
3	Installation	3	5	Appendixes	5
3.1	Transport - storage	3	5.1	EM and EMER general configuration	5

## 1 Technical specifications

### 1.1 Description

Pre-assembled, combined assembly consisting of a clutch and an electromagnetic brake in a closed casing with modulable interfaces. An arrow on the casing shows the movement transmission direction. The start of the arrow shows the input which is on the clutch side. The end of the arrow shows the output which is on the brake side of the unit.

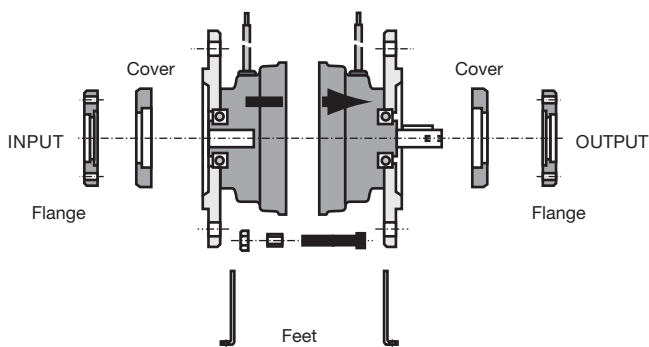

### 1.2 Operation and principle

**EM** and **EMER** clutches-brakes are mono friction disk and operate dry, they are activated or inactivated electromagnetically. The clutch and brake, in the **EM** type version, are engaged alternately whereas in the **EMER** type version, the clutch and brake are engaged simultaneously.

The **EMER** type describes the clutch-brake where the brake is electrically retained. When the **EMER**'s clutch and brake are no longer powered, the permanent magnet brake immobilizes movement and acts as a parking brake.

### 1.3 Basic data

		EM	ER	EM	ER	EM	ER	EM	ER	EM	ER
<b>Size</b>		2		3		4		5		6	
Transmissible Torque	Nm	7,5	4,5	15	9	25	14	50	28	130	76
Max. Speed	min <sup>-1</sup>	3600		3600		3600		3600		3600	
Weight	kg	2,9		4		7		11		23	
Outer ø	mm	112		142		180		200		240	
Height of shaft on foot	mm	63		71		90		100		132	



Symbol designating an action that might damage the brake



Symbol designating an action that might be dangerous to human safety



Symbol designating an electrical action that might be dangerous to human safety

## 2 Precautions and restrictions on use

### 2.1 Restrictions on use



This equipment is designed for dry running in an IP 64 envelope. Any link to a casing with oil bath must have non standard, reinforced strength seals.



Exceeding the maximum rotation speed stated in the basic data invalidates the warranty.



Clutch-brakes are normally fitted horizontally.



Clutch-brakes are supplied not burnished, they only transmit about 50% of nominal torque when new. The higher the speed and torque, the shorter the burnish in time. For critical applications (fast cycles, accurate stop-start), a phase must be provided to bed in the equipment and in this case a supply with overexcitation is particularly recommended.



The equipment is designed for an ambient temperature of 40° max. and has a 155°C insulation class.

### 2.2 Precautions in use and safety measures



This equipment is maintenance-free because an automatic wear compensator (autogap) is fitted. If it has to be opened, ensure that it is completely disconnected electrically and that there is no risk of accidental startup. All intervention have to be made by qualified personnel, owning this manual.



Any modification made to the brake without the express authorization of a representative of Warner Electric, in the same way than any use out of the contractual specifications accepted by “Warner Electric”, will result in the warranty being invalidated and Warner Electric will no longer be liable in any way with regard to conformity.

## 3 Installation

### 3.1 Transport / storage

Our pre-assembled equipment is supplied in individual packaging with a label stating the order configuration.

Our clutches are supplied in packaging guaranteeing a preservation period of 6 months with land or air transport, or after transport by ship to neighbouring continents (without crossing the tropics).

### 3.2 Handling



Never carry the equipment by its electricity supply cables or connectors.

### 3.3 Installing

#### 3.3.1 Installing interfaces

The interfaces for our equipment are in compliance with European standards for motor clamps, shaft ends and keying. After identifying the input and output, the clutch-brake can be assembled with the corresponding interfaces. There is no work or adjustment to be performed on assembly with our automatic wear compensation system.



There must be no impacts along the shafts that could be sufficiently excessive to affect the adjustment position of armatures fitted to the autogap system.

If one of the armatures is unable to come into contact with its friction lining because it is too distant or blocked, it is however possible to apply to the terminals of the corresponding coil, an excess voltage from 20 to 50% of the nominal value for a few seconds so as to put it back in the right place.



The link clamp flanges and closure cover are modulable interfaces. The clutch module or that for the brake with a male shaft, **VAR 01/02/04**, can only be associated with a cover or flange of **M1** male centering type. The clutch module or that for the brake with a hollow shaft **VAR 02/03/04** can only be associated with **M2** or **M3** female centering type flanges. The **M2** type flange adapts with the **B5** and **B35** motor clamp and the **M3** type flange with the **B14** and **B34** motor clamp.

### 3.3.2 Examples of typical assemblies

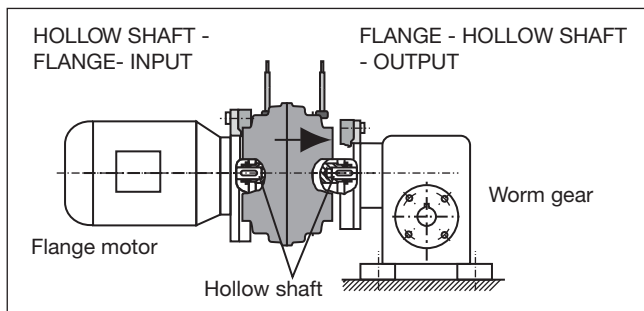
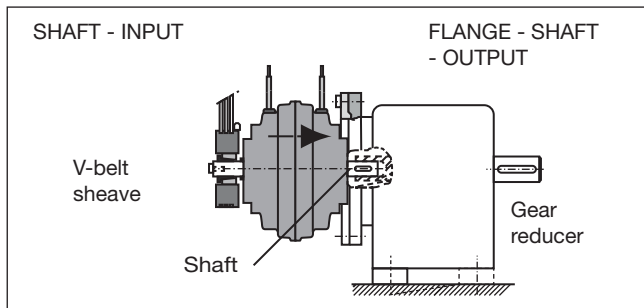
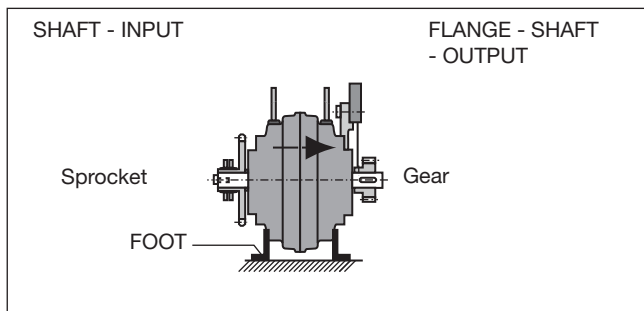

## 4 Electrical connection

**EM** and **EMER** should be supplied with direct current and are fitted clutch side and brake side with a 900 mm long cable or a connector to supply them independently.

 The polarity has no major effect on the operation of the **EM** version, as opposed to the **EMER** version for which the polarity marked must be scrupulously complied with on the **EMER** brake.

Also, when fast, accurate cycling is required, one seeks to avoid any residual torque being generated by residual magnetic currents from the clutch and brake that influence the armature's separation time.

For this, the coils must be correctly polarised and we recommend that the clutch's brown or red wire and the brake's blue or black wire are connected to the electric potential.

For equipment with a terminal block, tab 1 is connected to the brown wire and tab 2 is connected to the blue wire.

## 4.1 Important recommendations

 All works on the electrical connections have to be made with power off.

 Be sure to comply with the nominal supply voltage. Low supply level results in a reduction of start distance and transmissible torque.

The connecting wires should be of sufficient cross section to avoid drops in the voltage between the supply and the equipment being supplied.

I (A) / L (m)	0 to 10 m	from 10 to 20 m
0 to 3 (A)	1,5 mm <sup>2</sup>	1,5 mm <sup>2</sup>
3 to 6 (A)	1,5 mm <sup>2</sup>	2,5 mm <sup>2</sup>

Tolerance for supply voltage to the clutch and brake terminals + 5% - 10% (NF C 79-300).

## 4.2 Supply, cabling

To control our clutch-brakes, **Warner Electric** advises that you use one of its control units. Different models, suited to each application, are available:

- **CBC 400/450** is the most basic, enabling the clutch and brake to be engaged alternatively or simultaneously, but without adjustment of the voltage being possible.
- **CBC 500/550** enables the clutch-brake to be engaged alternatively or simultaneously and the voltage is adjustable. It is especially suited to **EMERs** where voltage adjustment is necessary on the electro-retained brake.
- **CBC 700** is a control unit with overexcitation which enables a very fast rise in torque, it is especially suited to fast cycles and very accurate stops.
- **CBC 750** is a control unit with very high overexcitation. It is exclusively for similar but more severe applications than **CBC 700**.

Warner Electric control units provide protection for coils and circuits, as well as anti-overlapping. In the event of our clutch-brakes being used without one of our control units, with DC circuit switching, it is essential that the coil is protected against excessive voltage by a varistor fitted in parallel.

## 5 Appendixes

### 5.1 EM and EMER general configuration

- Voltage: 24/90 VDC (EMER at 24 VDC only)
- With feet / without foot
- Male / hollow input shaft
- Male / hollow output shaft
- Supply by cables / connectors
- Male shaft on input or output with M1 cover / flange
- Hollow shaft on input or output with M2 flange / M1 flange

<b>Size</b>	<b>Shaft</b>	<b>Flange M1</b>	<b>Flange M2</b>	<b>Flange M3</b>
<b>2</b>	11 / 14	F115 / F130	F115 / F130	F75 / F85
<b>3</b>	14 / 19	F115 / F130 / F165	F115 / F130 / F165	F75 / F85 / F100
<b>4</b>	19 / 24	F130 / F165	F130 / F165	F100 / F115 / F130
<b>5</b>	24 / 28	F130 / F165 / F215	F165 / F215	F115 / F130
<b>6</b>	28 / 38	F215 / F265	F215 / F265	F165 / F215

# Warranty

Warner Electric LLC warrants that it will repair or replace (whichever it deems advisable) any product manufactured and sold by it which proves to be defective in material or workmanship within a period of one (1) year from the date of original purchase for consumer, commercial or industrial use.

This warranty extends only to the original purchaser and is not transferable or assignable without Warner Electric LLC's prior consent.

Warranty service can be obtained in the U.S.A. by returning any defective product, transportation charges prepaid, to the appropriate Warner Electric LLC factory. Additional warranty information may be obtained by writing the Customer Satisfaction Department, Warner Electric LLC, 449 Gardner Street, South Beloit, Illinois 61080, or by calling 815-389-3771.

A purchase receipt or other proof of original purchase will be required before warranty service is rendered. If found defective under the terms of this warranty, repair or replacement will be made, without charge, together with a refund for transportation costs. If found not to be defective, you will be notified and, with your consent, the item will be repaired or replaced and returned to you at your expense.

This warranty covers normal use and does not cover damage or defect which results from alteration, accident, neglect, or improper installation, operation, or maintenance.

Some states do not allow limitation on how long an implied warranty lasts, so the above limitation may not apply to you.

Warner Electric LLC's obligation under this warranty is limited to the repair or replacement of the defective product and in no event shall Warner Electric LLC be liable for consequential, indirect, or incidental damages of any kind incurred by reason of the manufacture, sale or use of any defective product. Warner Electric LLC neither assumes nor authorizes any other person to give any other warranty or to assume any other obligation or liability on its behalf.

WITH RESPECT TO CONSUMER USE OF THE PRODUCT, ANY IMPLIED WARRANTIES WHICH THE CONSUMER MAY HAVE ARE LIMITED IN DURATION TO ONE YEAR FROM THE DATE OF ORIGINAL CONSUMER PURCHASE. WITH RESPECT TO COMMERCIAL AND INDUSTRIAL USES OF THE PRODUCT, THE FOREGOING WARRANTY IS IN LIEU OF AND EXCLUDES ALL OTHER WARRANTIES, WHETHER EXPRESSED OR IMPLIED BY OPERATION OF LAW OR OTHERWISE, INCLUDING, BUT NOT LIMITED TO, ANY IMPLIED WARRANTIES OF MERCHANTABILITY OR FITNESS.

Some states do not allow the exclusion or limitation of incidental or consequential damages, so the above limitation or exclusion may not apply to you. This warranty gives you specific legal rights and you may also have other rights which vary from state to state.

## Changes in Dimensions and Specifications

All dimensions and specifications shown in Warner Electric catalogs are subject to change without notice. Weights do not include weight of boxing for shipment. Certified prints will be furnished without charge on request to Warner Electric.



**Warner Electric Europe**  
7 rue Champfleury, B.P. 20095, St Barthelemy d'Anjou - France  
+33 (0)2 41 21 24 24 • Fax: +33 (0)2 41 21 24 70  
[www.warnerelectric.com](http://www.warnerelectric.com)