

# Primary Brake Spline Drive Armature PB-825, PB-1000, PB-1225, PB-1525

Installation Instructions

P-209-WE  
819-0517



## Contents

Installation Instructions	
PB-825 PB-1000 PB-1225 PB-1525	3
Coil Data	5
Burnishing and Maintenance	6
Illustration Drawings	
PB-825	8
PB-1000	10
PB-1225	12
PB-1525	14
Bushings	16
Warranty	Back Cover

**⚠ WARNING** Follow the installation instructions in this manual carefully to ensure safe, reliable operation. All stated or implied manufacturer warranties are voided if this product is not installed in accordance with these instructions.

**⚠ WARNING** Failure to follow these instructions may result in product damage, equipment damage, and serious or fatal injury to personnel.



**PB-825**



**PB-1225**

# Primary Brake Heavy Duty Spline Drive Armature

## PB-825 PB-1000 PB-1225 PB-1525

The illustration drawings, parts lists, and exploded views for these units can be found beginning on page 8.

### A. Installing the Conduit Box

Install the conduit box on the magnet. Instructions for this procedure can be found with conduit box.

### B. Mounting the Magnet

The brake magnet is mounted to a stationary machine member by a flange. Extreme care must be taken in selecting the location for the mounting of the magnet. Proper positioning is very important for the unit to function correctly.

1. A pilot diameter on the mounting surface is essential to hold the magnet within the required tolerances. (See Figure 1.)

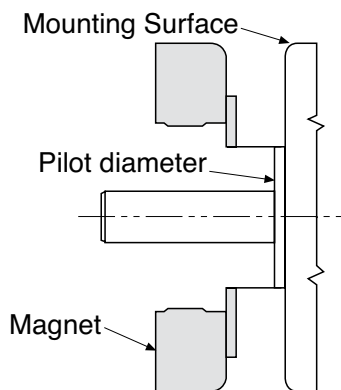

Figure 1

2. A machined pilot diameter is provided on the magnet mounting flange (refer to illustration drawings on page 8, 10, 12, or 14) to aid in the proper positioning of the magnet.

3. Once the mounting surface has been prepared, the magnet is bolted in place with capscrews and lockwashers. (See Figure 2.)

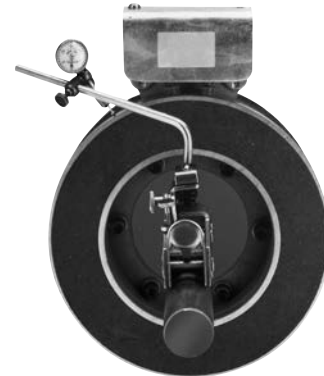

Figure 2

4. Use a dial indicator to check the unit for concentricity and squareness to the shaft. The unit should be concentric within .010 T.I.R. and square within .006 T.I.R. (See Figure 3.)



Figure 3

### C. Assembling the Armature and Hub

The heavy duty units contain spline drive armatures and hubs. The armatures are shipped with a built-in autogap spring accessory. This device automatically maintains a gap of about 1/32-inch between the armature and magnet faces for the life of the unit.

These units are shipped with the armature, splined armature adapter, and autogap already assembled. The splined hub, retainer ring, and bushing are shipped as separate parts.

Follow these instructions to assemble the armature and splined hub:

**Step 1** Place the armature-splined adapter assembly on a flat surface with the segmented side up.

**Step 2** Push the splined hub, with the retainer ring groove down, through the autogap spring and splined armature adapter. (See Figure 4.)

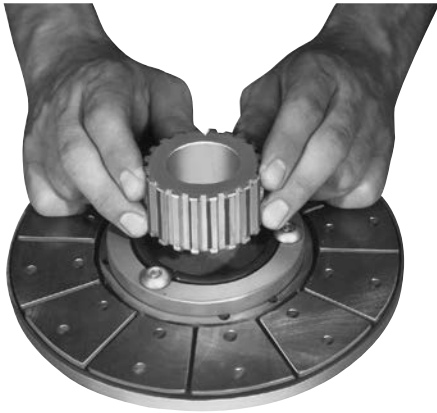

**Figure 4**

**Step 3** Turn the armature-adapter assembly over, and insert the retainer ring in the groove. (See Figure 5.)



**Figure 5**

**Step 4** Slide the armature-adapter assembly up against the retainer ring.

**Step 5** Insert the bushing into the retainer ring side of the splined hub. The clearance holes in the bushing flange should line up with the tapped holes in the splined hub. (See Figure 6.)



**Figure 6**

#### **D. Mounting the Armature and Hub Assembly**

1. Slide the complete armature and hub assembly onto the shaft until the armature face touches the magnet face. (See Figure 7.)



**Figure 7**

2. Tighten the bushing capscrews, taking a few turns at a time on each capscrew. As the capscrews are tightened, the armature will back away slightly from the magnet. There should be a clearance of 1/16" between the armature and magnet when the capscrews are completely tight. (See Figure 8.)
3. When the bushing is secure on the shaft, push the armature against the magnet face. When the armature is released, it will spring back about 1/32". The gap will be automatically maintained for the life of the unit. (See Figures 9 & 10.)

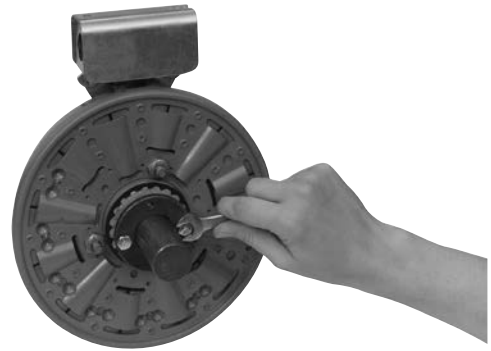

**Figure 8**



**Figure 9**

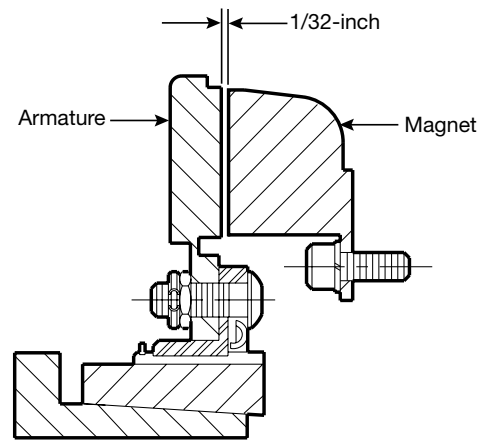

**Figure 10**

## Coil Data

Unit Size	PB-825			PB-1000			PB-1225			PB-1525		
Voltage — DC	6	24	90	6	24	90	6	24	90	6	24	90
Resistance @ 20°C — Ohms	1.27	20.4	223.3	1.23	19.7	248.7	1.33	22.3	261.7	1.45	19.8	258.4
Current — Amperes	4.74	1.18	.4	4.87	1.22	.36	4.5	1.08	.34	4.13	1.21	.35
Watts	28	28	36	29	29	33	27	26	31	25	29	31
Coil Build-up — Milliseconds	170	170	170	205	220	235	300	320	350	470	490	512
Coil Decay — Milliseconds	70	75	80	70	75	80	190	190	190	200	170	140

## Burnishing and Maintenance

### Burnishing

Intimate metal to metal contact is essential between the armature and the metal rings (poles) of the magnet or rotor. Warner Electric clutches and brakes leave the factory with the friction material slightly undercut to assure good initial contact.

Normally, the desired wearing-in process occurs naturally as the surfaces slip upon engagement. The time for wear-in, which is necessary to obtain the ultimate torque of the unit, will vary depending on speed, load, or cycle duty.

If maximum torque is required immediately after installation, the unit should be burnished by slipping the friction surfaces together at reduced voltage. It is recommended that the burnishings be done right on the application, if at all possible.

Burnishing at high speed will result in a smoother wear-in pattern and reduce the time for burnishing. The voltage should be set at approximately 30% or 40% of the rated value.

The unit should be cycled on and off to allow sufficient time between slip cycles to prevent overheating.

When a Warner Electric brake or clutch is properly assembled and installed, no further servicing, lubrication, or maintenance should be required throughout the life of the unit.

### Maintenance

**Wear Pattern:** Wear grooves appear on the armature and magnet surfaces. This is a normal wear condition, and does not impair functioning of the unit. Normally, the magnet and armature, as a mating pair, will wear at the same rate. It is the usual recommendation that both components be replaced at the same time.

Remachining the face of a worn armature is not recommended. If a replacement armature is to be used with a used magnet, it is necessary to remachine the worn magnet face. In refacing a

magnet: (1) machine only enough material to clean up the complete face of the magnet; (2) hold the face within .005" of parallel with the mounting plate; and (3) undercut the molded facing material .002" - .004" below the metal poles.

**Heat:** Excessive heat and high operating temperatures are causes of rapid wear. Units, therefore, should be ventilated as efficiently as possible, especially if the application requires fast, repetitive cycle operation.

**Foreign Materials:** If units are used on machinery where fine, abrasive dust, chips or grit are dispelled into the atmosphere, shielding of the brake may be necessary if maximum life is to be obtained.

Where units are used near gear boxes or transmissions requiring frequent lubrication, means should be provided to protect the friction surfaces from oil and grease to prevent serious loss of torque.

Oil and grease accidentally reaching the friction surfaces may be removed by wiping with a rag dampened with a suitable cleaner, which leaves no residue. In performing this operation, do not drench the friction material.

If the friction materials have been saturated with oil or grease, no amount of cleaning will be completely effective. Once such a unit has been placed back in service, heat will cause the oil to boil to the surface, resulting in further torque loss.

**Torque Loss:** If a brake or clutch slips or loses torque completely, the initial check should be the input voltage to the magnet as follows:

**90-Volt Series:** Connect a DC voltmeter with a range of 0-100 or more directly across the magnet terminals. With the power on and the potentiometer turned up, a normal reading is 90 volts, although 85 to 95 is satisfactory. The reading should drop as the potentiometer control is adjusted counterclockwise.

**24-Volt Series:** Use a DC voltmeter with a range of 0-30 volts or more. A normal reading is approximately 22-26 volts.

**6-Volt Series:** Use a DC voltmeter of approximately 0-15 volt range. A normal reading is from 5.5 to 6.5 volts.

The above checks normally are sufficient. Further checks may be made as follows: a low range ammeter, when connected in series with one magnet lead, will normally indicate approximately .40 amperes for the 90 volt units, 1.0 ampere for the 24 volt, and 3.5 amperes for the 6 volt series. These readings are with the power on and the potentiometer control in the maximum position.

Ohmmeter checks should be made with the power off and the circuit open (to be certain, disconnect one lead to the magnet). Average resistance for the 90 volt series is 220 ohms; for the 24 volt, 20 ohms; and for the 6 volt series, 1.5 ohms. A very high or infinite resistance reading would indicate an open coil.

If the above checks indicate that the proper voltage and current is being supplied to the magnet, mechanical parts should be checked to assure that they are in good operating condition and properly installed.

# PB-825 Brake-Heavy Duty

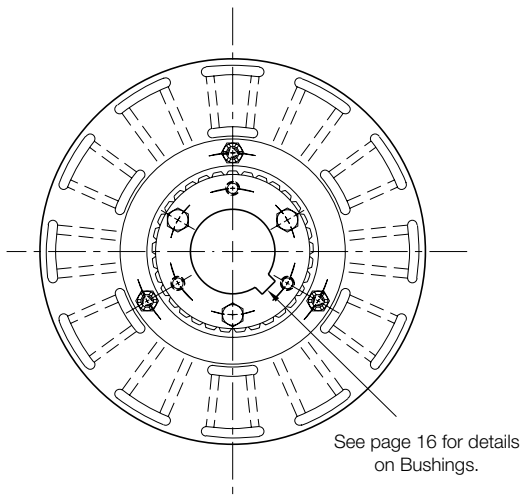

**Armature View**

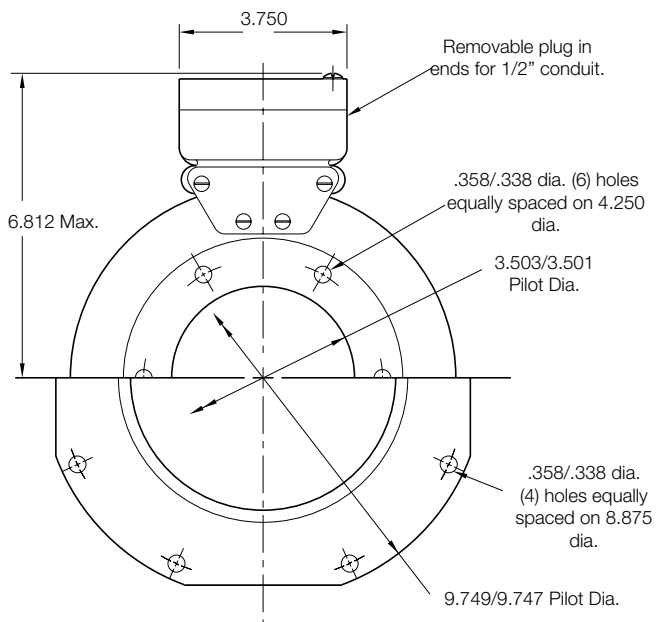

**Magnet View  
(Inside & Outside Mounted)**

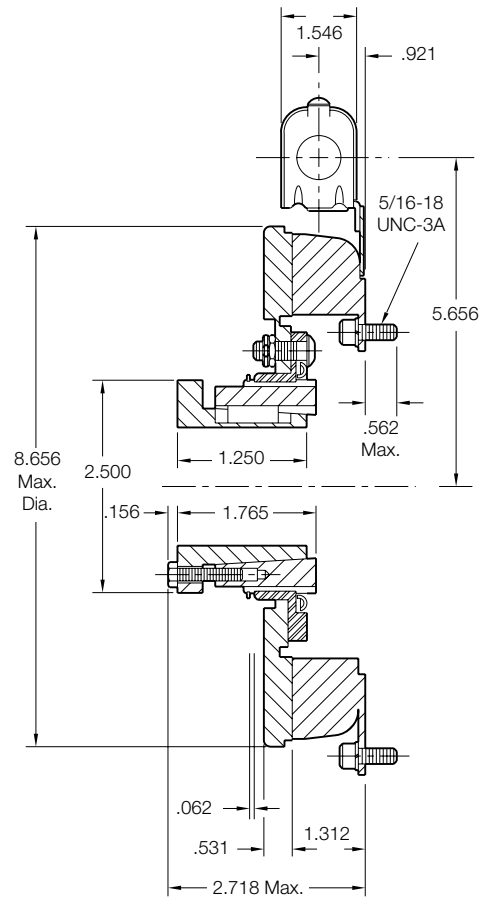

Shaft Size	.500 – 1.500
Static Torque	125 lb. ft.
Maximum Speed	4,000 rpm
Standard Voltage	D.C. 6, 24, 90

\* Mounting holes are within .010 of true position relative to pilot diameter.

## Customer Shall Maintain:

1. Squareness of magnet mounting face with armature shaft within .006 T.I.R.
2. Concentricity of magnet mounting pilot diameter with armature shaft within .010 T.I.R.





# PB-825 Brake-Heavy Duty

# Drawing I-25567

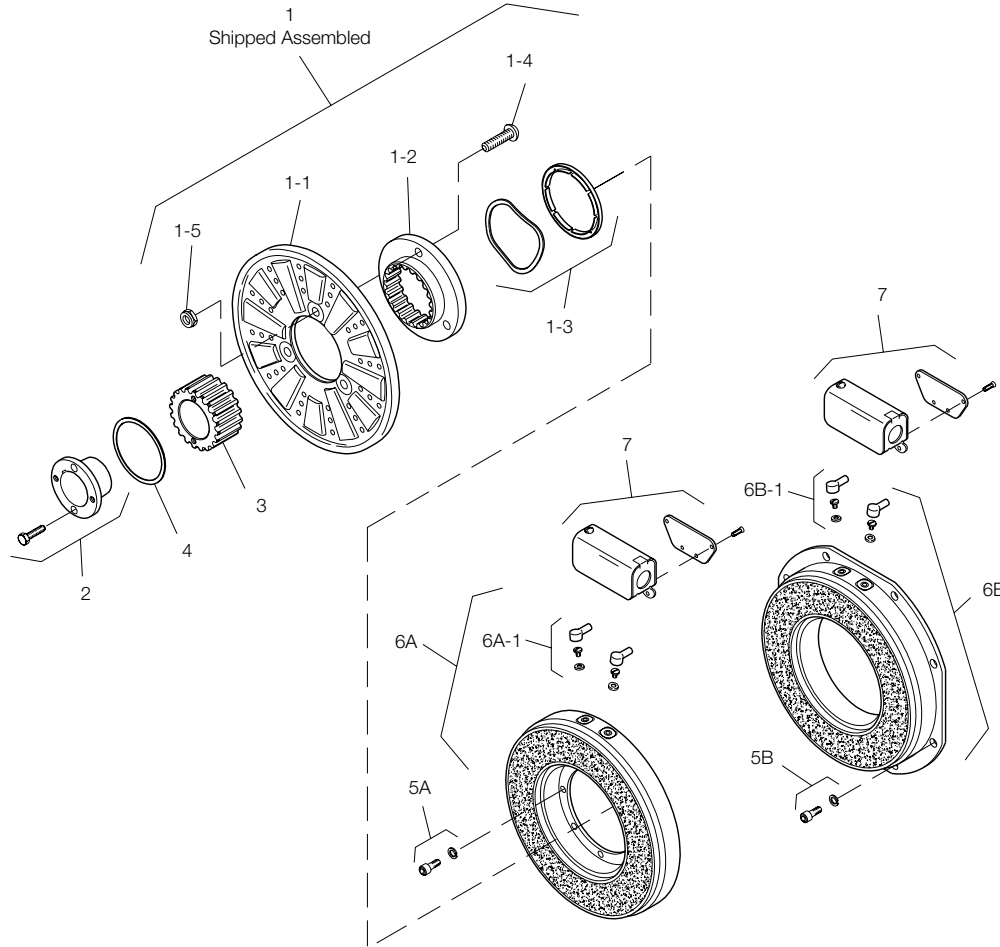

Item	Description	PB-825, H.D. Part Number	Qty.
1	Armature Assembly	5321-111-001	1
1-1	Armature	5321-111-022	1
1-2	Splined Adapter	104-0008	1
1-3	Autogap Accessory	5321-101-006	1
1-4	Screw	797-0272	3
1-5	Locknut	661-0004	3
2	Bushing		
	1/2" to 1-1/2" Bore	180-0002 to 180-0018*	1
	3/4" to 2-11/16" Bore		
3	Splined Hub	540-0057	1
4	Retainer Ring	748-0006	1
5A	Mounting Accessory - I.M.	5321-101-001	1
5B	Mounting Accessory - O.M.	5321-101-002	1
6A	Magnet - Inside Mounted		1
	6 Volt	5311-631-002	
	24 Volt	5311-631-003	
	90 Volt	5311-631-004	
	†90 Volt LK Facing	5311-631-011	
6A-1	Terminal Accessory	5311-101-001	1
6B	Magnet - Outside Mounted		1
	6 Volt	5311-631-007	
	24 Volt	5311-631-009	
	90 Volt	5311-631-008	
	†90 Volt LK Facing	5311-631-012	

Item	Description	PB-825, H.D. Part Number	Qty.
6B-1	Terminal Accessory	5311-101-001	1
7	Conduit Box	5200-101-011	1

\*See page 16 for specific part numbers. †Optional LK facing available.

## How to Order:

1. Specify Bore Size for Item 2.
2. Specify Inside Mounted for Items 5A and 6A or Outside Mounted for Items 5B and 6B.
3. Specify Voltage for Item 6A or 6B.
4. See P-1264-WE for Power Supplies.

## Example:

PB-825 Brake per I-25567 - 90 Volt, 1" Bore, Inside Mounted

These units, when used in conjunction with the correct Warner Electric conduit box, meet the standards of UL508 and are listed under guide card #NMTR, file #59164. These units are CSA certified under file #LR11543.

# PB-1000 Brake-Heavy Duty

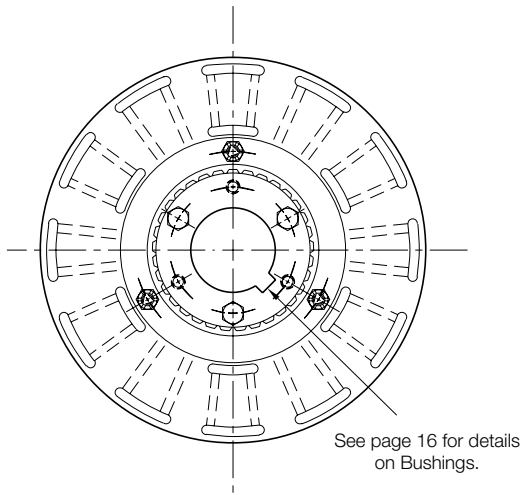

**Armature View**

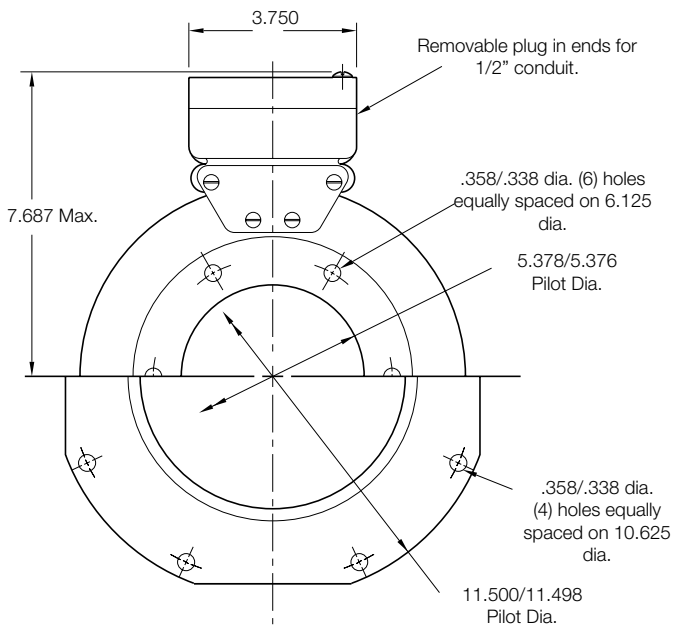

**Magnet View  
(Inside & Outside Mounted)**

\* Mounting holes are within .010 of true position relative to pilot diameter.

## Customer Shall Maintain:

1. Squareness of magnet mounting face with armature shaft within .006 T.I.R.
2. Concentricity of magnet mounting pilot diameter with armature shaft within .010 T.I.R.

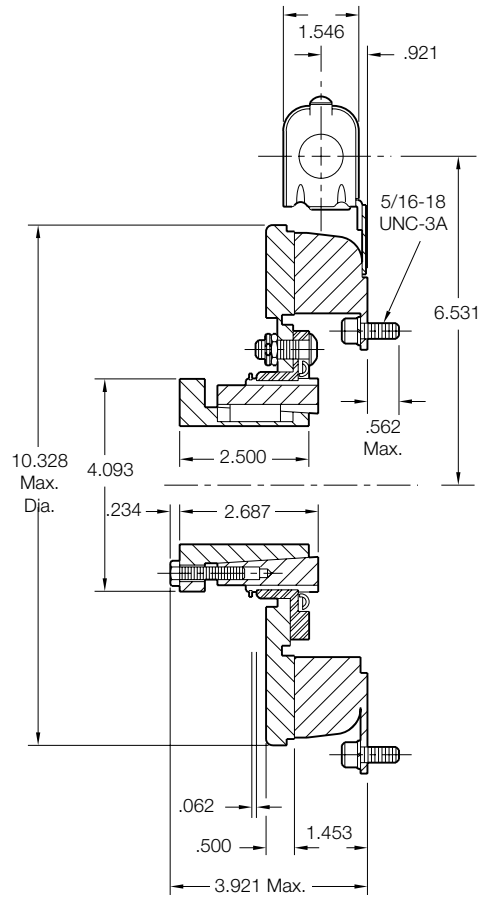

Shaft Size	.750 – 2.687
Static Torque	240 lb. ft.
Maximum Speed	3,600 rpm
Standard Voltage	D.C. 6, 24, 90

# PB-1000 Brake—Heavy Duty

# Drawing I-25587

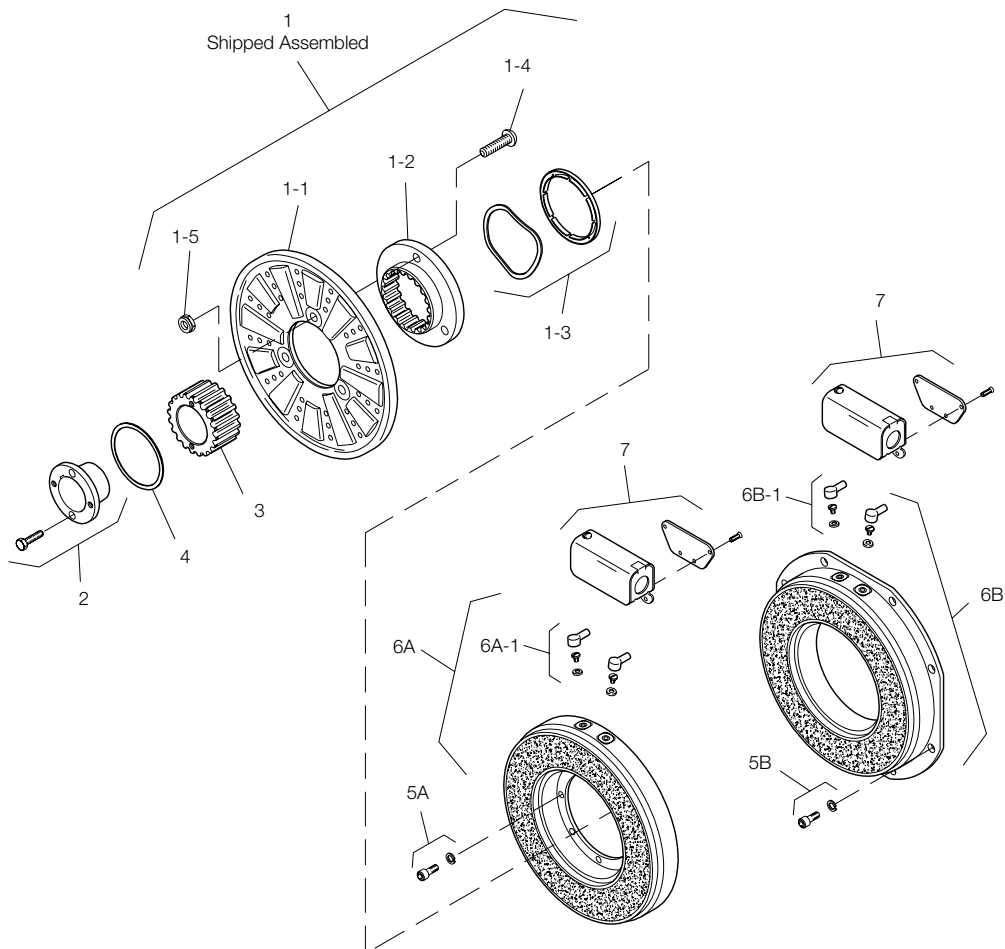

Item	Description	PB-1000, H.D. Part Number	Qty.
1	Armature Assembly	5322-111-002	1
1-1	Armature	5322-111-036	1
1-2	Splined Adapter	104-0009	1
1-3	Autogap Accessory	5322-101-004	1
1-4	Screw	797-0272	3
1-5	Locknut	661-0004	3
2	Bushing		
	1/2" to 1-1/2" Bore		
	3/4" to 2-11/16" Bore	180-0026 to 180-0056*	1
3	Splined Hub	540-0062	1
4	Retainer Ring	748-0007	1
5A	Mounting Accessory - I.M.	5321-101-001	1
5B	Mounting Accessory - O.M.	5321-101-002	1
6A	Magnet - Inside Mounted		1
	6 Volt	5312-631-004	
	24 Volt	5312-631-005	
	90 Volt	5312-631-006	
	†90 Volt LK Facing	5312-631-001	
6A-1	Terminal Accessory	5311-101-001	1
6B	Magnet - Outside Mounted		1
	6 Volt	5312-631-011	
	24 Volt	5312-631-013	
	90 Volt	5312-631-012	
	†90 Volt LK Facing	5312-631-002	

Item	Description	PB-1000, H.D. Part Number	Qty.
6B-1	Terminal Accessory	5311-101-001	1
7	Conduit Box	5200-101-011	1

\*See page 16 for specific part numbers. †Optional LK facing available.

## How to Order:

1. Specify Bore Size for Item 2.
2. Specify Inside Mounted for Items 5A and 6A or Outside Mounted for Items 5B and 6B.
3. Specify Voltage for Item 6A or 6B.
4. See P-1264-WE for Power Supplies.

## Example:

PB-1000 Brake per I-25587 - 90 Volt, 1-1/2" Bore, Inside Mounted

These units, when used in conjunction with the correct Warner Electric conduit box, meet the standards of UL508 and are listed under guide card #NMTR, file #59164. These units are CSA certified under file #LR11543.

# PB-1225 Brake-Heavy Duty

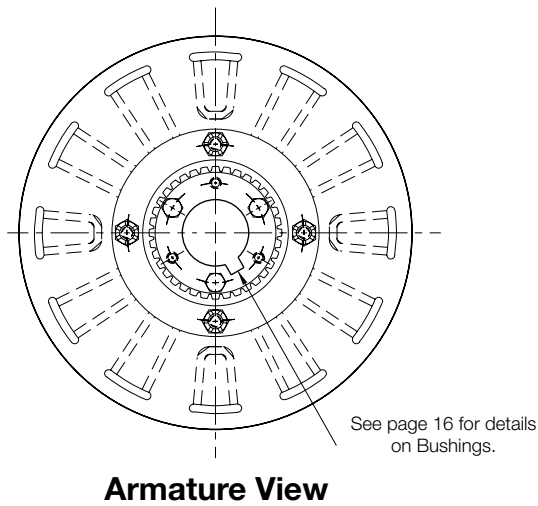

**Armature View**

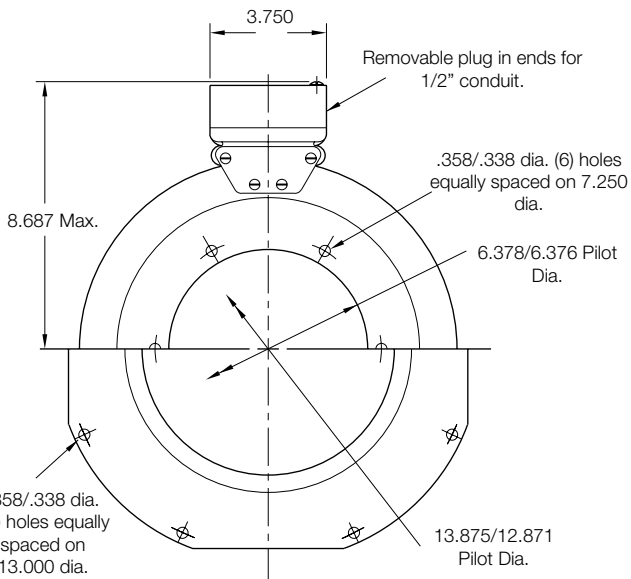
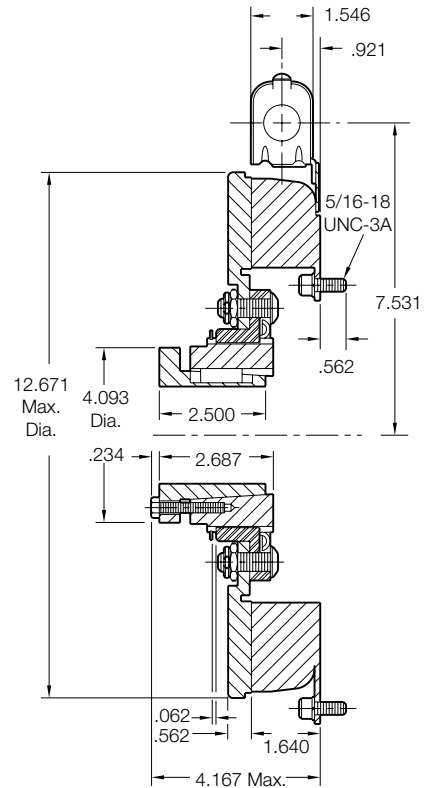

**Magnet View**

Shaft Size	.750 – 2.687
Static Torque	465 lb. ft.
Maximum Speed	3,000 rpm
Standard Voltage	D.C. 6, 24, 90

\* Mounting holes are within .010 of true position relative to pilot diameter.

## Customer Shall Maintain:

1. Squareness of magnet mounting face with armature shaft within .006 T.I.R.
2. Concentricity of magnet mounting pilot diameter with armature shaft within .010 T.I.R.



# PB-1225 Brake-Heavy Duty

# Drawing I-25607

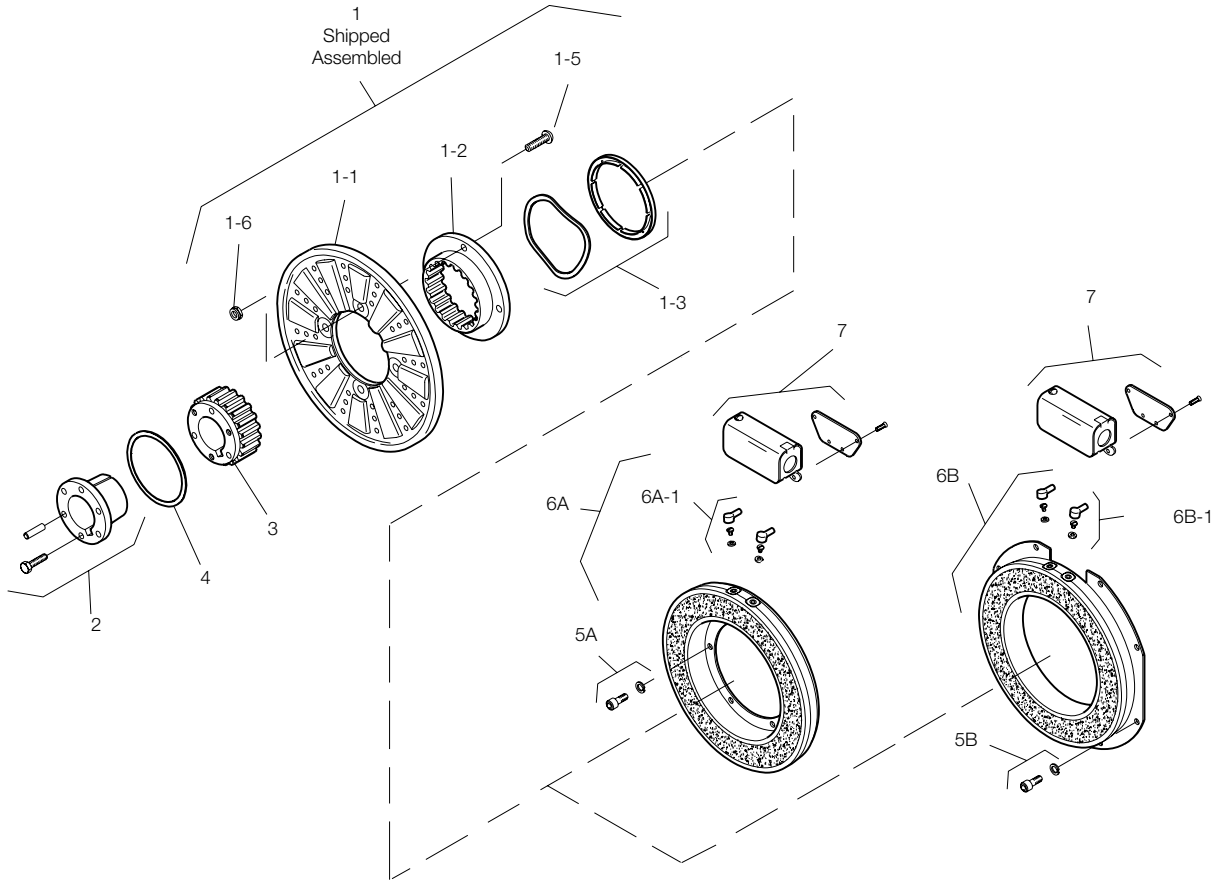

Item	Description	PB-1225, H.D. Part Number	Qty.
1	Armature & Splined Adapter	5323-111-001	1
1-1	Armature	5323-111-034	1
1-2	Splined Adapter	104-0010	1
1-3	Autogap Accessory	5323-101-002	1
1-4	Retainer Plate		
1-5	Screw	797-0281	4
1-6	Locknut	661-0005	4
2	Bushing		
	3/4" to 2-5/8" Bore	180-0226 to 180-0057*	1
3	Splined Hub	540-0064	1
4	Retainer Ring	748-0005	1
5A	Mounting Accessory - I.M.	5321-101-001	1
5B	Mounting Accessory - O.M.	5321-101-002	2
6A	Magnet - Inside Mounted		1
	6 Volt	5313-631-005	
	24 Volt	5313-631-006	
	90 Volt	5313-631-007	
	†90 Volt	5313-631-001	
6A-1	Terminal Accessory	5311-101-001	1
6B	Magnet - Outside Mounted		1
	6 Volt	5313-631-010	
	24 Volt	5313-631-012	
	90 Volt	5313-631-011	
	†90 Volt	5313-631-002	

Item	Description	PB-1225, H.D. Part Number	Qty.
6B-1	Terminal Accessory	5311-101-001	1
7	Conduit Box	5200-101-011	1

\*See page 16 for specific part numbers. †Optional LK facing available.

## How to Order:

1. Specify Bore Size for Item 2.
2. Specify Inside Mounted for Items 5A and 6A or Outside Mounted for Items 5B and 6B.
3. Specify Voltage for Item 6A or 6B.
4. See P-1264-WE for Power Supplies.

## Example:

PB-1225 Clutch per I-25607 - 90 Volt, 1-1/2" Bore, Inside Mounted

These units, when used in conjunction with the correct Warner Electric conduit box, meet the standards of UL508 and are listed under guide card #NMTR, file #59164. These units are CSA certified under file #LR11543.

# PB-1525 Brake-Heavy Duty

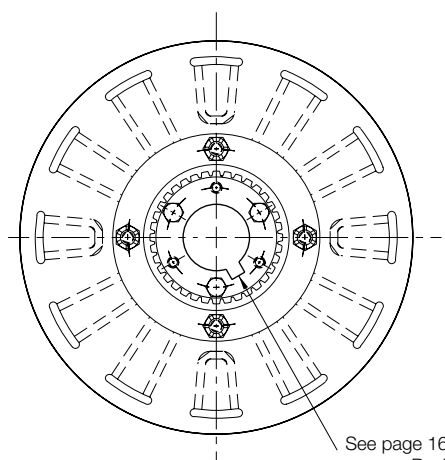

**Armature View**

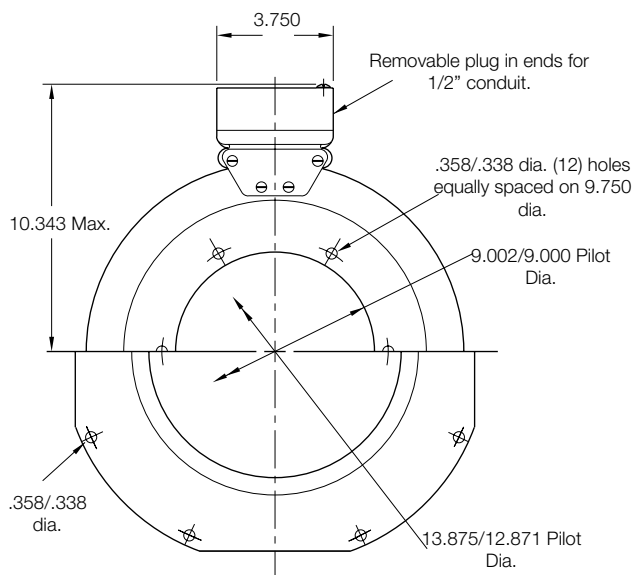
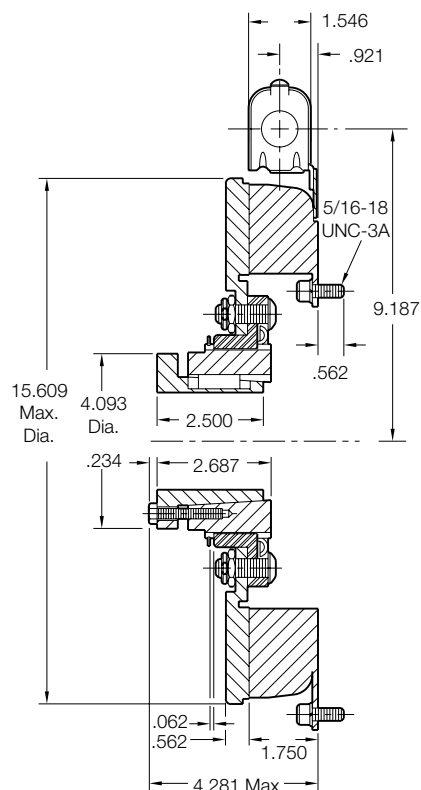

**Magnet View**

Shaft Size	.750 – 2.687
Static Torque	700 lb. ft.
Maximum Speed	2,000 rpm
Standard Voltage	D.C. 6, 24, 90

\* Mounting holes are within .010 of true position relative to pilot diameter.

## Customer Shall Maintain:

1. Squareness of magnet mounting face with armature shaft within .006 T.I.R.
2. Concentricity of magnet mounting pilot diameter with armature shaft within .010 T.I.R.



# PB-1525 Brake-Heavy Duty

# Drawing I-25634

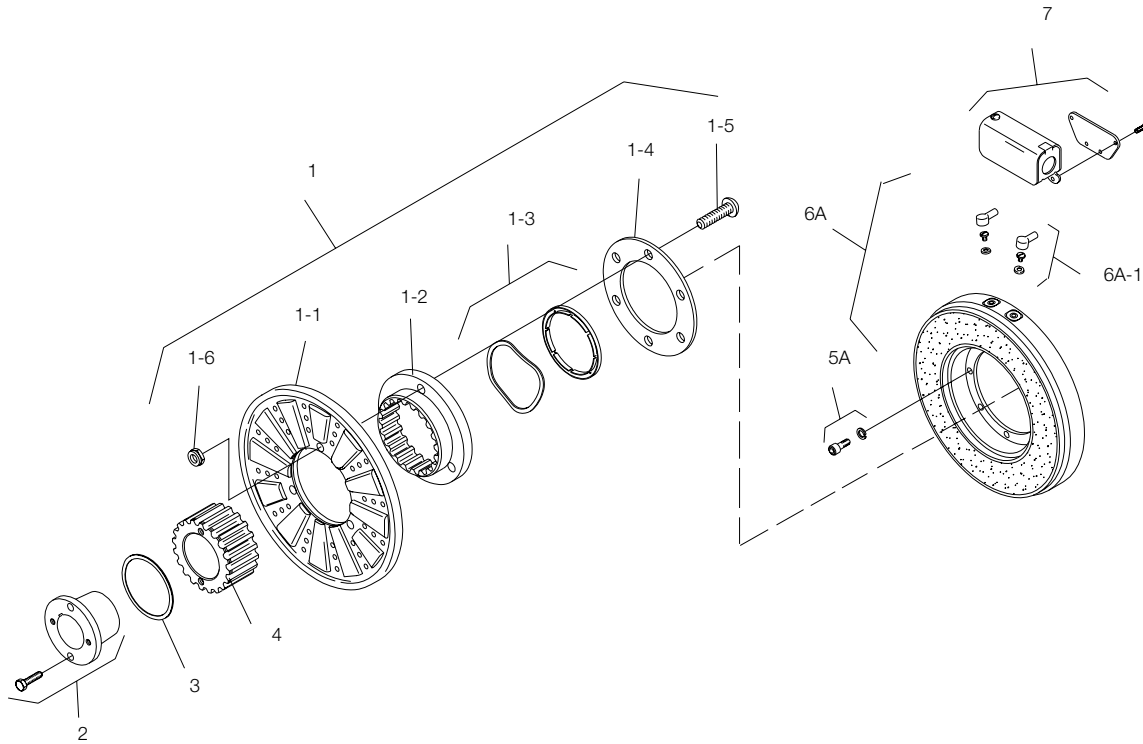

Item	Description	PB-1525, H.D. Part Number	Qty.
1	Armature & Splined Adapter	5324-111-001	1
1-1	Armature	5324-111-034	1
1-2	Splined Adapter	104-0011	1
1-3	Autogap Accessory	5323-101-002	1
1-4	Retainer Plate	686-0003	1
1-5	Screw	797-0272	8
1-6	Locknut	661-0004	8
2	Bushing		
	3/4" to 2-5/8" Bore	180-0026 to 180-0057*	1
3	Splined Hub	540-0064	1
4	Retainer Ring	748-0005	1
5A	Mounting Accessory - I.M.	5321-101-001	2
5B	Mounting Accessory - O.M.		
6A	Magnet - Inside Mounted		1
	6 Volt	5314-631-004	
	24 Volt	5314-631-006	
	90 Volt	5314-631-005	
	†90 Volt	5314-631-001	
6A-1	Terminal Accessory	5311-101-001	1
6B	Magnet - Outside Mounted		
6B-1	Terminal Accessory		
7	Conduit Box	5200-101-011	1

\*See page 16 for specific part numbers. †Optional LK facing available.

## How to Order:

1. Specify Bore Size for Item 2.
2. Specify Inside Mounted for Items 5A and 6A or Outside Mounted for Items 5B and 6B.
3. Specify Voltage for Item 6A or 6B.
4. See P-1264-WE for Power Supplies.

## Example:

PB-1525 Clutch per I-25634 - 90 Volt, 1-3/4" Bore

These units, when used in conjunction with the correct Warner Electric conduit box, meet the standards of UL508 and are listed under guide card #NMTR, file #59164. These units are CSA certified under file #LR11543.

# Bushing Part Numbers

## Browning Bushing

Shaft Size	Keyway Size	Bushing Number		
		Warner Electric	Browning	
1/2	1/8 x 1/16	180-0002	H-1	
9/16	1/8 x 1/6	180-0003		
5/8	3/16 x 3/32	180-0004		
11/16	3/16 x 3/32	180-0005		
3/4	3/16 x 3/32	180-0006		
13/16	3/16 x 3/32	180-0007		
7/8	3/16 x 3/32	180-0008		
15/16	1/4 x 1/8	180-0009		
1	1/4 x 1/8	180-0010		
1-1/6	1/4 x 1/8	180-0011		
1-1/8	1/4 x 1/8	180-0012		
1-3/16	1/4 x 1/8	180-0013		
1-1/4	1/4 x 3/16	180-0014		
1-5/16	5/16 x 7/32	180-0015		
1-3/8	5/16 x 7/32	180-0016		
1-7/16	3/8 x 1/4	180-0017		H-2
1-1/2	3/8 x 7/32	180-0018		
3/4	1/2 x 3/8	180-0026	QI-1	
13/16	1/2 x 3/8	180-0027		
7/8	1/2 x 3/8	180-0028		
15/16	1/2 x 3/8	180-0029		
1	1/2 x 3/8	180-0030		
1-1/16	1/2 x 3/8	180-0031		
1-1/8	1/2 x 3/8	180-0032		
1-3/16	1/2 x 3/8	180-0033		
1-1/4	1/2 x 3/8	180-0034		
1-5/16	1/2 x 3/8	180-0035		
1-3/8	1/2 x 3/8	180-0036		
1-7/16	1/2 x 3/8	180-0037		
1-1/2	1/2 x 3/8	180-0038		
1-9/16	1/2 x 3/8	180-0039		
1-5/8	1/2 x 3/8	180-0040		
1-11/16	1/2 x 3/8	180-0041		
1-3/4	1/2 x 3/8	180-0042		
1-13/16	1/2 x 3/8	180-0043		
1-7/8	1/2 x 3/8	180-0044		
1-15/16	1/2 x 3/8	180-0045		
2	1/2 x 3/8	180-0046	QI-2	
2-1/16	1/2 x 3/8	180-0047		
2-1/8	1/2 x 3/4	180-0048		
2-3/16	1/2 x 23/32	180-0049		
2-1/4	1/2 x 11/16	180-0050		
2-5/16	5/8 x 5/16	180-0051		
2-3/8	5/8 x 5/16	180-0052		
2-7/16	5/8 x 5/16	180-0053		
2-1/2	5/8 x 5/16	180-0054		
2-9/16	5/8 x 5/16	180-0055		
2-5/8	5/8 x 5/16	180-0056		
2-11/16	5/8 x 5/16	180-0057		

## Dodge Bushing

Shaft Size	Keyway Size	Bushing Number		
		Warner Electric	Dodge	
1/2	1/8 x 1/16	180-0101	1210	
9/16	1/8 x 1/16	180-0102		
5/8	3/16 x 3/32	180-0103		
11/16	3/16 x 3/32	180-0104		
3/4	3/16 x 3/32	180-0105		
13/16	3/16 x 3/32	180-0106		
7/8	3/16 x 3/32	180-0107		
5/16	1/4 x 1/8	180-0108		
1	1/4 x 1/8	180-0109		
1-1/16	1/4 x 1/8	180-0110		
1-1/8	1/4 x 1/8	180-0111		
1-3/16	1/4 x 1/8	180-0112		
1-1/4	1/4 x 1/8	180-0113		
1/2	1/8 x 1/16	180-0116		1215
9/16	1/8 x 1/16	180-0117		
5/8	3/16 x 3/32	180-0118		
11/16	3/16 x 3/32	180-0119		
3/4	3/16 x 3/32	180-0120		
13/16	3/16 x 3/32	180-0121		
7/8	3/16 x 3/32	180-0122		
15/16	1/4 x 1/8	180-0123		
1	1/4 x 1/8	180-0124		
1-1/16	1/4 x 1/8	180-0125		
1-1/8	1/4 x 1/8	180-0126		
1-3/16	1/4 x 1/8	180-0127		
1-1/4	1/4 x 1/8	180-0128		
1/2	1/8 x 1/16	180-0131	1615	
9/16	1/8 x 1/16	180-0132		
5/8	3/16 x 3/32	180-0133		
11/16	3/16 x 3/32	180-0134		
3/4	3/16 x 3/32	180-0135		
13/16	3/16 x 3/32	180-0136		
7/8	3/16 x 3/32	180-0137		
15/16	1/4 x 1/8	180-0138		
1	1/4 x 1/8	180-0139		
1-1/16	1/4 x 1/8	180-0140		
1-1/8	1/4 x 1/8	180-0141		
1-3/16	1/4 x 1/8	180-0142		
1-1/4	1/4 x 1/8	180-0143		
1-5/16	5/16 x 5/32	180-0144		
1-3/8	5/16 x 5/32	180-0145		
1-7/16	3/8 x 3/16	180-0146		
1-1/2	3/8 x 3/16	180-0147		
1-9/16	3/8 x 3/16	180-0148		
1-5/8	3/8 x 3/16	180-0149		
1/2	1/8 x 1/16	180-0155	2012	
9/16	1/8 x 1/16	180-0156		
5/8	3/16 x 3/32	180-0157		
11/16	3/16 x 3/32	180-0158		
3/4	3/16 x 3/32	180-0159		
13/16	3/16 x 3/32	180-0160		
7/8	3/16 x 3/32	180-0161		
15/16	1/4 x 1/8	180-0162		
1	1/4 x 1/8	180-0163		
1-1/16	1/4 x 1/8	180-0164		
1-1/8	1/4 x 1/8	180-0165		
1-3/16	1/4 x 1/8	180-0166		
1-1/4	1/4 x 1/8	180-0167		





## Warranty

Warner Electric LLC warrants that it will repair or replace (whichever it deems advisable) any product manufactured and sold by it which proves to be defective in material or workmanship within a period of one (1) year from the date of original purchase for consumer, commercial or industrial use.

This warranty extends only to the original purchaser and is not transferable or assignable without Warner Electric LLC's prior consent.

Warranty service can be obtained in the U.S.A. by returning any defective product, transportation charges prepaid, to the appropriate Warner Electric LLC factory. Additional warranty information may be obtained by writing the Customer Satisfaction Department, Warner Electric LLC, 449 Gardner Street, South Beloit, Illinois 61080, or by calling 815-389-3771.

A purchase receipt or other proof of original purchase will be required before warranty service is rendered. If found defective under the terms of this warranty, repair or replacement will be made, without charge, together with a refund for transportation costs. If found not to be defective, you will be notified and, with your consent, the item will be repaired or replaced and returned to you at your expense.

This warranty covers normal use and does not cover damage or defect which results from alteration, accident, neglect, or improper installation, operation, or maintenance.

Some states do not allow limitation on how long an implied warranty lasts, so the above limitation may not apply to you.

Warner Electric LLC's obligation under this warranty is limited to the repair or replacement of the defective product and in no event shall Warner Electric LLC be liable for consequential, indirect, or incidental damages of any kind incurred by reason of the manufacture, sale or use of any defective product. Warner Electric LLC neither assumes nor authorizes any other person to give any other warranty or to assume any other obligation or liability on its behalf.

WITH RESPECT TO CONSUMER USE OF THE PRODUCT, ANY IMPLIED WARRANTIES WHICH THE CONSUMER MAY HAVE ARE LIMITED IN DURATION TO ONE YEAR FROM THE DATE OF ORIGINAL CONSUMER PURCHASE. WITH RESPECT TO COMMERCIAL AND INDUSTRIAL USES OF THE PRODUCT, THE FOREGOING WARRANTY IS IN LIEU OF AND EXCLUDES ALL OTHER WARRANTIES, WHETHER EXPRESSED OR IMPLIED BY OPERATION OF LAW OR OTHERWISE, INCLUDING, BUT NOT LIMITED TO, ANY IMPLIED WARRANTIES OF MERCHANTABILITY OR FITNESS.

Some states do not allow the exclusion or limitation of incidental or consequential damages, so the above limitation or exclusion may not apply to you. This warranty gives you specific legal rights and you may also have other rights which vary from state to state.

### **Changes in Dimensions and Specifications**

All dimensions and specifications shown in Warner Electric catalogs are subject to change without notice. Weights do not include weight of boxing for shipment. Certified prints will be furnished without charge on request to Warner Electric.



[www.warnerelectric.com](http://www.warnerelectric.com)

31 Industrial Park Road  
New Hartford, CT 06057  
815-389-3771