

# Tension Control System X2DRV

Installation and Operation Manual

P-2098-WE-A4

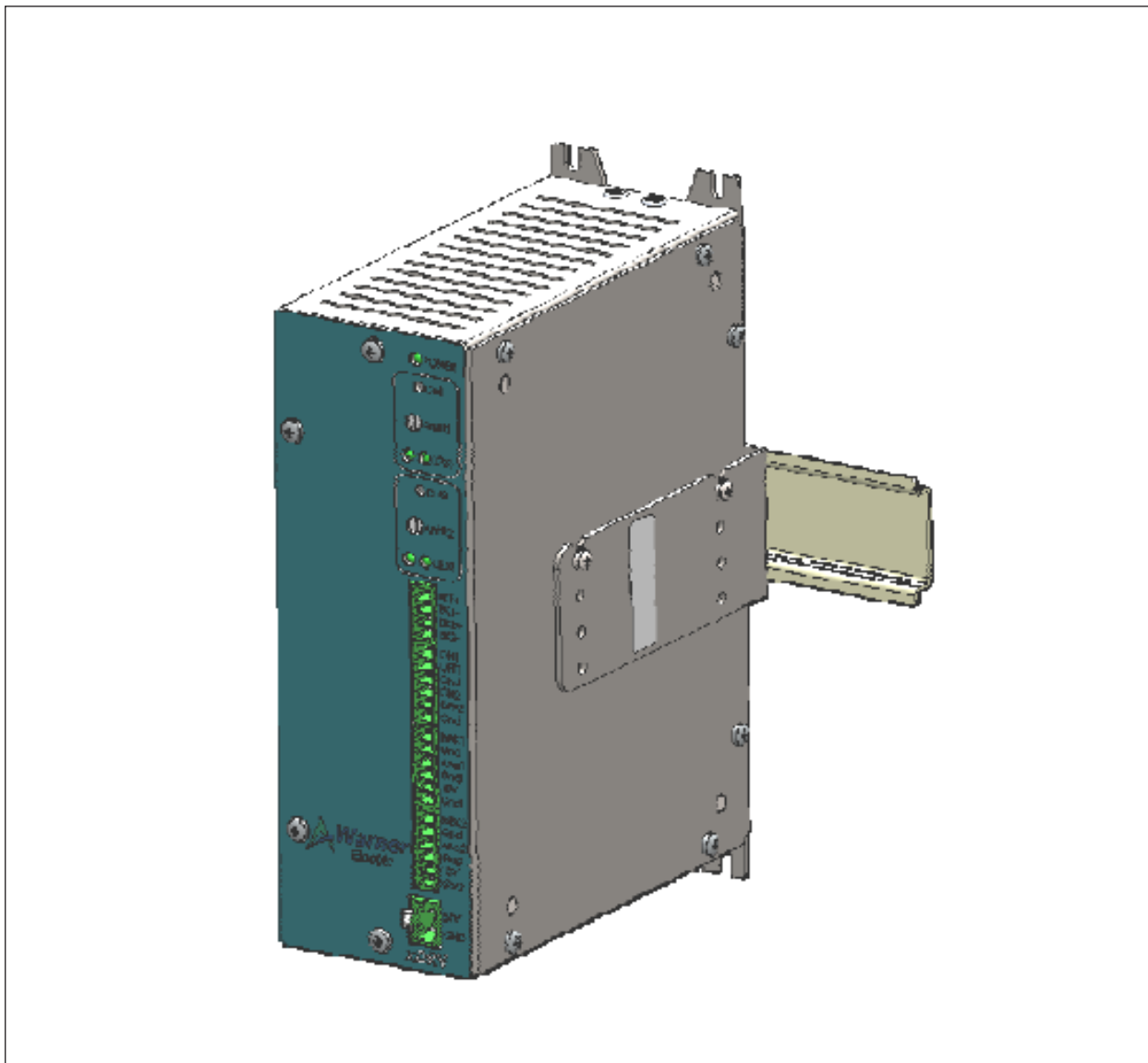

An Altra Industrial Motion Company

**INTRODUCTION:**

The X2DRV is a solid state electronic control that will accept a variety of input signals and provides to the brake an output current and voltage proportional to the input. This double channel driver can be operated by a remote potentiometer, a voltage or a current loop input.

The X2DRV is a 24VDC double channel driver, 4Amps current capability.

When associated with an XCTRL, power supply, Input and (Communication) will be made by the internal connector. This manual has been designed to cover the full range of installation, start-up and operation of your tension control system.

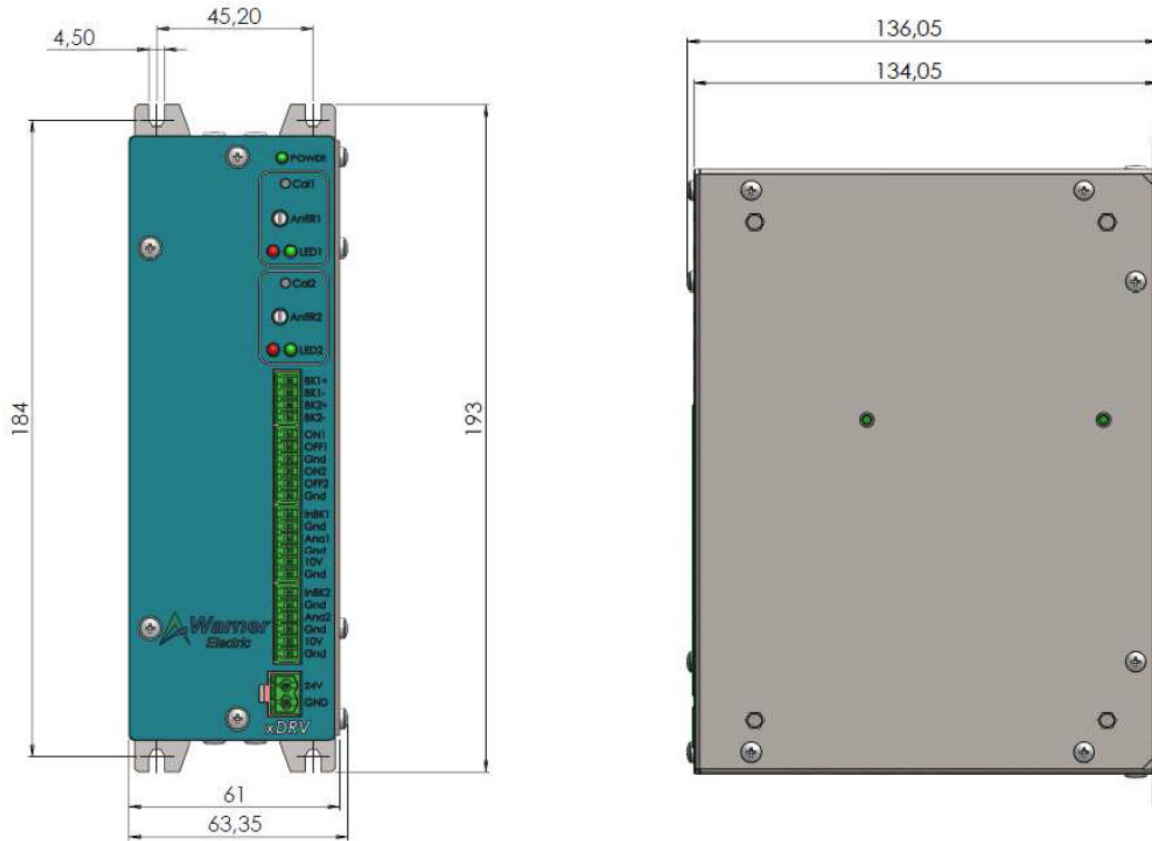





Figure 1: X2DRV housing dimensions

**RATINGS:**

<b>Main Supply Voltage (V)</b>	24V DC +/- 5%
<b>Output</b>	4A with Anti Residual
<b>Operating T°C</b>	-10°C to 50°C no Condensation
<b>Compliance</b>	  

## GENERAL INFORMATION:

Control chassis should be kept clear of all areas where foreign material, dust, grease, or all might affect the operation of the control. Installation must be made in accordance with the instructions found in this manual. Failure to do so may damage the Driver.

This driver supports the following Warner brakes : TB's, ATT's, MPB's, MPC's. POB's, POC's and MTB's brakes cannot be driven by this device.

## INSTALLATION INSTRUCTIONS:

### HARDWARE PIN OUT:

1	BK1+	Power Output	Brake 1 Output + Integrated Anti-residual control. Voltage or Current controlled.
2	BK1-	Power Output	Brake 1 Output –
3	BK2+	Power Output	Brake 2 Output + Integrated Anti-residual control. Voltage or Current controlled.
4	BK2-	Power Output	Brake 2 Output –
5	ON1	Digital input	Full power : 24VDC applied to brake 1 Active low / GND: NPN type Input
6	OFF1	Digital input	Power Off brake 1 : 0V applied to brake 1 with anti-residual Active low /GND: NPN type Input
7	Gnd	Ground	
8	ON2	Digital input	Full power : 24VDC applied to brake 2 Active low /GND: NPN type Input
9	OFF2	Digital input	Power Off brake 2 : 0V applied to brake 2 with anti-residual Active low /GND: NPN type Input
10	Gnd	Ground	
11	InBK1	Analog input	Brake 1 Input signal control. Selectable: 0/+10V DC or 4/20mA.
12	Gnd	Ground	
13	Ana1	Analog input	Brake 1 Auxiliary input : To compensate Brake1 signal in Open Loop control Selectable: 0/+10V DC or 4/20mA. Teachable Span (item 9 page 4).
14	Gnd	Ground	
15	10V	Power out	External interface Power Supply. 10VDC, 100mA Output Used to Power an external potentiometer to get an Open Loop control (local torque adjust)
16	Gnd	Ground	
17	InBK2	Analog input	Brake 2 Input signal control. Selectable: 0/+10V DC or 4/20mA.
18	Gnd	Ground	
19	Ana2	Analog input	Brake 2 Auxiliary input : To compensate Brake2 signal in Open Loop control Selectable: 0/+10V DC or 4/20mA. Teachable Span (item 9 page 4).
20	Gnd	Ground	
21	10V	Power out	External interface Power Supply. 10VDC, 100mA. Used to Power an external potentiometer to get an Open Loop control (local torque adjust)
22	Gnd	Ground	
23	24V	Power supply	24VDC Power supply Input
24	GND	Ground	GROUND

This installation and Operating Manual has been arranged for the systematic installation and start-up of your Tension Control System. Please check off each step before proceeding to the next step.

**SYSTEM WIRING AND SETTING:**

**WARNING:** Contact with electrical voltages present in the driver covered in this manual can cause injury. To avoid these consequences, make sure all power is off during installation.

These wiring precautions will help you properly install and wire a trouble-free system.

1. Use proper gauge wire for all pin :
  - Data input : 0,5mm<sup>2</sup> (20AWG) or 0,75mm<sup>2</sup> (18AWG)
  - Brakes wires : 0,75mm<sup>2</sup> (18AWG) or 1mm<sup>2</sup> (17AWG)
2. Shielded cable is recommended for all connections.
3. Do not use this driver for purposes other than those intended. Such use could damage the driver.

**WIRING:**

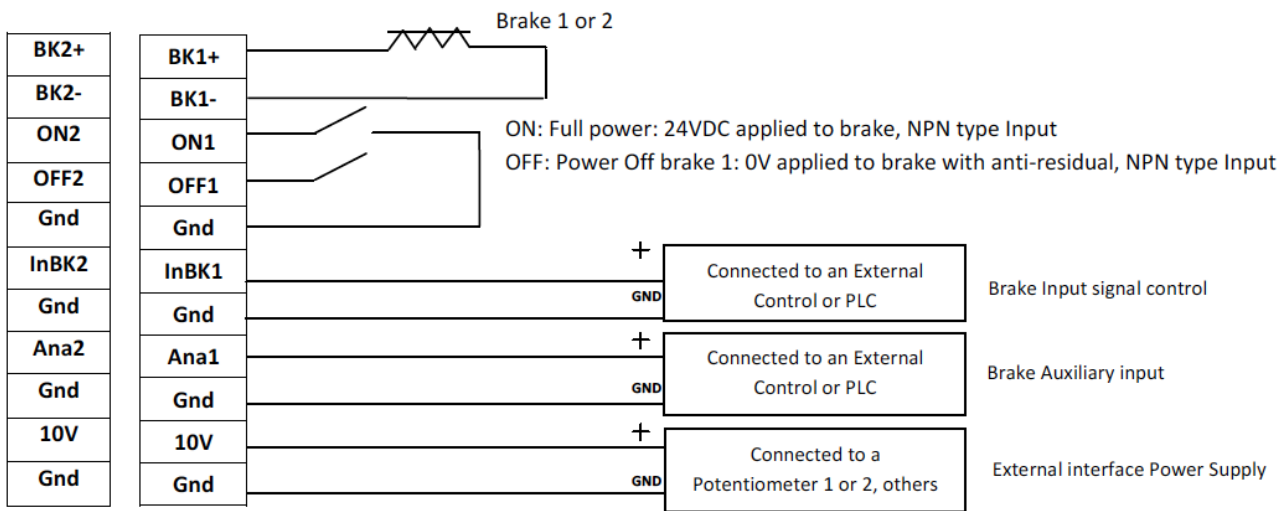
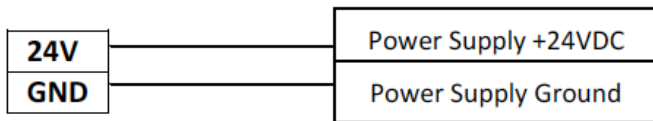

Figure 2: X2DRV wiring – one or two brakes

1. Wire 24V DC input power to pin 24V as shown in Figure 3.



**CAUTION:** Improperly setting the 24VDC can damage the power supply and/or the driver

Figure 3: Power supply wiring

2. Connect wiring from brake magnets to Pin BK1 and/or BK2 of the X2DRV as shown in Figure 2.

3. Select the Input type with the red switches located along the bottom of the control:

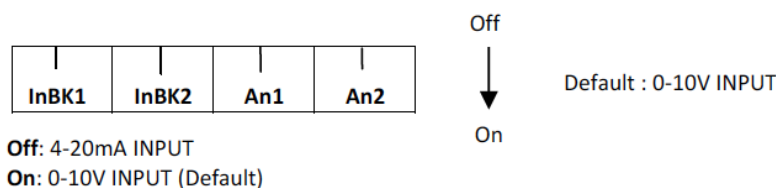

4. Select the Output type with the red switches located along the bottom of the control:

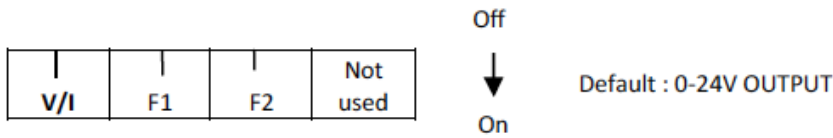

**V/I Off:** Output controlled in Voltage: 0-10VDC or 4-20mA IN => 0-24VDC OUT (Default)

**V/I On:** Output controlled in Current: 0-10VDC or 4-20mA IN => 0-4A OUT

5. Wire Controller or PLC (0-10V or 4-20mA Input) to pin InBK1 or InBK2 as shown in figure.

6. Set the Anti-residual with the white screw as shown in Figure 4 as described below:

- Apply the brake at 0V or 4mA on InBK (1 or 2) or activate the Brake-Off (OFF1 or OFF2).
- Check the Brake armature floats away from the Brake magnet with no sticking.
- If the armature sticks to the magnet, set the Anti-Residual (AntiR1 or AntiR2) as shown below until the armature is free with no sticking.
- Reapply the Brake at 10V or 20mA on InBK (1 or 2) or by returning the Brake-Off (OFF1 or 2) Pin to its normal position and activating the Brake-On input (ON1 or 2).
- If Brake releases freely, make no further adjustments as the Anti-Residual is now set.

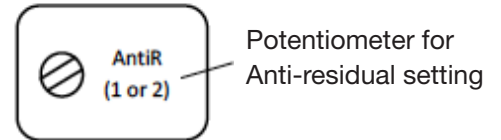
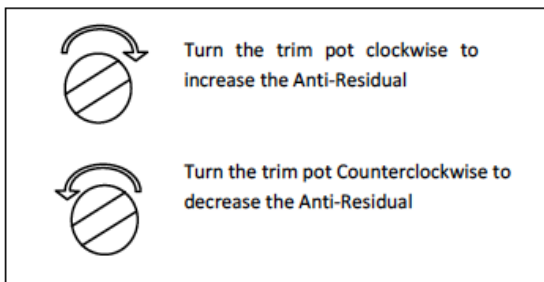
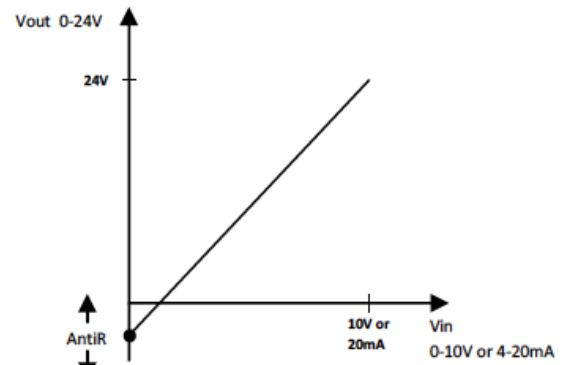

Figure 4: Anti-residual calibration



Anti-Residual adjustment



Voltage Output versus anti-residual control

7. (Optional): Pins ON1, OFF1, ON2, OFF2 are NPN type Input:

- When ON (1 or 2) is set to Ground => 24V is applied on BK (1 or 2) output
- When OFF (1 or 2) is set to Ground => 0V with Anti-residual is applied on BK (1 or 2) output

8. (Optional): To get an Open Loop control use the external interface power supply (10V DC) as shown in Figure 2 to supply a potentiometer or others as described in Figure 5.

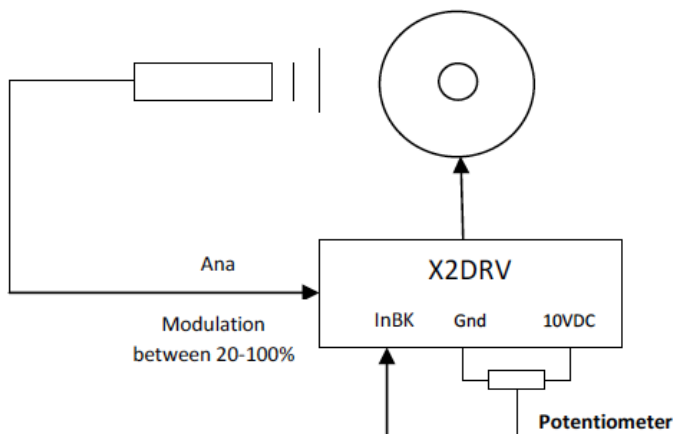







Figure 5: Typical Open Loop application with diameter compensation

## 9. Auxiliary Analog Sensor (Teachable Span)

In case of use an analog sensor or two, wire them to Pin Ana1 or Ana2 and teach their voltage or current span with starting the calibration as describe below (for this use the button Cal as shown figure 6). **If no calibration is done, Ana1 or Ana2 are ignored.** The Analog Input (Ana) compensates the Brake Input signal control (InBK) between 20-100%.

**To Disable Ana1 or Ana2 compensation, please calibrate Ana1 or 2 without any connection (unplugged).**

"Teachable Span" calibration procedure		
<b>Step 1</b>		
With the Auxiliary wired to Ana1 or Ana2 Press Cal button >5s.	 >5s Cal	(rd) Red LED on 
<b>Step 2</b>		
Put Min to Ana1 or Ana2 Short press to valid: Min is learnt	 Short press Cal	(rd) Slow flashing 
<b>Step 3</b>		
Put Max to Ana1 or Ana2 Short press to valid: Max is learnt and calibration is done	 Short press Cal	(rd) Quick flashing 

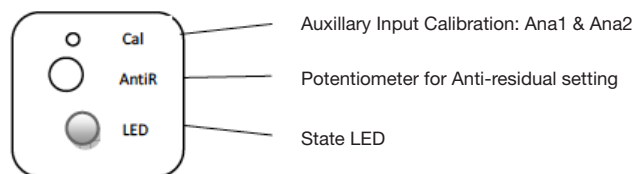











Figure 6: Anti-residual setting and calibration

10. (Optional): The frequency adjustment changes the modulation frequency to eliminate brake "hum" or "howl" when the brake is stationary. The frequency is factory set and normally requires no adjustments. Set the frequency as described below with the red switches below the chassis:

F1			F2	Set 0: Between 250 and 750 HZ
F1			F2	Set 1: Between 1000 and 3000 HZ
F1			F2	Set 2: Between 2500 and 7500 HZ
F1			F2	Set 3: Between 4250 and 10 KHZ (default)

V/I	F1	F2	Off ↓ On
-----	----	----	----------------

 Turn the trim pot clockwise to increase the frequency  
 Turn the trim pot counterclockwise to decrease

11. Double check all wiring connections per Figure 2 and insure all terminals are tight.

**NOTE:** If an over-load occurs (current 4A or more) the Driver output will shut down and the red LED will be ON. To reset the system, remove power to the Driver and turn it on again.

**X2DRV BLOCK DIAGRAM:**

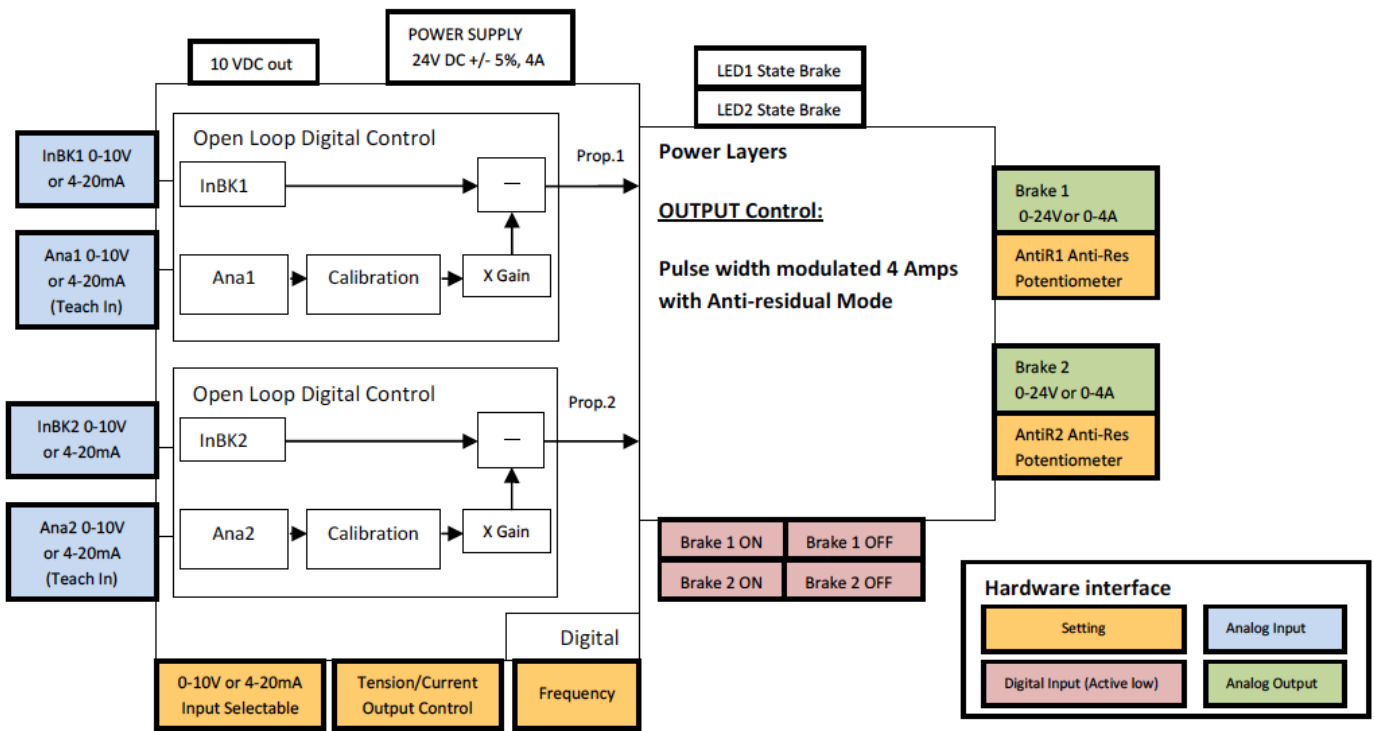

# Warranty

Warner Electric LLC warrants that it will repair or replace (whichever it deems advisable) any product manufactured and sold by it which proves to be defective in material or workmanship within a period of one (1) year from the date of original purchase for consumer, commercial or industrial use.

This warranty extends only to the original purchaser and is not transferable or assignable without Warner Electric LLC's prior consent.

Warranty service can be obtained in the U.S.A. by returning any defective product, transportation charges prepaid, to the appropriate Warner Electric LLC factory. Additional warranty information may be obtained by writing the Customer Satisfaction Department, Warner Electric LLC, 7 rue Champfleu, B.P. 20095, St Barthelemy d'Anjou - France, or by calling +33 (0)2 41 21 24 24.

A purchase receipt or other proof of original purchase will be required before warranty service is rendered. If found defective under the terms of this warranty, repair or replacement will be made, without charge, together with a refund for transportation costs. If found not to be defective, you will be notified and, with your consent, the item will be repaired or replaced and returned to you at your expense.

This warranty covers normal use and does not cover damage or defect which results from alteration, accident, neglect, or improper installation, operation, or maintenance.

Some states do not allow limitation on how long an implied warranty lasts, so the above limitation may not apply to you.

Warner Electric LLC's obligation under this warranty is limited to the repair or replacement of the defective product and in no event shall Warner Electric LLC be liable for consequential, indirect, or incidental damages of any kind incurred by reason of the manufacture, sale or use of any defective product. Warner Electric LLC neither assumes nor authorizes any other person to give any other warranty or to assume any other obligation or liability on its behalf.

WITH RESPECT TO CONSUMER USE OF THE PRODUCT, ANY IMPLIED WARRANTIES WHICH THE CONSUMER MAY HAVE ARE LIMITED IN DURATION TO ONE YEAR FROM THE DATE OF ORIGINAL CONSUMER PURCHASE. WITH RESPECT TO COMMERCIAL AND INDUSTRIAL USES OF THE PRODUCT, THE FOREGOING WARRANTY IS IN LIEU OF AND EXCLUDES ALL OTHER WARRANTIES, WHETHER EXPRESSED OR IMPLIED BY OPERATION OF LAW OR OTHERWISE, INCLUDING, BUT NOT LIMITED TO, ANY IMPLIED WARRANTIES OF MERCHANTABILITY OR FITNESS.

Some states do not allow the exclusion or limitation of incidental or consequential damages, so the above limitation or exclusion may not apply to you. This warranty gives you specific legal rights and you may also have other rights which vary from state to state.

## Changes in Dimensions and Specifications

All dimensions and specifications shown in Warner Electric catalogs are subject to change without notice. Weights do not include weight of boxing for shipment. Certified prints will be furnished without charge on request to Warner Electric.



Warner Electric  
7 rue Champfleu, B.P. 20095, St Barthelemy d'Anjou - France  
+33 (0)2 41 21 24 24 • Fax: +33 (0)2 41 21 24 70  
[www.warnerelectric.com](http://www.warnerelectric.com)