

Cummins Electromagnetic Fan Clutch Fan Hub Bearing Replacement

Installation Instructions

P-2103-WE
819-0547

DISASSEMBLY

To disassemble the clutch, support the clutch on the back of the field assembly between the coil lead wires and the center mounting sleeve. Using a rod that fits inside the inner race of the bearing, press down on the mounting sleeve until the mounting sleeve has cleared the armature bearing. Remove the armature assembly and the spacer that separates the bearings. Continue pressing the mounting sleeve through the rotor bearing and the field support.

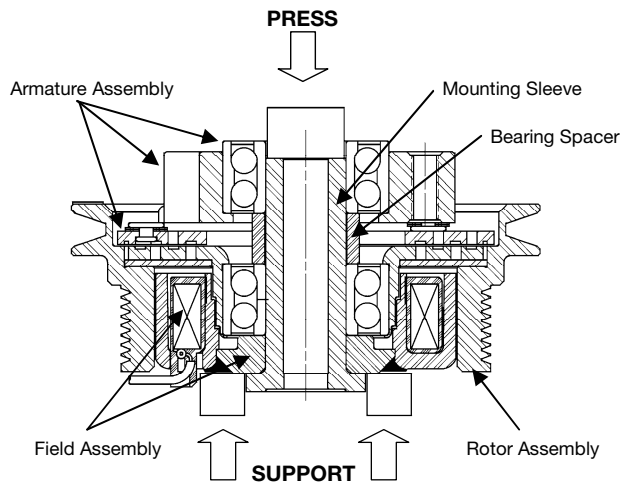

To disassemble the armature assembly, support the armature assembly on the fan spacer mounting surface with the bearing not supported. Press on the inner race of the bearing to remove the bearing. Note: Removing the bearing in this manner will cross load the bearing and the bearing can not be reused.

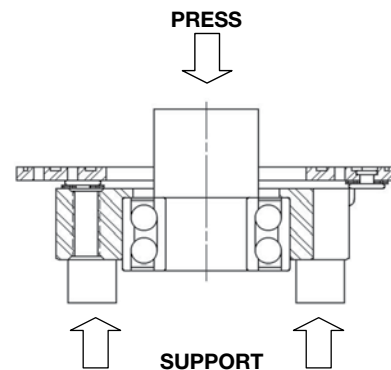

⚠ WARNING Support the clutch only in the area shown and only press on the end of the mounting sleeve to prevent bearing damage.

ASSEMBLY

Clean any remaining Loctite from the I.D. of the fan hub. Support the fan hub in the area between the I.D. of the armature. Press the bearing into the fan hub by pressing on the outer race of the bearing only. DO NOT press on the INNER RACE of the bearing. (With the bearing pressing fixture on the O.D. of the bearing the Inner Race of the bearing should turn freely). Press the bearing into the fan hub until the outer race seats against the bearing shoulder.

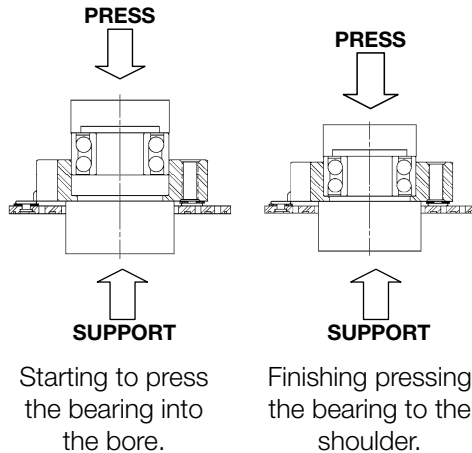

Inspect all of the bearings for smooth rotation of the inner race. Clean any remaining Loctite from the O.D. of the mounting sleeve, the I.D. of the field support and the I.D. of the bearing spacer.

Support the flanged end of the mounting sleeve and press the field assembly onto the mounting sleeve. Next, press the rotor assembly onto the mounting sleeve. Then place the bearing spacer on the mounting sleeve. Finally, press the armature assembly onto the mounting sleeve and press the entire clutch assembly together. There should not be a gap between the mounting sleeve flange and the field support. Rotate both the armature and the rotor and check for free and independent rotation. If the parts do not spin freely or there is any drag between the rotor and the armature, disassemble the clutch and examine all of the parts for signs of damage.

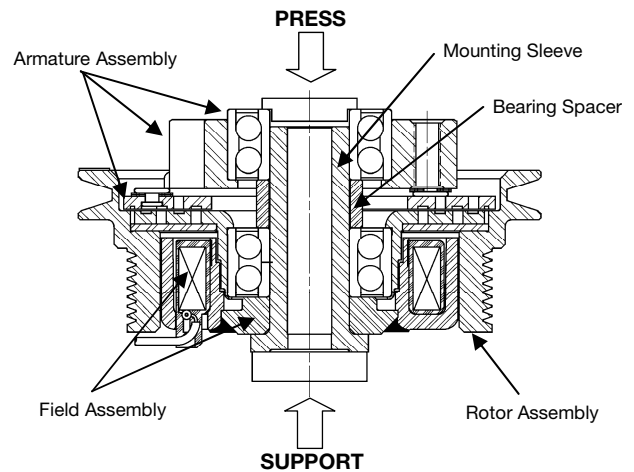

⚠ WARNING Support the clutch on the flanged end of the mounting sleeve and only press on the inner race of the bearing to prevent bearing damage. **DO NOT** press on the outer bearing race!



www.warnerelectric.com

31 Industrial Park Road
New Hartford, CT 06057
815-389-3771
Fax: 815-389-2582

An Altra Industrial Motion Company

