

⚠ WARNING Failure to follow these instructions may result in product damage, equipment damage, and serious or fatal injury to personnel.



Scan to view Installation Video
or visit www.warnerptodirect.com/install

Critical Requirements

The most important requirements for a successful installation are the following:

1. Anti-rotation device must allow for axial and radial free play.
Failure to allow this free play will result in field bearing failure.
2. Mounting bolt torque to be properly installed to value in chart 1.

Chart 1

Thread size	Grade Class	Torque lb.ft.	Torque N-m
7/16-20 UNF	Grade 5 or 8	55-60 ft.lb.	61-66 N-m
M 10 X 1.50	Grade 10.9	40-48 ft.lb.	75-81 N-m
1/2-20 UNF	Grade 5 or 8	85-90 ft.lb.	115-122 N-m
M 12 X 1.75	Grade 10.9	78-82 ft.lb.	105-111 N-m
5/8-18 UNF	Grade 5 or 8	103-110 ft.lb.	139-149 N-m
M 16 X 2.0	Grade 10.9	137-161 ft.lb.	185-218 N-m

Note: All values are for dry plated bolts (unlubricated). Please consult fastener manufacture if any type of locking element (thread lock compound, patch etc.) is to be used.

⚠ WARNING Failure to properly torque bolt can allow the clutch to separate from shaft causing product damage, equipment damage and personnel injury.

3. **Electrical inspection: Voltage should be 12 to 14Vdc with engine at full throttle and PTO engaged. If voltage is less than 12Vdc, repair electrical circuit, battery, PTO switch, or engine.**

⚠ WARNING Failure to follow these instructions may result in product damage, equipment damage, and serious or fatal injury to personnel.

1. Prepare to remove old clutch/brake by referring to the garden tractor manufacturer's repair manual or exploded view.
2. Inspect all wiring to clutch/brake for pinched wires, broken connectors / wires, corrosion in connectors. Clean or repair as needed.
3. Remove clutch/brake and note order in which you remove components. Note orientation of pulley. **See Figure 2.**
4. Inspect engine shaft, spacers, ground drive pulley (if used) for any damage. Engine shaft should not have any burrs, gouges, rust, fretting, etc. Spacers and ground drive pulley should have square shoulders and clean bores. All items should have nice smooth fit on motor shaft. Replace as necessary. **See Figure 1.**
5. Remove new clutch/brake from box and verify that it is the correct replacement and in new condition.
6. Assemble clutch/brake, spacers, and pulley onto motor shaft in same order as removed. If unknown, please refer to mower manufacturer's installation manual or exploded view of mower model.
7. The clutch/brake product is manufactured to be directional and will only be designed for one direction. **See Figure 2.**

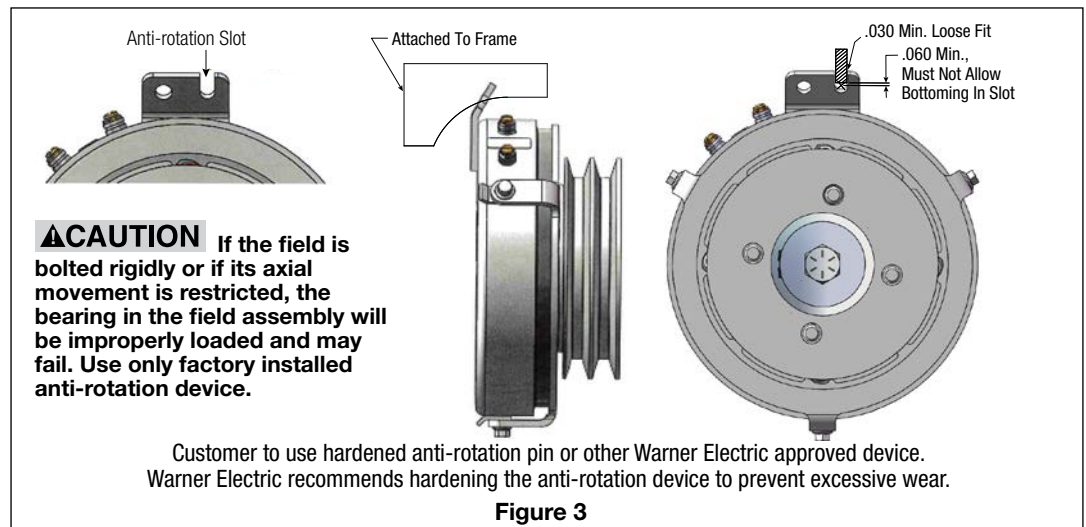
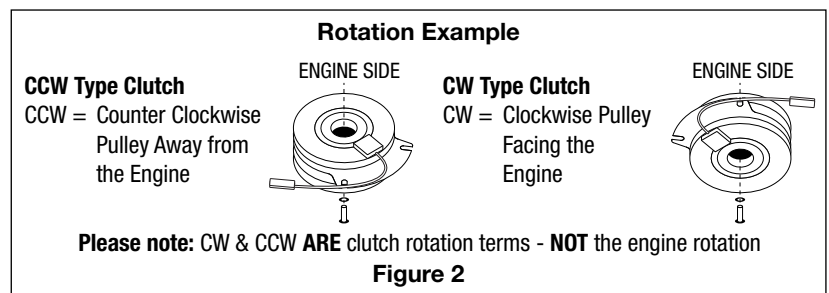
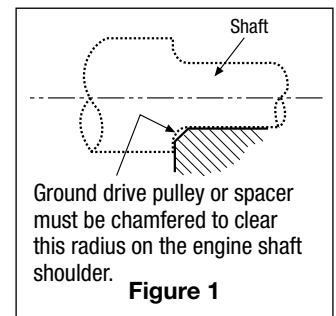

⚠ WARNING Failure to follow these instructions may result in product damage, equipment damage, and serious or fatal injury to personnel.

8. Clutch/brake should fit into anti-rotation device as shown and allow for free play in a rotational direction. **See Figure 3** for one example of anti-rotation device.

Note: Failure to allow this free play will result in field bearing failure.

9. End of engine shaft and washer if equipped, should NOT touch. **See Figure 4.** If this occurs, clutch will not have the correct amount of clamp pressure when bolt is installed and torqued to correct value.
10. Secure clutch/brake to shaft, install correct bolt and torque bolt to correct value in **Chart 1.**

Note: Prevent the engine shaft from rotating during the installation bolt torquing process.

Note: DO NOT USE AIR OR ELECTRIC IMPACT DRIVE.

▲WARNING Failure to follow these instructions may result in product damage, equipment damage, and serious or fatal injury to personnel.

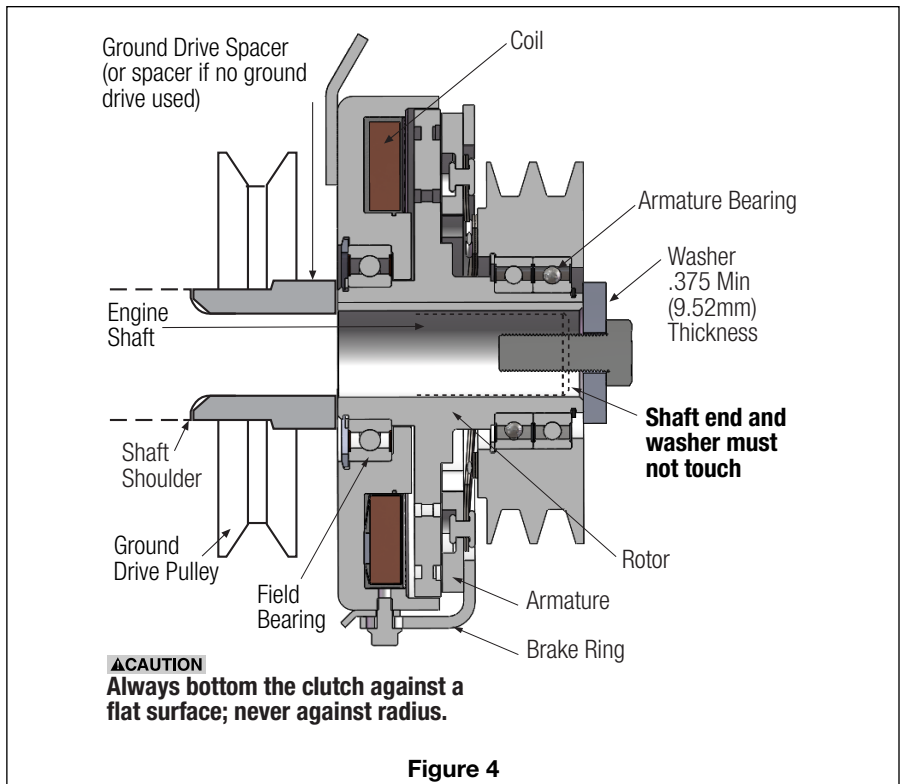

Figure 4

11. Once above has been completed, ensure all wires to clutch/brake are secure and allow for some movement as clutch will oscillate slightly. Secure wires in place as necessary with clamps or wire ties. Do not damage wires during this process.
12. Inspection of mower deck. Ensure that all fasteners are secure, belts are not damaged, and all pulleys turn freely. Any pulleys that are damaged or bearings that are noisy or have large amount of drag should be replaced.
13. Install belt per mower manufacturer's installation manual or exploded view.
14. Burnishing of new clutch/brake will be required. This procedure will be performed with load attached. (mower deck, snowblower, pump, etc.) **DO NOT ADD ADDITIONAL LOAD** (e.g. cutting grass)
 - A. Run engine at full throttle and engage load (PTO switch on). Allow engine and mower deck load to come to full speed then disengage load (PTO switch off).
 - B. Let mower deck load come to full stop (PTO switch off). Engage mower deck load again (PTO switch on).
 - C. Repeat steps A & B a total of 10 times.

Note: To maximize deck drive train life, always engage clutch at half throttle in normal operation.
15. If any problems occur with any of the above procedures, please refer to trouble shooting guide on our website at www.WarnerPTODirect.com

▲WARNING: Cancer and Reproductive Harm -
www.P65Warnings.ca.gov

Warner Electric[®]
 Altra Industrial Motion

www.WarnerPTODirect.com

4578 East Park 30 Drive
 Columbia City, IN 46725
 888-274-3718