

AT Brakes

Installation Instructions

P-218
819-0334



 **Warner**
Electric

An Altra Industrial Motion Company

Contents

Introduction	2
Brake Installation	3
AT Brake Troubleshooting Guide	5
Warranty	Back Page

⚠ WARNING Failure to follow these instructions may result in product damage, equipment damage, and serious or fatal injury to personnel.

The Warner Electric AT brake you have purchased has been designed to provide long and trouble-free service. It is a rugged and durable unit which is rebuildable with both friction face replacement and complete brake rebuild kits offered in this service manual. The friction face replacement kit renews the friction surfaces, while the complete brake rebuild kit includes new bearings, Autogap™ components and hardware in addition to the friction faces.

For friction material replacement refer to manual 819-0341.

For complete rebuild refer to manual 819-0325.

This service manual includes instructions required for installation, troubleshooting information.

All installation and repair involving AT brakes must be carried out in accordance with the procedures specified in the service manual. All stated or implied manufacturer warranties are voided if this product is not installed and serviced in accordance with these instructions.

Brake Installation

1. Remove your AT brake from its shipping carton and inspect it thoroughly to ensure that it has arrived in good condition.

An accessory kit included with your brake contains a coil wire retainer. In addition, you may have ordered the optional brake torque arm.

2. If used, install the Warner Electric conduit box or conduit box/CBC-100 control combination in accordance with instructions furnished with the conduit box.
3. The Warner Electric patented Autogap automatically adjusts the proper operating gap between the armature and friction face for the life of these components. The proper gap is approximately .050". If the armature and friction face have moved during shipment, re-set the Autogap by pushing the armature against the friction material face. Release. The armature will spring back about .050" and the proper gap is set.



4. Slide the brake onto its shaft over its key. **If the brake is to be operated in a vertical position, it must be mounted with the armature fins up.**

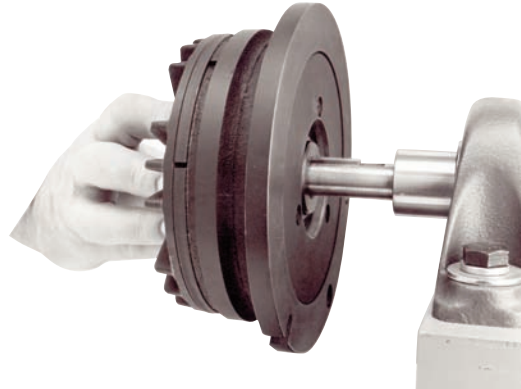

5. Install the optional Warner Electric torque arm or the customer furnished pin. The arm must be strong enough to withstand the brake's full torque capacity, and should be affixed to the machine frame, and to the brake tangent to its circumference in the notched attachment point on the back plate. It must also be flexible enough to compensate normal shaft and bearing runout without causing binding or side loading to the brake.

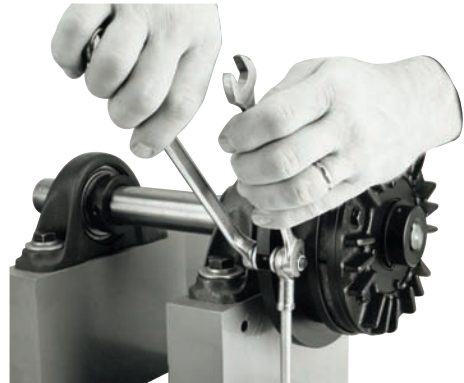

6. Tighten the set screws located in the hub to the appropriate torque for your size unit:

Size	Torque
25	80 in.-lbs.
55	160 in.-lbs.
115	275 in.-lbs.

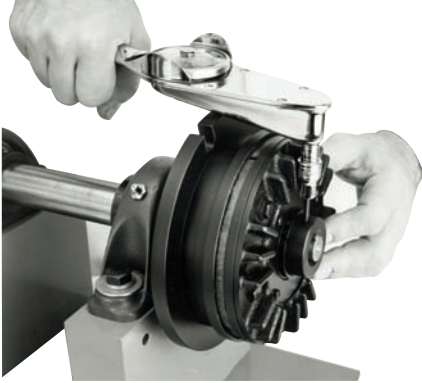

7. Attach the wires to the DC power source, using wire nuts or other approved connecting devices. Either wire can be connected to the + or - of the voltage source. If a Warner Electric CBC-100 or other Warner Electric control is used as the power source, follow the connection diagram supplied with the control. Assure that the voltage rating of the brake is the same as the output rating of the power source.



8. Your AT brake is now ready for its static test. Apply DC voltage to the coil through the brake control. The armature should pull against the friction material face with an audible click.
9. Run the brake under its operating load.

10. Your AT brake may not achieve its full torque until after a short “break-in” period. To break in the brake, cycle it on and off under full load at operating speed a minimum of ten times in quick succession.

Your AT brake is now ready to run.

Note: Depending on application break in period may be longer due to load and RPM, and require more cycles.

Wear Indication

Your AT brake should be visually inspected on a periodic basis to determine if the wearing surfaces warrant replacement. The friction face and armature should be replaced when the armature reaches the wear indicator on the magnet shell. If replacement is not made at this time, further use will wear into the screw heads, making removal and replacement of the friction facing difficult. The drawing below illustrates the area to be inspected.

When the friction surfaces are worn to this point, replace with the appropriate friction face replacement kit. All of the components needed to refurbish the wearing surfaces of your brake are provided in the replacement kit.

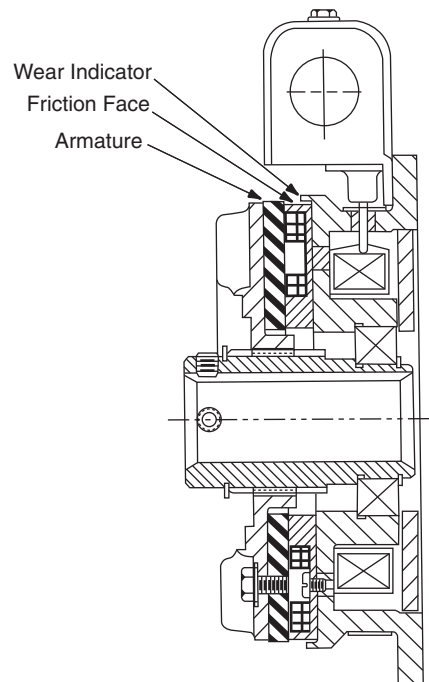

AT Brake Troubleshooting Guide

If performance problems are present after carefully following the instructions in this manual, use the following check list.

Symptom	Check
Problem Clutch Rotor will not move or engage when power is applied to the coil	Possible Causes <ul style="list-style-type: none"> • Coil Resistance Coil may be open. See Chart 1. • Power Supply Assure proper DC voltage is being delivered to the brake • Airgap If greater than .050" around entire periphery, reset Autogap. • Autogap Assure that brake armature is free to move on hub spline and releases approximately .050" when pressure is removed.
Vibration	<ul style="list-style-type: none"> • Runout Assure that shaft on which the clutch is mounted doesn't have excessive runout. • Shaft Engagement Assure adequate shaft length and diameter engagement in the hub.
Excessive Start or Stop Times	<ul style="list-style-type: none"> • Power Supply Assure proper DC voltage is being delivered to the brake. • Adequate Burnishing Unit must be run and cycled a few times to achieve full rated torque. • Friction Surfaces Replacement may be required. • Friction Surfaces Installation of replacement friction material or armature segments may be incorrect and not allow full contact.

Clutch/Brake Size	Coil Voltage	Approx. Coil Resistance (Ohms)
25	6	1.4
25	24	20.6
25	90	290
55	6	1.2
55	24	19.6
55	90	230
115	6	1.0
115	24	16.5
115	90	182

Chart 1

Warranty

Warner Electric LLC warrants that it will repair or replace (whichever it deems advisable) any product manufactured and sold by it which proves to be defective in material or workmanship within a period of one (1) year from the date of original purchase for consumer, commercial or industrial use.

This warranty extends only to the original purchaser and is not transferable or assignable without Warner Electric LLC's prior consent.

Warranty service can be obtained in the U.S.A. by returning any defective product, transportation charges prepaid, to the appropriate Warner Electric LLC factory. Additional warranty information may be obtained by writing the Customer Satisfaction Department, Warner Electric LLC, 449 Gardner Street, South Beloit, Illinois 61080, or by calling 815-389-3771.

A purchase receipt or other proof of original purchase will be required before warranty service is rendered. If found defective under the terms of this warranty, repair or replacement will be made, without charge, together with a refund for transportation costs. If found not to be defective, you will be notified and, with your consent, the item will be repaired or replaced and returned to you at your expense.

This warranty covers normal use and does not cover damage or defect which results from alteration, accident, neglect, or improper installation, operation, or maintenance.

Some states do not allow limitation on how long an implied warranty lasts, so the above limitation may not apply to you.

Warner Electric LLC's obligation under this warranty is limited to the repair or replacement of the defective product and in no event shall Warner Electric LLC be liable for consequential, indirect, or incidental damages of any kind incurred by reason of the manufacture, sale or use of any defective product. Warner Electric LLC neither assumes nor authorizes any other person to give any other warranty or to assume any other obligation or liability on its behalf.

WITH RESPECT TO CONSUMER USE OF THE PRODUCT, ANY IMPLIED WARRANTIES WHICH THE CONSUMER MAY HAVE ARE LIMITED IN DURATION TO ONE YEAR FROM THE DATE OF ORIGINAL CONSUMER PURCHASE. WITH RESPECT TO COMMERCIAL AND INDUSTRIAL USES OF THE PRODUCT, THE FOREGOING WARRANTY IS IN LIEU OF AND EXCLUDES ALL OTHER WARRANTIES, WHETHER EXPRESSED OR IMPLIED BY OPERATION OF LAW OR OTHERWISE, INCLUDING, BUT NOT LIMITED TO, ANY IMPLIED WARRANTIES OF MERCHANTABILITY OR FITNESS.

Some states do not allow the exclusion or limitation of incidental or consequential damages, so the above limitation or exclusion may not apply to you. This warranty gives you specific legal rights and you may also have other rights which vary from state to state.

Changes in Dimensions and Specifications

All dimensions and specifications shown in Warner Electric catalogs are subject to change without notice. Weights do not include weight of boxing for shipment. Certified prints will be furnished without charge on request to Warner Electric.



Warner Electric LLC
449 Gardner Street • South Beloit, IL 61080
815-389-3771 • Fax: 815-389-2582
www.warnerelectric.com
An Altra Industrial Motion Company