

# MCS-103-1 Power Supply with Single Torque Control

P-239-18  
819-0478

## Installation and Operation Manual

Part Number:  
6010-448-002

- Easy to install
- Compact unit mounts anywhere
- Convenient terminal strip behind an easy-to-remove cover
- Internal arc suppression
- Operates with any Warner Electric 90V Clutches or Brakes



The MCS-103-1 is an enclosed power supply complete with a cover and mounting provisions. A brake and clutch may be operated separately with this power supply-or, two brakes or two clutches, one unit on at a time, or clutch and ER brake with both units on at a time. The external wiring is connected to the terminal strip located behind the cover.



### Specifications

AC INPUT	DC OUTPUT	DIMENSIONS (Approx.)	MOUNTING	EXTERNAL SWITCHES (Furnished by user)
120 VAC 50-60 HZ	1.25 amps 90 VDC for one unit and adjustable from 0-90 VDC full wave for second unit.	4-1/2" high 6-3/4" wide 2-3/4" deep	Mounting centers 5-1/2" wide, 3" high. Knockouts for 1/2" conduit.	Double pole, double throw maintained contact. Minimum contact rating:10 amp, 28 volt DC resistive or 10 amp, 120 volt AC inductive.*

\* Contact ratings given will operate all Warner Electric brake and clutch units. However, switches with ratings less than those given may be used with fractional horsepower units provided the rating is equal to or greater than the coil current.

### Dimensional

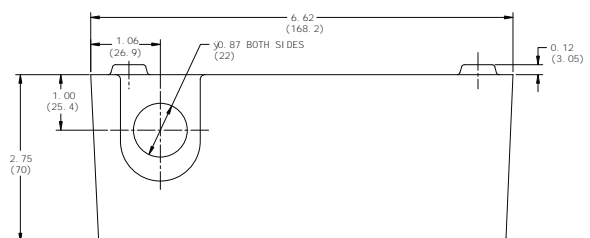
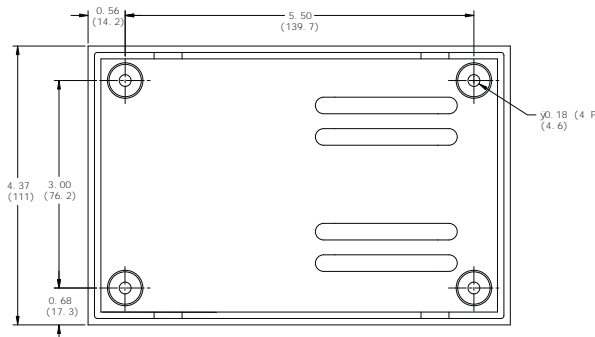

## MCS-103-1 Connection Instructions for use with Standard Clutch-Brake combination

### Wiring Diagram

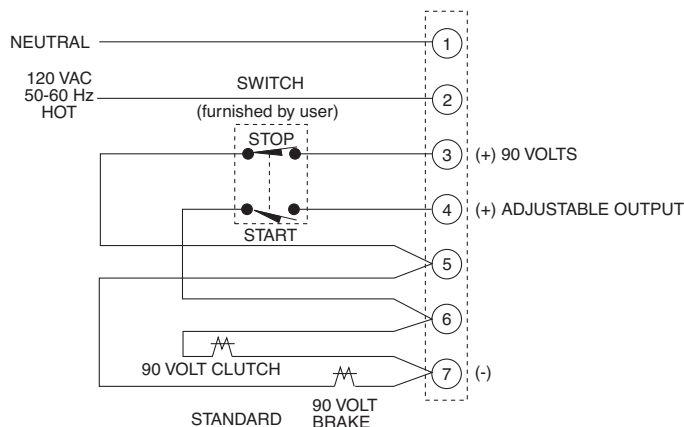

1. Connect the two wires from the brake to terminals 5 and 7.
2. Connect the two wires from the clutch to terminals 6 and 7.
3. The switch (furnished by user) is connected between terminals 3 & 5 and 4 & 6 as shown in the connection diagram.
4. Connect the AC input to socket terminals 1 and 2. The "hot line" must be connected to terminal 2. This line measures 120VAC to conduit ground. The "neutral" line (color coded white or natural-gray) is grounded at the 120 VAC supply transformer and must be connected to terminal 1. This line measures zero VAC to conduit ground. A chassis ground should be provided as a non-current conducting ground wire (color coded green).

## MCS-103-1 Connection Instructions for use with Clutch-ER Brake combination

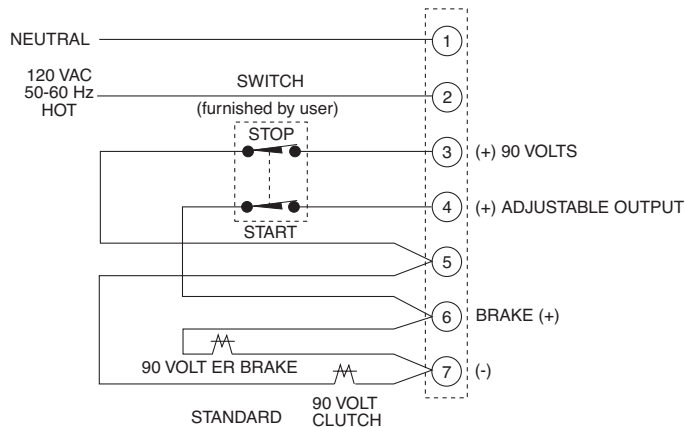

### Wiring Diagram

1. Connect the two wires from the brake to terminals 6 and 7, brake (+) to terminal 6, and brake (-) to terminal 7.
2. Connect the two wires from the clutch to terminals 6 and 7.
3. The switch (furnished by user) is connected between terminals 3 & 5 and 4 & 6 as shown in the connection diagram.
4. Connect the AC input to socket terminals 1 and 2. The "hot" line must be connected to terminal 2. This line measures 120VAC to conduit ground, The "neutral" line (color coded white or natural-gray) is grounded at the 120 VAC supply transformer and must be connected to terminal 1. This line measures zero VAC to conduit ground. A chassis ground should be provided as a non-current conducting ground wire (color coded green).

NOTE: For proper operation, observe polarity for connection of ER brake to power supply terminal strip.

## DECLARATION OF CONFORMITY

WE: **WARNER ELECTRIC**  
**31 Industrial Park Road**  
**New Hartford, Ct 06057**

declare under our sole responsibility that the products of the family  
**MCS 103-1**

are exclusively designed for incorporation in another machine. The operation of the product is submitted to the conformity of the complete equipment, following the provisions of the directive **89/392/EEC**.

The conformity of the above specified products with the provisions of the Directive **72/23/EEC** is supported by the full respect of the standards **EN 61010-1**.

If the mounting and connecting instructions of the installation manual have been respected, this product will be conforming to the standards **EN50081-1** and **EN50082-1** relating to the EMC directive **89/336/EEC**.

New Hartford, CT 06057  
VP and General Manager: M. T.



**⚠ WARNING** To avoid injury, always make certain all power is off before attempting to install or repair this control.

**DO NOT TOUCH THE BOARD IF POWER IS APPLIED.**

### Mounting and Connecting Instructions

related to the EMC-directive 89/336/EEC

#### For Clutch and Brake Control

1. The control must be mounted in a closed metal cabinet.
2. The power connection between control and clutch/brake must be MADE using shield cable.
3. The control connection must utilize shielded cables.
4. The shield of the cables must be grounded at both ends.
5. Power connections and control connection must be placed in separate canals.

## KONFORMITÄTSERKLÄRUNG

Wir: **WARNER ELECTRIC**  
**31 Industrial Park Road**  
**New Hartford, CT 06057**

erkären in alleiniger Verantwortung, daß die Produkte der Familie  
**MCS 103-1**

ausschließlich zum Einbau in eine andere Maschine bestimmt sind. Die Inbetriebnahme ist solange untersagt, bis die Konformität des Endproduktes mit der Richtlinie **89/392/EWG** gegeben ist.

Die Übereinstimmung des bezeichneten Produktes mit den Vorschriften der Richtlinie **72/23/EWG** wird nachgewiesen durch die Einhaltung der Normen **EN 61010-1**.

Sofern die Montage-Anweisungen der Bedienungsanleitung eingehalten wurden, ist dieses Produkt konform zu **EN50081-1** und **EN50082-1** und die EMV somit gewährleistet - Richtlinie **89/336/EWG**.

New Hartford, CT 06057  
VP and General Manager: M. T.



**⚠ WARUNG:** Vor Einbau oder Wartung des Gerätes unbedingt die Stromversorgung unterbrechen um Verletzungen zu vermeiden.

**KARTE BEI EINGESCHALTETER STROMVERSORGUNG NICHT BERÜHREN.**

### MONTAGE UND KABELVERBINDUNGEN ANWEISUNGEN

bezogen zu den EMW Richtlinie 89/336/EWG

#### FÜR STEUERGERÄTE KUPPLUNGEN UND BREMSEN

1. Das Gerät muß in einem geschlossenen metallschrank eingebaut werden.
2. Leistungsverbindungen Steuergeräte/Kupplungen - Bremsen mit abgeschirmten Kabeln durchführen.
3. Steuerleitungen, Ein- und Ausgänge mittels abgeschirmten Kabeln durchführen.
4. Abschirmung an beiden Enden des Kabels erden.
5. Leistungs- und Stromverbindungen in separate Kabelkanäle durchziehen.

## DECLARACION DE CONFORMIDAD

Nosotros: **WARNER ELECTRIC**  
**31 Industrial Park Road**  
**New Hartford, CT 06057**

declaramos bajo nuestra propia responsabilidad que los productos de la familia  
**MCS 103-1**

son diseñados exclusivamente para incorporarse en otra maquina. El funcionamiento de este producto esta sujeto al cumplimiento de todo el equipo usado en la maquina, con los lineamientos de la norma **89/392/EEC**.

El cumplimiento de los lineamientos de la norma **72/23/EEC** con los productos mencionados anteriormente, se basa y respeta los estandares **EN 61010-1**.

Si las instrucciones de montaje e instalación electrica del instructivo son respetadas, este producto cumplirá con los estandares **EN50081-1** y **EN50082-1** que se relacionan con la norma **89/336/EEC**.

New Hartford, CT 06057  
VP and General Manager: M. T.



**⚠ ADVERTENCIA:** Para evitar cualquier daño personal, antes de intentar instalar o reparar este control, siempre asegurese que todas las fuentes de poder esten apagadas.

**NO TOQUE EL CIRCUITO ELECTRICO SI LA FUENTE DE PODER ESTA ENCEDIDA.**

### INSTRUCCIONES DE MONTAJE Y CONEXIONES ELECTRICAS

en relación a la norma de EMC 89/336/EEC

#### PARA CONTROLES DE CLUTCHES Y FRENOS

1. El control debe de instalarse adentro de una caja metalica.
2. Las conexiones electricas entre el control y el cluch/freno DEBEN hacerse con cable blindado.
3. Las conexiones de bajo voltaje en el control deben utilizar cables blindados.
4. El blindaje de los cables debe de aterrizarse en ambos lados.
5. Las conexiones entre la fuente de poder, y las conexiones de bajo voltaje deben de hacerse en diferentes cables.

## DÉCLARATION DE CONFORMITÉ

Nous: **WARNER ELECTRIC**  
**31 Industrial Park Road**  
**New Hartford, CT 06057**

déclarons sous notre seule responsabilité que les produits de la famille  
**MCS 103-1**

sont uniquement destinés à l'intégration dans une machine. La mise en service de ces produits est subséquent à l'homologation de l'ensemble de l'équipement, conformément à la directive **89/392/CEE**.

La conformité des produits spécifiés ci-dessus avec les exigences de la directive **72/23/CEE** est supportée par le respect des normes **EN 61010-1**.

Si les instructions de montage et de câblage du manuel sont respectées, ce produit est conforme aux normes **EN50081-1** et **EN50082-1** directive **89/336/CEE** relative à la CEM.

New Hartford, CT 06057, VP and General Manager: M. T.



**⚠ ADVERTISSEMENT:** Afin d'éviter des blessures, s'assurer que toute puissance soit coupée avant installation ou intervention sur ces équipements.

**NE PAS TOUCHER LE CIRCUIT ÉLECTRONIQUE, SI LA PUISSANCE EST APPLIQUÉE.**

### INSTRUCTIONS D'INSTALLATION ET DE CABLAGE

relatives à la CEM, directive 89/336/CEE

#### DES CONTROLES POUR EMBRAYAGES ET FREINS

1. L' appareil doit être monté dans une armoire métallique close.
2. Liaison de puissance entre contrôle et embrayage/frein par câble blindé.
3. Raccordements de consigne, entrées et sorties par câbles blindés.
4. Les blindages sont reliés à la terre aux deux extrémités du câble.
5. Les câbles de commande et les câbles de puissance ne seront pas placés dans le même caniveau.

# Warranty

Warner Electric LLC warrants that it will repair or replace (whichever it deems advisable) any product manufactured and sold by it which proves to be defective in material or workmanship within a period of one (1) year from the date of original purchase for consumer, commercial or industrial use.

This warranty extends only to the original purchaser and is not transferable or assignable without Warner Electric LLC's prior consent.

Warranty service can be obtained in the U.S.A. by returning any defective product, transportation charges prepaid, to the appropriate Warner Electric LLC factory. Additional warranty information may be obtained by writing the Customer Satisfaction Department, Warner Electric LLC, 449 Gardner Street, South Beloit, Illinois 61080, or by calling 815-389-3771.

A purchase receipt or other proof of original purchase will be required before warranty service is rendered. If found defective under the terms of this warranty, repair or replacement will be made, without charge, together with a refund for transportation costs. If found not to be defective, you will be notified and, with your consent, the item will be repaired or replaced and returned to you at your expense.

This warranty covers normal use and does not cover damage or defect which results from alteration, accident, neglect, or improper installation, operation, or maintenance.

Some states do not allow limitation on how long an implied warranty lasts, so the above limitation may not apply to you.

Warner Electric LLC's obligation under this warranty is limited to the repair or replacement of the defective product and in no event shall Warner Electric LLC be liable for consequential, indirect, or incidental damages of any kind incurred by reason of the manufacture, sale or use of any defective product. Warner Electric LLC neither assumes nor authorizes any other person to give any other warranty or to assume any other obligation or liability on its behalf.

WITH RESPECT TO CONSUMER USE OF THE PRODUCT, ANY IMPLIED WARRANTIES WHICH THE CONSUMER MAY HAVE ARE LIMITED IN DURATION TO ONE YEAR FROM THE DATE OF ORIGINAL CONSUMER PURCHASE. WITH RESPECT TO COMMERCIAL AND INDUSTRIAL USES OF THE PRODUCT, THE FOREGOING WARRANTY IS IN LIEU OF AND EXCLUDES ALL OTHER WARRANTIES, WHETHER EXPRESSED OR IMPLIED BY OPERATION OF LAW OR OTHERWISE, INCLUDING, BUT NOT LIMITED TO, ANY IMPLIED WARRANTIES OF MERCHANTABILITY OR FITNESS.

Some states do not allow the exclusion or limitation of incidental or consequential damages, so the above limitation or exclusion may not apply to you. This warranty gives you specific legal rights and you may also have other rights which vary from state to state.

## Changes in Dimensions and Specifications

All dimensions and specifications shown in Warner Electric catalogs are subject to change without notice. Weights do not include weight of boxing for shipment. Certified prints will be furnished without charge on request to Warner Electric.



**Warner Electric LLC**  
31 Industrial Park Road • New Hartford, CT 06057  
815-389-3771 • Fax: 815-389-2582  
[www.warnerelectric.com](http://www.warnerelectric.com)  
**An Altra Industrial Motion Company**