

# WARNER

## INSTALLATION & OPERATION MANUAL

### *Modular Tension Brake Control Systems TCS-167/TCS-210/TCS-220*

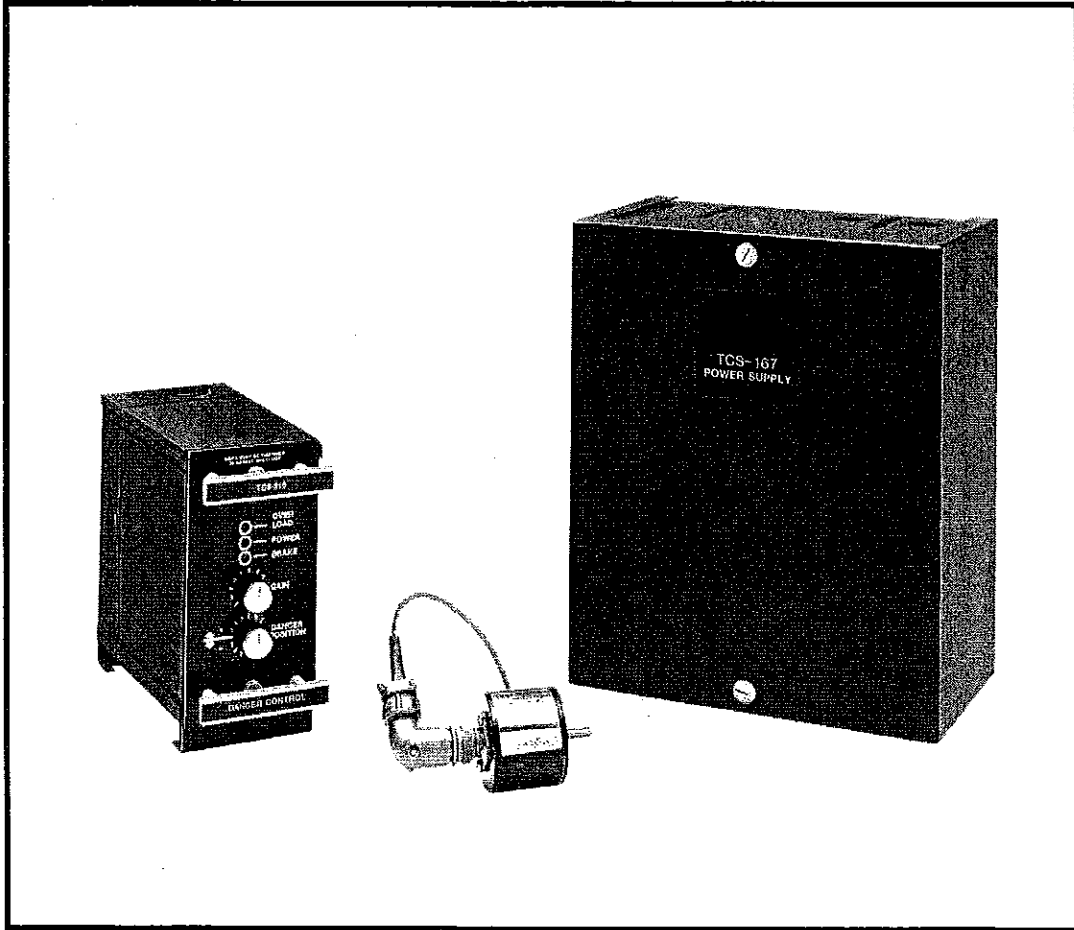

 **Warner**  
Electric

# Modular Tension Brake Control Systems Installation and Operating Instructions

## TABLE OF CONTENTS

Description	Page
Warranty Information .....	3
Introduction .....	4
Theory of Operation .....	4-5
Technical Specification .....	5-6
Installation	
Control Housings .....	7-9
Power Supply .....	10
Sensor .....	11
System Wiring	
TCS-167 .....	12
TCS-210 .....	12-13
TCS-220 .....	14-16
System Start-Up and Adjustment	
TCS-167/TCS-210 .....	17-19
TCS-167/TCS-220 .....	20-22
System Troubleshooting	
TCS-167/TCS-210 .....	23-24
TCS-167/TCS-220 .....	25
Replacement Parts Listing .....	26
Listing of Figures and Illustrations .....	26

**Follow the installation instructions in this manual carefully to ensure safe, reliable operation. All stated or implied manufacturer warranties are voided if this product is not installed in accordance with these instructions.**

**WARNING: Contact with the electrical voltages present in the controls covered in this manual can cause injury or death. To avoid these consequences, make sure all power is off during installation.**

### Warranty

Warner Electric, Inc. warrants that it will repair or replace (whichever it deems advisable) any product manufactured and sold by it which proves to be defective in material or workmanship within a period of one (1) year from the date of original purchase for consumer, commercial or industrial use.

This warranty extends only to the original purchaser and is not transferable or assignable without Warner Electric, Inc.'s prior consent.

Warranty service can be obtained in the U.S.A. by returning any defective product, transportation charges prepaid, to the appropriate Warner Electric, Inc. factory. Additional warranty information may be obtained by writing the Customer Satisfaction Department, Warner Electric, Inc., 449 Gardner Street, South Beloit, Illinois 61080, or by calling 815-389-3771.

A purchase receipt or other proof of original purchase will be required before warranty service is rendered. If found defective under the terms of this warranty, repair or replacement will be made, without charge, together with a refund for transportation costs. If found not to be defective, you will be notified and, with your consent, the item will be repaired or replaced and returned to you at your expense.

This warranty covers normal use and does not cover damage or defect which results from alteration, accident, neglect, or improper installation, operation, or maintenance.

Some states do not allow limitation on how long an implied warranty lasts, so the above limitation may not apply to you.

Warner Electric, Inc.'s obligation under this warranty is limited to the repair or replacement of the defective product and in no event shall Warner Electric, Inc. be liable for consequential, indirect, or incidental damages of any kind incurred by reason of the manufacture, sale or use of any defective product. Warner Electric, Inc. neither assumes nor authorizes any other person to give any other warranty or to assume any other obligation or liability on its behalf.

WITH RESPECT TO CONSUMER USE OF THE PRODUCT, ANY IMPLIED WARRANTIES WHICH THE CONSUMER MAY HAVE ARE LIMITED IN DURATION TO ONE YEAR FROM THE DATE OF ORIGINAL CONSUMER PURCHASE. WITH RESPECT TO COMMERCIAL AND INDUSTRIAL USES OF THE PRODUCT, THE FOREGOING WARRANTY IS IN LIEU OF AND EXCLUDES ALL OTHER WARRANTIES, WHETHER EXPRESS OR IMPLIED BY OPERATION OF LAW OR OTHERWISE, INCLUDING, BUT NOT LIMITED TO, ANY IMPLIED WARRANTIES OF MERCHANTABILITY OR FITNESS.

Some states do not allow the exclusion or limitation of incidental or consequential damages, so the above limitation or exclusion may not apply to you. This warranty gives you specific legal rights and you may also have other rights which vary from state to state.

P201

## INTRODUCTION

Warner Electric's modular tension control systems are comprised of the Electro-Disc Tension Brake, power supply, control module, and an input sensor.

### Power Supply

The TCS-167 power supply operates from either 120VAC or 240VAC to supply operating current for the TCS-210 or TCS-220, and the Electro-Disc tension brake.

### Controls

The TCS-210 dancer control is a solid-state electronic control that receives a dancer arm position signal from the pivot-point sensor and transmits an appropriate current to the Electro-Disc Tension Brake. The control logic includes P-I-D circuits for system stability.

The TCS-220 remote/analog control is a solid-state electronic control that converts an analog input signal to an appropriate current for the Electro-Disc Tension Brake. Input options available include local torque adjust, remote torque adjust via an external potentiometer, and a voltage source or current source which would be dependent on the signalling device. This system is open loop and any change in output to the brake must be inputted to the control from the signal source.

This manual has been designed to cover installation, start-up, adjustment and maintenance of your tension control system and covers the control system only. Further information on brake sizing and selection can be found in catalog P-771.

Because of the constant current output, brake torque is not substantially affected by changes in brake temperature. This provides for repeatable brake torque for a given input level.

### Sensor

The MCS-605-1 and TCS-605-5 Pivot-Point Sensors are precision potentiometers enclosed in rugged housings. Each provides dancer position information to the TCS-210 System.

The MCS-605-1 is coupled to the dancer pivot point when rotation is no more than 60 degrees, while the TCS-605-5 covers rotation to 300 degrees.

### Brakes

Electro-Disc Tension Brakes can be used with either the TCS-210 or TCS-220 controls. The brakes convert electrical current supplied by the controls into torque, which retards material flow, maintaining the desired web tension.

## THEORY OF OPERATION

Warner Electric tension control systems are comprised of a power supply, control module, Electro-Disc Tension Brake and input sensor. Depending on the control module used, the type of input sensor may vary.

The TCS-167 power supply operates from either 120 VAC or 240 VAC and the voltage is switch selectable in the power supply. The input voltage is transformed to lower levels via a transformer. These voltages are rectified and filtered to provide 9 VDC and 48 VDC to operate the control modules and the Electro-Disc Tension Brake. Internal fusing and over-voltage protection circuits are employed in the TCS-167 to prevent damage should high line conditions or incorrect voltages be applied to the power supply.

The TCS-210 and TCS-220 control modules are similar with the exception of the logic control boards. Each module is comprised of three printed circuit boards of which two are identical for both TCS-210 and TCS-220. The two units operate somewhat differently because of differences in function. The TCS-210 operates as a closed-loop system, while the TCS-220 is primarily open-loop.

The TCS-210 incorporates P-I-D circuits in its logic card to translate the input signal from the MCS-605-1 and amplify and condition the information for the output driver boards. The dancer position knob on the front panel provides a reference signal for comparison with pivot-point input. By changing this reference, the dancer moves to the set position. This provides a means of adjusting the dancer to its running position.

The gain knob on the front panel adjusts system response by setting control gain. The lower the gain setting, the less responsive the system is; conversely, the higher the gain setting the more responsive it becomes.

Gain adjustment is covered in detail in System Start-Up and Adjustment, pages.

The control logic board also has an "anti-drift" or integrator reset function. This function improves fast start-up response by immediately dropping the integrator output to zero when the input line is grounded. Input switching can be either mechanical or solid-state.

The TCS-220 functions as an analog amplifier, eliminating the P-I-D, dancer position, gain, and anti-drift circuits. Rather, torque-adjust and zero adjust circuits are used. Input to the TCS-220 can be either a voltage or current signal. In the voltage input mode, voltage can be supplied from the external source or from the internal supply via an external potentiometer. When used in a current input mode, current supplied by the external controlling source is fed to the shunt resistor connected at the control's terminal strip. The voltage developed across this resistor by the current passing through it is used as the input signal.

Since this control operates as an amplifier only, the DC input level is amplified and the maximum output at the brake is set by the "torque/span" potentiometer. This control adjusts brake torque when the control is operated in the local torque mode, and as span adjustment when operated in all other input modes. The "torque/span" is used for setting the maximum output level, while the "zero adjust" is used for setting the minimum output level. Output of the logic board is fed to the brake driver boards.

The output driver boards for both the TCS-210 and TCS-220 are identical in operation, but there are differences in the control faceplates and terminal strip connections.

## THEORY OF OPERATION (Cont.)

The driver boards accept control signals from the logic boards and convert them to usable output current for the Electro-Disc Tension Brake. Since control is by current output rather than voltage output, additional circuits are involved.

The output boards contain circuits for the auxiliary brake on and brake off inputs, which override the inputs from the logic boards. The brake off input can also reset the overload reduction circuit. When activated, "brake-on" provides maximum brake torque regardless of the signal from the control logic boards. The same is true of the brake off input, as this turns the brake fully off regardless of signal level.

The overload reduction circuit automatically reduces the current output to the brake from 500 ma. per magnet to 270 ma. per magnet after approximately 30 seconds when the control asks for operation in the 270 to 500 ma. range. In addition, an overload indicator illuminates on the front panel.

The driver board's anti-residual circuit applies a reverse current to the brake during the off portion of the output pulse or when the brake off input is activated. The reverse current supplied by the anti-residual circuit is adjustable via a potentiometer so that static residual magnetism can be eliminated in the brake.

The output driver board also has protection circuits. These include reverse polarity protection if the (+) and (-) input power connections are reversed, short circuit protection on the output stage, and power input fusing to protect against accidental shorts.

Indicator LED's provide a visual means of checking for input power, brake output, and overload status.

The brake is the electromechanical link in the system. It is electrically actuated, so increasing or decreasing the current to the magnets increases or decreases torque.

## TECHNICAL SPECIFICATIONS

### TCS-167 Power Supply

**Input Power:** 120 VAC or 240 VAC,  $\pm 10\%$ , 50/60 HZ, 1 Phase  
Switch selectable on board.

**Output:** Unregulated 9 VDC at 1 amps  
Unregulated 48 VDC at 3.2 amps continuous,  
6 amps intermittent, 1.6% duty cycle, 30 second  
on time.

**Ambient Temperature:** -20° F to +115° F (-29° C to +46° C)

**Fusing:** F1: 1A  
F2: 8A  
F3: 7A/120 VAC  
5A/240 VAC

**Note:** All fuses are 312AG, FA, 250V types.

**Protection:** Overvoltage protected on outputs

### TCS-210 Dancer Control Module

**Input Power:** 8-12 VDC at 1.5 amps, 48 VDC at 1.8 amps  
continuous, 6 amps intermittent, 1.6% duty cycle,  
30 second on time. (From TCS-167)

**Brake Output:** Pulse-width modulated, 0 to 270 ma. continuous,  
270 to 500 ma. intermittent, 1.6% duty cycle, 30  
second on time. Up to 12 Electro-Disc magnets  
load.

**Ambient Temperature:** -20° F to +115° F (-29° C to +46° C)

**Fusing:** F1: 1 amp fast-acting, 125 V, type 3AG  
F2: 7 amp fast-acting, 125 V, type 3AG

**Protection:** Internal short circuit protection on driver output  
stage. Reverse voltage protection on DC input  
power connections.

**Overload Cutback:** Reduces output current to 270 ma./magnet after  
30 seconds operation in the 270 ma. - 500 ma./  
magnet range. Reset by brake-off input or reduced  
demand, below 270 ma. for 30 seconds.

**Sensor Input:** MCS-605-1 or TCS-605-5 Pivot-Point Sensor

**Auxiliary Input:** Brake-On — Applies full output, 500 ma./magnet  
to the brake. Overrides all other inputs except  
brake-off. Active low.

Brake-Off — Removes brake current and applies  
anti-residual current, activates anti-drift, and re-  
sets overload detector. Active low.

Anti-Drift — Provides integrator reset function.  
Active low.

Switch inputs can be controlled by switch closure  
between input and DC Common or open collector,  
NPN transistor to DC Common.

**Switch or Transistor Rating:** 20 VDC minimum, 0.02 amps maximum rating.

**Adjustments:**  
**Front Panel:**

Dancer position — provides reference for setting  
dancer operating position.

Gain — controls overall system response based  
on change of dancer input signal.

**Internal:** Frequency: Adjusts pulse-width modulation fre-  
quency to reduce brake hum.

Anti-residual — Adjusts negative current in the  
brake magnets in the brake-off mode. Used to  
reduce residual magnetism.

Proportional Gain: via R32

Integrator Gain: via R24

Differentiator Gain: via R16

SW1: Differentiator Range Switch

**Note:** Internal P-I-D adjustments are covered in greater detail under  
System Start-up and Adjustment, pages 4-5.

## **TCS-220 Remote/Analog Control Module**

<b>Input Power:</b>	8 to 12 VDC at 1.5 amps, 48 VDC at 1.8 amps continuous, 6 amps intermittent, 1.6% duty cycle, 30 seconds on time. (Supplied by the TCS-167)
<b>Brake Output:</b>	Pulse-width modulated, 0 to 270 ma. continuous, 270 to 500 ma. intermittent, 1.6% duty cycle, 30 seconds on time. Up to 12 Electro-Disc magnets load.
<b>Ambient Temperature:</b>	-20° F to +115° F (-29° C to +46° C)
<b>Fuses:</b>	F1: 1 amp, fast-acting, 125 VAC, type 3AG F2: 7 amp, fast-acting, 125 VAC, type 3AG
<b>Protection:</b>	Internal short circuit protection on drive output stage. Reverse voltage protected on DC input power connections.
<b>Overload Cutback:</b>	Reduces maximum output current to 270 ma./magnet after approximately 30 seconds in the overcurrent range of 270 to 500 ma./magnet Reset by brake-off input switch or by removing overload demand for approximately 30 seconds.
<b>Control Inputs:</b>	Via terminal strip connections in control enclosure. Input connections dependent on type of control input (manual, remote, voltage source, or current loop) selected.
<b>Auxiliary Inputs:</b>	<b>Brake-On</b> — Applies full output current (500 ma./magnet) to the brake regardless of control input signal. Overrides all other control inputs except brake-off. Active low. <b>Brake-Off</b> — Removes brake current and applied anti-residual current regardless of control input signals. Also resets overload detector. Active low.

### **Adjustments:**

#### **Front Panel:**

**Zero Adjust:** Provides for adjustment of minimum input to correspond to minimum output level.

**Torque Adjust/Span:** Provides for manual torque adjust when control is operated in local torque adjust mode, or provides for span adjustment when control is operated in other input modes.

#### **Internal:**

**Frequency:** Adjusts pulse-width modulation frequency to reduce brake hum.

**Anti-Residual:** Adjusts negative current in the brake magnets in the brake-off mode to reduce residual magnetism.

**Note:** Internal adjustments are covered in more detail under System Start-up and Adjustment, pages 4-5.

### **Pivot-Point Sensors**

#### **MCS-605-1, TCS-605-5**

**Part Numbers:** MCS-605-1, 7330-448-002, single turn  
TCS-605-5, 7330-448-003, 5-turn

**Control Element:** Precision potentiometer, 1000 ohms, 2 watts, ± 5% tolerance

**Cable:** 15 ft. long, shielded, with connector

**General:** The tension sensor should be kept free from foreign material, dust, grease and oil.

**General: (control & Power Supply)** The control chassis must be considered NEMA 1 and should be kept clear of all areas where foreign material, dust, grease or oil might affect the operation of the control.

Control chassis should be electrically grounded.

Neither the sensor input terminals nor the brake wires are at ground potential and should be considered "floating" unless both sides of the AC input power to the TCS-167 are disconnected.

## **TENSION BRAKES**

Data and technical specifications for the Electro-Disc Tension Brake can be found in Warner Electric catalog, P-771.

For brake installation, see manual P-259.

For this reason, and to achieve the best possible results, we recommend that you check off each completed step in the space provided before proceeding to the next step.

### **Installation**

This Installation and Operating Manual was arranged for the systematic installation and start-up of your tension control system.

#### **Sample**



Check box after completion of each step.



Remove control logic assembly by loosening two (2) captive screws on the faceplate and slide the assembly out of its housing.

## Installation — Control Housing

Since the Warner Electric Tension Control System is offered in a variety of mounting styles, it is necessary to determine the configuration to be used.

Once the mounting configuration has been determined, follow the appropriate installation instructions for that type of mounting.

### A. Wall Mounting

1. Remove control logic assembly from the housing (if assembled) by loosening the two (2) captive screws on the housing, disconnecting the ribbon cable from the control logic board.
2. If the bottom entry conduit entrance is required, remove the rear L-shaped bracket which partially covers the entrance and discard. Reinsert the screws into the housing.
3. Using the dimensions shown in Figure 1, drill four (4) mounting holes using a 13/64" drill to provide clearance for #10 bolts.
4. Loosen the latches holding the two-part housing together and separate the two pieces. Latches are located on the inside top and bottom of the housing.

5. Apply the terminal strip wiring label supplied with the control logic to the PC Board as shown in Figures 2 and 3, page 8.  
CAUTION: Be sure to apply the label with the brake terminal markings on top. The label must be applied to the PC Board before wiring.

6. Mount the rear section of the housing to the mounting wall.  
The control is now ready to be wired. To complete the power supply installation, refer to the appropriate system wiring found later in this manual.

### B. Shelf Mounting

1. Remove the control logic assembly from the housing (if assembled) by loosening the two (2) captive screws on the front panel. Slide the assembly out of the housing, disconnecting the ribbon cable from the control logic board.
2. If the bottom-entry conduit entrance is required, remove the two (2) screws attaching the bracket to the housing. Rotate the bracket to face away from the housing and reinsert and tighten the two (2) screws.
3. Using the dimensions shown in Figure 1, page 7, drill four (4) mounting holes with a 13/64" drill to provide clearance for #10 bolts.

4. Loosen the latches holding the two-part housing together and operate the two pieces. Latches are located on the inside top and bottom of the housing.
5. Apply the terminal strip wiring label supplied with the control logic to the PC Board as shown in Figures 2 and 3, page 8.  
CAUTION: Be sure to apply the label with the brake terminal markings up. The label must be applied to the PC Board before wiring.
6. Loosely mount the rear section of the housing to the selected mounting shelf.

The control is now ready to be wired. To complete the power supply installation, refer to the appropriate system wiring found later in this manual.

### C. Panel Mounting

1. Using the dimensions shown in Figure 4, page 9, cut an opening 3-5/16" x 6-1/16" into the mounting panel.
2. Using the dimensions shown in Figure 4, page 9, drill the four (4) mounting holes using a 13/64" drill to provide clearance for the #10 mounting studs.
3. Remove the four (4) nuts on the panel mounting studs.
4. Slide the housing assembly into the mounting panel cut-out. Securely fasten the housing to the mounting panel with the four (4) nuts.

5. Apply the terminal strip wiring label supplied with the control logic to the housing panel near the terminal strip as shown in Figures 2 and 3, page 8.  
CAUTION: Be sure to apply the label with the brake terminal markings up. The label must be applied to the housing before wiring.

The control panel is now ready for wiring. To complete the power supply installation, refer to the appropriate system wiring found later in this manual.

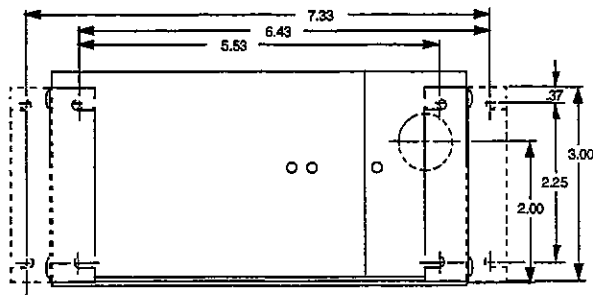

BOTTEM VIEW

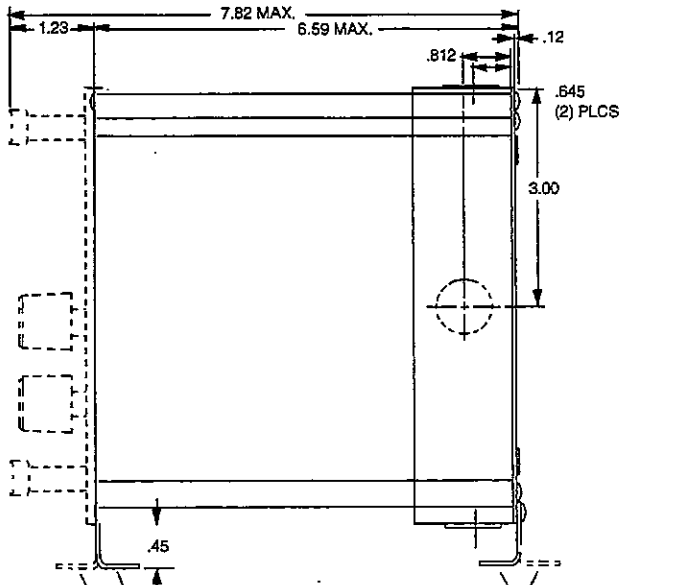

FRONT BRACKET MAY BE MOUNTED EITHER WAY AS SHOWN

BRACKET BASE MOUNT MAY BE MOUNTED EITHER WAY AS SHOWN FOR SHELVIE MOUNT REMOVED ENTIRELY FOR WALL MOUNT

SIDE VIEW

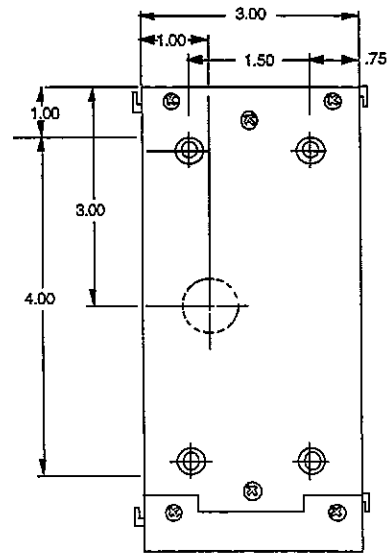

BACK VIEW

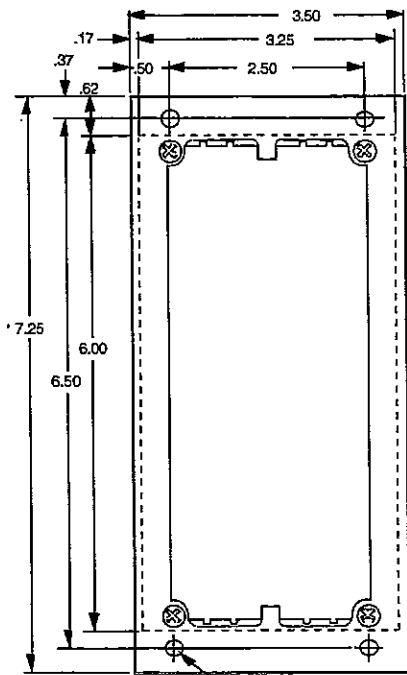

FRONT VIEW

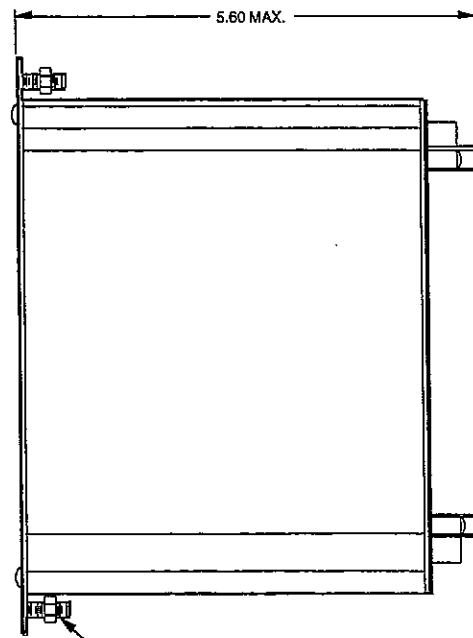

SIDE VIEW

Figure 1  
Mounting Dimensions, TCS-210 or TCS-220

P-261

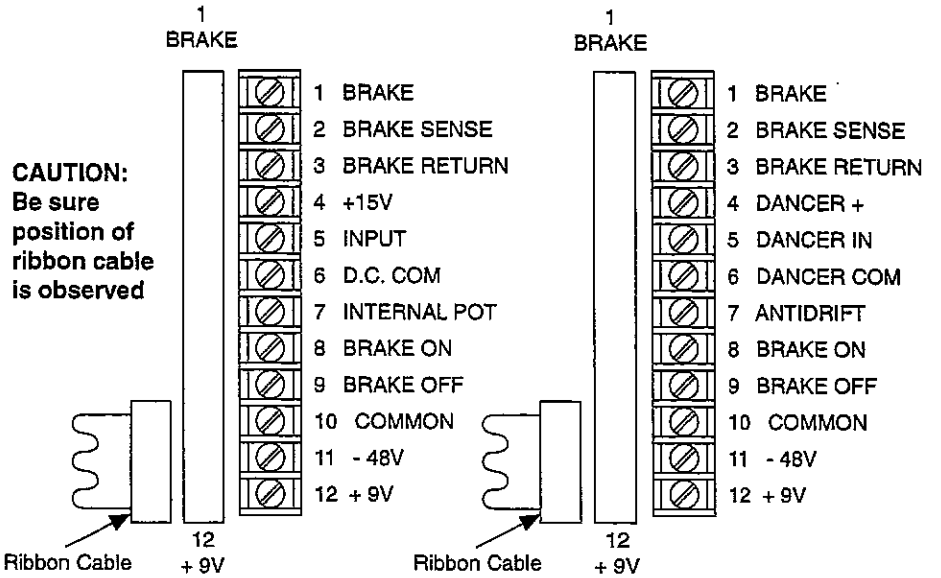
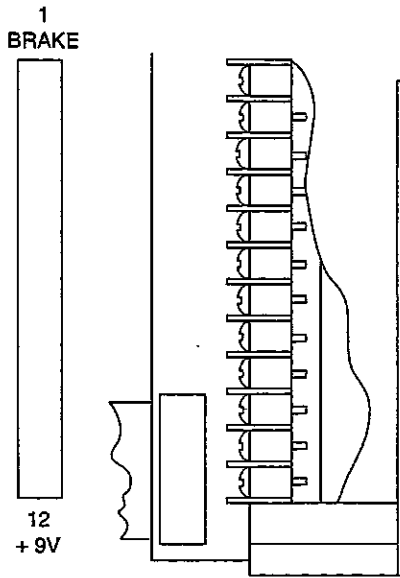

TCS-220

TCS-210

**Figure 2**  
TCS-210/TCS-220 W/S Label Orientation

**Figure 3**  
TCS-210/TCS-220 Panel Mount Label Orientation

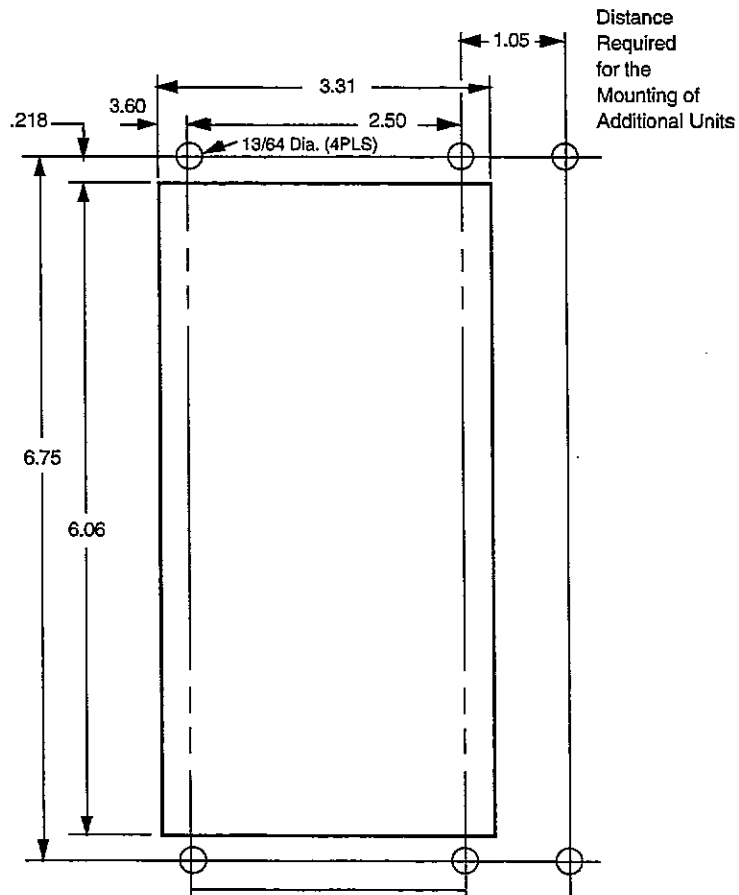

**Figure 4**  
TCS/220 Panel Mounting Dimensions & Cut-out



## TCS-167 POWER SUPPLY INSTALLATION

The TCS-167 can be mounted as an open frame or enclosed unit. For open frame mounting, the power supply chassis is affixed in the customer's panel or control enclosure. When used with the optional enclosure, the enclosure becomes the base plate for the power supply chassis, and only the enclosure is mounted to the machine frame.

### A. Open Frame Mounting

- 1. Select an appropriate mounting location in the panel with sufficient space for wiring access.
- 2. Using the dimensions shown in Figure 5, page 10, drill three (3) mounting holes using a 13/64" drill to provide clearance for #10 bolts.

NOTE: The TCS-167 is shipped bolted to a plywood base which must be removed before mounting.

- 3. Securely mount the TCS-167 to its panel using #10 bolts.

The power supply is now ready to be wired. Refer to the wiring section of the manual starting on page 10 for complete instructions.

### B. Optional Enclosure Mounting

- 1. Select an appropriate mounting location for the TCS-167 enclosure.

- 2. Using the dimensions shown in Figure 6, page 10, drill four (4) mounting holes using a 13/64" drill to provide clearance for #10 bolts.

- 3. Securely mount the enclosure in the selected location with #10 bolts.

NOTE: The TCS-167 is shipped bolted to a plywood base which must be removed prior to mounting in the enclosure.

- 4. Mount the TCS-167 power supply assembly using the mounting studs provided in the enclosure.

The power supply is now ready to be wired. Refer to the wiring section starting on page 14 of this manual for complete instructions.

### BRAKE INSTALLATION

Refer to manual P-259 for Brake Installation and Set-Up Procedures.

### MCS-605-1 PIVOT-POINT SENSOR INSTALLATION

The pivot-point sensor installation described in this section refers to the dancer system only with the sensor being mounted directly to the dancer arm pivot-point.

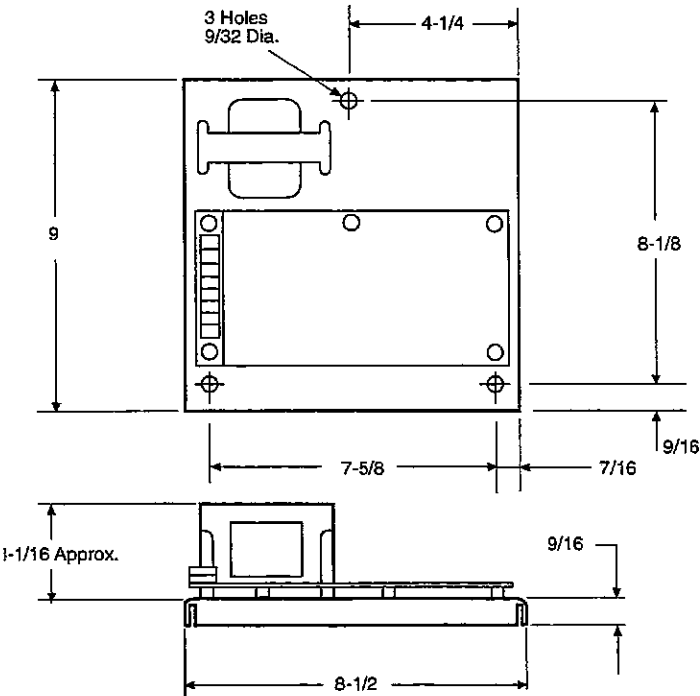

**Figure 5**

**TCS-167 Open Frame Mount Dimensions**

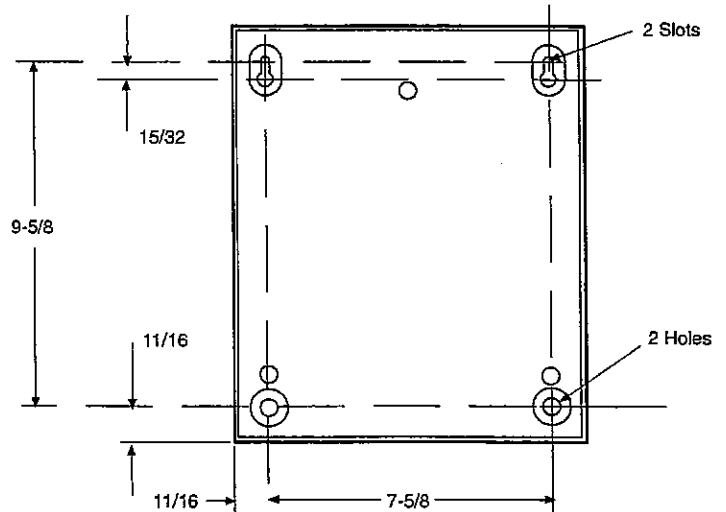

**Figure 6**

**TCS-167 Enclosure Mounting Dimensions**

# INSTALLATION INSTRUCTIONS

## MCS-605-1 Sensing Potentiometer

1. Using a No. 2 drill, drill a 1/2-inch deep hole in the center of the dancer pivot shaft.
2. Drive the supplied pin into the hole in the shaft until half its length remains exposed.
3. Assemble the two brackets supplied with the two 10-32 screws.
4. Mount the sensor to the brackets using the three 8-32 screws.
5. Position the sensor and bracket so that the sensor shaft and pin are aligned and separated by 5/16".
6. While holding the sensor and bracket in this position, mark the centers of the bracket holes on the machine.
7. Drill and tap three(3) holes for 8-32 screws in the machine.
8. Connect the sensor shaft to the pin with the supplied universal coupling. The index mark on the sensor shaft must be aligned with the index mark on the sensor face when the dancer arm is at the midpoint position.
9. Mount the sensor and bracket to the machine with three (3) 8-32 screws.
10. The sensor is now ready to be wired. Refer to the wiring section starting on page 14 of this manual for complete instructions.

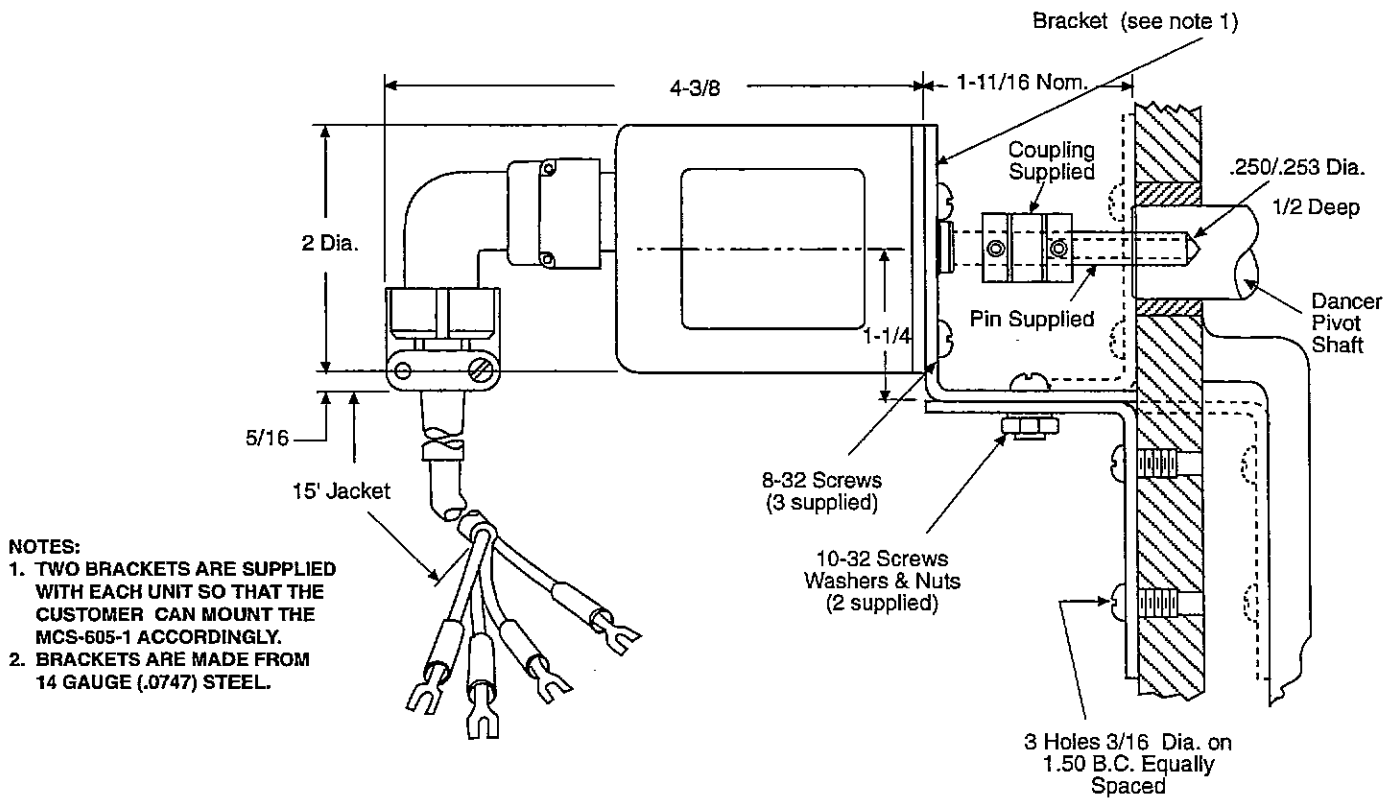

Figure 7  
MCS-605-1 Mounting Details

## SYSTEM WIRING PRECAUTIONS

These wiring precautions will help you properly install and wire a troublefree system.

1. Use a proper size wire gauge for the DC input and brake output current from the control circuits.
2. If possible, segregate wiring for DC power, brake output lines, input signal lines, and switch wiring.
3. Do not run AC power lines with DC power, brake output lines, input signal lines or switching lines as noise transients can be easily transferred, causing erratic control operation.
4. Use shielded cable when possible for connecting external sensors and switches to the controls.
5. Under no circumstances should auxiliary accessories be operated from the TCS-167, TCS-210, or TCS-220 controls.
6. Do not attempt to incorporate external switching schemes to switch between two or more brakes from a single TCS-210 or TCS-220 control. This will cause damage to the control and void the warranty.

## SYSTEM WIRING

### TCS-167 Power Supply Wiring

Refer to Figures 8 and 9 for actual wiring connections.

1. Wire AC neutral line to terminal 5 and tighten.
2. Wire AC hot line to terminal 6 and tighten.
3. Wire AC ground (green) to terminal 7 and tighten.
4. Connect an adequate length of wire to terminal 1 and tighten.
5. Connect an adequate length of wire to terminal 2 and tighten.
6. Connect an adequate length of wire to terminal 3 and tighten.

7. Connect an adequate length of wire to terminal 4 and tighten.
8. Set the 120/240 selector switch at the AC input voltage for which the power supply was wired.

NOTE: The wiring for terminals 1, 2, 3 and 4 should either be color coded for easy reference when wiring to the control modules, or have wire markers for identification.

**CAUTION: Do not apply power at this time unless power leads are wired to the control logic boards and the control logic is installed.**

### TCS-210 Wiring

Refer to Figure 8, page 13, for actual system wiring connections.

1. Connect current sense magnet (Puck #1) between terminals 2 and 3. Tighten terminal 2 only.
2. Connect the remaining brake magnets (Puck #2 through #12, if used) between terminals 1 and 3. Tighten both terminals.
3. Connect the +9V wire from TCS-167 power supply terminal 1 to terminal 12 and tighten.
4. Connect the -48V wire from TCS-167 power supply terminal 4 to terminal 11 and tighten.
5. Connect the 9V ground and 48V ground wires from TCS-167 power supply terminals 2 and 3 to terminal 10 and snug terminal 10 only.
6. Sensor connections
  - A. Determine the direction of the dancer arm rotation (CW or CCW) as the web length is shortened, when viewed from the connector end of the sensor.
  - B. If rotation is CW, connect the sensor as follows:
    1. Black lead to terminal 4 and tighten.
    2. Green lead to terminal 5 and tighten.

3. Red lead to terminal 6, do not tighten.
4. Shield lead to terminal 6 and tighten.
- C. If rotation is CCW, connect the sensor as follows:
  1. Red lead to terminal 4 and tighten.
  2. Green lead to terminal 5 and tighten.
  3. Black lead to terminal 6; do not tighten.
  4. Shield lead to terminal 6 and tighten.
7. External switch connections (optional)
  - A. Anti-drift or integrator reset switch. Connect switch or relay contacts between terminals 7 and 10. Tighten terminal 7 and snug terminal 10.

NOTE: The anti-drift switch should be a momentary contact closure of at least 50 milliseconds. This may be a limit switch sensing the dancer arm position or a one-shot relay contact actuated by the machine start cycle.

**CAUTION: This switch contact should be open when the system is in the running mode to prevent unpredictable reactions.**

- B. Brake-On Switch
 

Connect switch contacts between terminals 8 and 10. Tighten terminal 8 and snug terminal 10.

## TCS-210 Wiring (Cont.)

- C. Brake-Off Switch
- Connect switch contacts between terminals 9 and 10 and tighten both terminals.
- NOTE: If only a single brake-off or brake-on switch is used, it may be a single-pole, single throw, maintained contact type. If both functions are used, a three position switch as shown in Figure 8, page 13, is recommended.
8. Double check both the wiring connections per Figure 8 and the terminal connections. Insure that all terminals are tight.
9. If wall mounting was used, reconnect the two housings and secure the latches.

10. If shelf mounting was used, reconnect the two housings and secure the latches. Firmly secure the control housing to the mounting shelf with four (4) bolts.
11. Connect the ribbon cable to the logic control assembly and slide the control into the housing. Tighten the two (2) captive fasteners located on the faceplate, making sure the control is securely fastened to the housing.

**CAUTION: The faceplate of the control logic must be securely fastened to the control housing since the face plate and housing act as a heatsink for the output switching device.**

Proceed to the System Start-up and Adjustment section for the TCS-210, page 21.

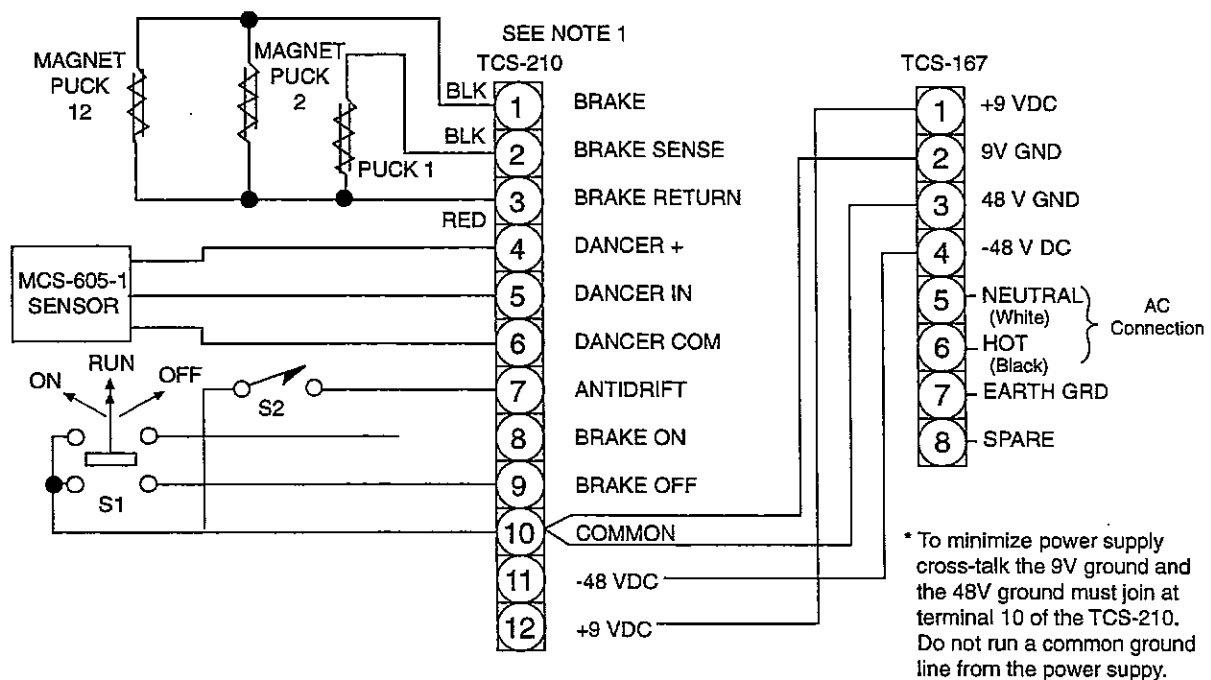

Figure 8 TCS-210 Wiring

1. Closing the switch S1 to the brake-off position will turn off the Electro-Disc brake, allowing the roll to freewheel during the initial threading of the web at set-up time. Brake-off overrides all other inputs. S1 also activates an internal antidrift switch (in parallel with S2) and also resets the overload detector.
2. When the brake-on switch S1 is in the on-position, full braking power will be applied to the tension brake, stopping the roll if a break should occur, or holding the roll stationary when replacing.
3. Momentarily closing the antidrift switch S2 at start-up allows the dancer to return to its normal running position with minimum overshoot and settling time.

\*1. Switches S1 and S2 should have 20 V, 20 ma. or greater rating.

\*2. Open collector NPN transistors may be substituted for S1 and S2. Transistors should have the following characteristics:  $V_{CE}$  breakdown  $\geq 20$  V,  $V_{CE SAT} \leq .7V$  at 20 ma. and offstate leakage  $\leq 10 \mu A$ .

## TCS-220 Wiring

Refer to Figures 9 and 10, pages 15 and 16, for actual system wiring and follow the sequential instructions below.

- 1. Connect the current sense magnet (Puck #1) between terminals 2 and 3. Tighten terminal 2 only.
- 2. Connect the remaining brake magnets (Pucks #2 through #12, if used) between terminals 1 and 3. Tighten both terminals.
- 3. Connect +9V wire from TCS-167 power supply terminal 1 to terminal 12 and tighten.
- 4. Connect -48V wire from TCS-167 power supply terminal 4 to terminal 11 and tighten.
- 5. Connect 9V ground and 48V ground from TCS-167 power supply terminals 2 and 3 to terminal 10. Snug terminal 10 only.
- 6. External switch connections (optional)
  - A. Brake-on switch  
Connect switch contacts between terminals 8 and 10. Tighten terminal 8 and snug 10.
  - B. Brake-off switch  
Connect switch contacts between terminals 9 and 10. Tighten both terminals.

NOTE: If only a single brake-off or brake-on switch is used, it may be a single-pole, single-throw, maintained contact type. If both functions are used, a three position switch as shown in Figure 9, page 15, is recommended.

### 7. Control input connections

Refer to Figure 10, page 16, for available input configurations.

#### A. Determine the type of input to be used.

- 1. Local torque adjust input —  
Leave jumper connected between terminals 5 and 7.
- 2. Remote torque adjust input —
  - a. Remove jumper from terminals 5 and 7.
  - b. Connect high side of potentiometer to terminal 4 and tighten.
  - c. Connect potentiometer wiper terminal to terminal 5 and tighten.
  - d. Connect low side of potentiometer to terminal 6 and tighten.

**CAUTION: Shielded cable is strongly recommended to connect the remote potentiometer and control input terminals to prevent pick-up of stray electrical noise. Connect the shield wire to terminal 6 at the control end only.**

#### 3. Current source input

- a. Determine the current range of the external source. (1.5 ma, 4-20 ma, or 10-50 ma)
- b. Select a shunt resistor for the appropriate current range from the chart in Figure 10, page 16.

- c. Install the shunt resistor between terminals 5 and 6. Snug terminals.
- d. Connect the positive (+) side of the current source to terminal 5 and tighten.
- e. Connect the negative (-) side of the current source to terminal 6 and tighten.

**CAUTION: Shielded cable is strongly recommended to connect the current source and the TCS-220 input to prevent pick-up of stray electrical noise. The shield wire should be connected to terminal 6 of the control only.**

#### 4. Voltage source input

**CAUTION: The maximum allowable input level from an external voltage source must not exceed 14.5 VDC. Voltage levels higher than 14.5 VDC will damage the control's input circuits.**

- a. Connect the positive (+) side of the voltage source to terminal 5 and tighten.
- b. Connect the negative (-) side of the voltage source to terminal 6 and tighten.

**CAUTION: Shielded cable is strongly recommended to connect the voltage source and the TCS-220 input to prevent pick-up of stray electrical noise. The shield wire should be connected to terminal 6 of the control only.**

#### 5. Roll follower input

##### a. Using MCS-605-1 pivot-point sensor —

- CCW  CW
- 1. Determine the direction of sensor shaft rotation as the roll diameter decreases when viewed from the connector end.
- 2. If the rotation is CW, connect the wires as follows:
  - (a) Connect black wire to terminal 4 and tighten.
  - (b) Connect green wire to terminal 5 and tighten.
  - (c) Connect red wire to terminal 6.
  - (d) Connect shield wire to terminal 6 and tighten.
- 3. If rotation is CCW, connect the wires as follows:
  - (a) Connect red wire to terminal 4 and tighten.
  - (b) Connect green wire to terminal 5 and tighten.
  - (c) Connect black wire to terminal 6.
  - (d) Connect shield wire to terminal 6 and tighten.

##### b. Using a potentiometer other than the MCS-605-1 —

- 1. Determine the direction of potentiometer rotation with relation to the roll follower arm.
- 2. Connect the wire from the wiper terminal to terminal 5 and tighten.
- 3. Determine the potentiometer terminal toward which the wiper rotates as the roll diameter decreases. Connect the wire from this terminal to terminal 6 and tighten.
- 4. Connect the remaining wire from the potentiometer to terminal 4 and tighten.

**CAUTION: Shielded cable is strongly recommended to connect the external pot and the TCS-220 input to prevent pick-up of stray electrical noise. The shield wire should be connected to terminal 6 of the control only.**

- 8. Double check all wiring connections per Figures 9 and 10, pages 15 and 16, as well as all terminal connections. Insure that all terminals are tight.
- 9. If wall mounting was used, reconnect the two housings and secure the latches.
- 10. If shelf mounting was used, reconnect the two housings and secure the latches. Firmly secure the control housing to the mounting shelf with four (4) bolts.

- 11. Connect the ribbon cable to the logic control into the housing. Tighten the two (2) captive fasteners located on the faceplate, making sure the control is securely fastened to the housing.

**CAUTION: The control logic faceplate must be securely fastened to the control housing since the faceplate and housing act as a heatsink for the output switching device.**

Proceed to the System Start-Up and Adjustment section for the TCS-220, page 25.

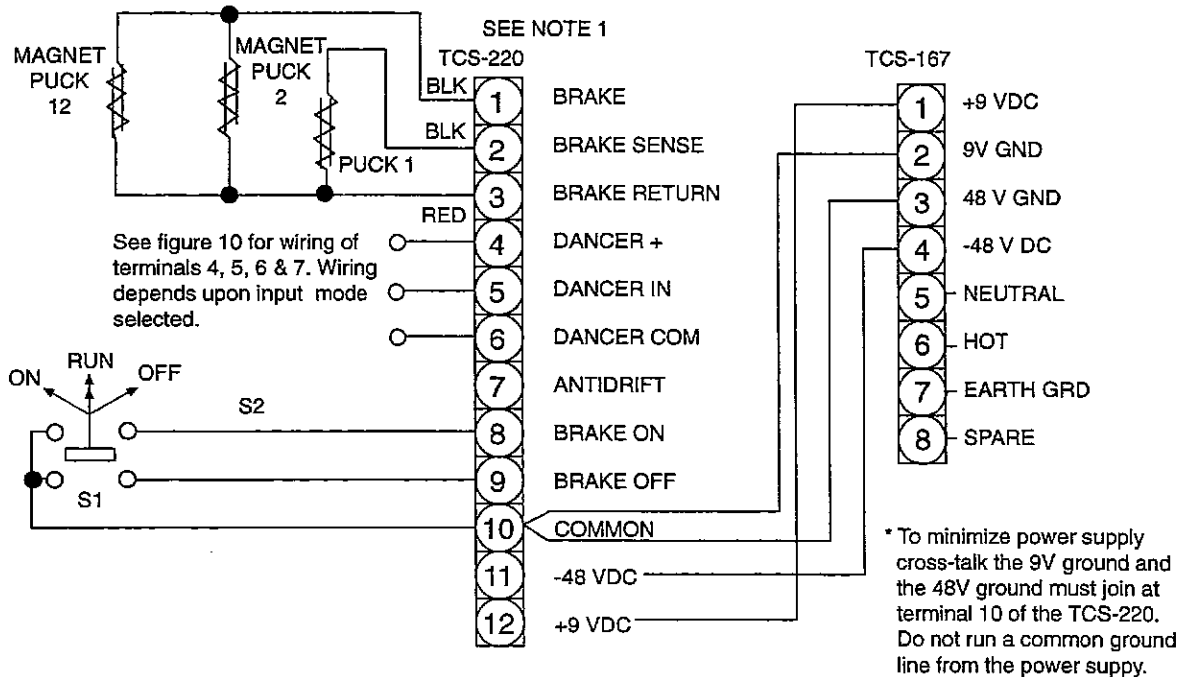

Figure 9 TCS-220 Wiring

1. Closing switch S1 in the off-position will turn off the tension brake, allowing the roll to freewheel during the initial threading of the web at set-up time. Brake-off overrides all other inputs. S1 also resets the overload detector.
2. When the brake-on switch S1 is in the on-position full braking power will be applied to the tension brake, thus stopping the roll if a break should occur, or holding the roll stationary when replacing.

**NOTES:**

- \*1. In multimagnet Electro Disc systems, puck 1 must be connected as shown for the system to work properly. With a single magnet Electro Disc, puck 1 is the only magnet and no connection to terminal 1 is required.
- \*2. Switch S1 should have 20 V, 20 ma. or greater rating.
- \*3. Open collector NPN transistors may be substituted for S1. Transistors should have the following characteristics:  $V_{CE}$  breakdown,  $\geq 20$  V,  $V_{CE SAT} \leq .7$  V at 20 ma. and offstate leakage  $\leq 10 \mu A$ .

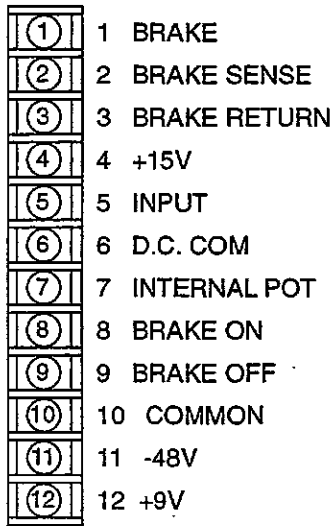

Figure 10A  
Terminal Block Label

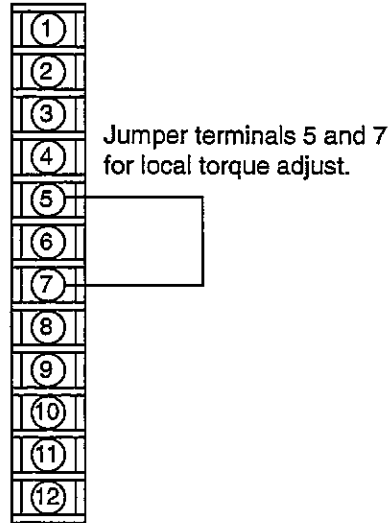

Figure 10B  
Local Torque Pot

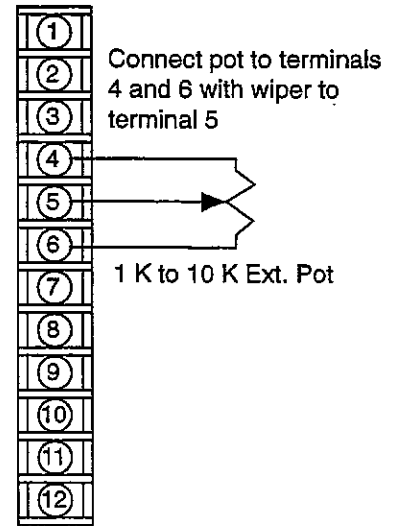

Figure 10C  
Remote Torque Pot  
or Roll Follower Input\*

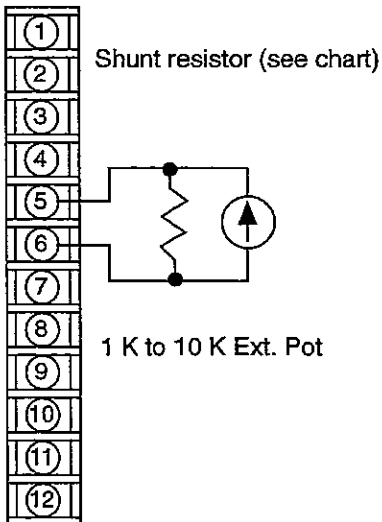

Figure 10D  
Current Loop Input\*

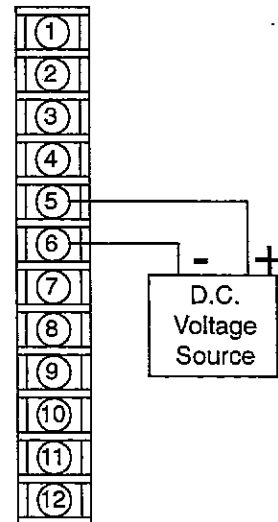

Figure 10E  
Ext. D.C. Voltage Input \*

### Shunt Resistor Range

Current Input	Min. $\Omega$	Max. $\Omega$
1-5 MA	470	1000 $\Omega$
4-20 MA	100	220 $\Omega$
10-50 MA	47 $\Omega$	100 $\Omega$

\* See set-up instructions for alignment.

P-261

# SYSTEM START-UP ADJUSTMENT

## TCS-167/TCS-210 DANCER SYSTEM

Most TCS-210 adjustments are set once and require no further attention. The exceptions are the "Dancer Position" and "Gain" controls on the front panel. The following adjustment procedures will produce a stable operating system.

Refer to Figure 11, page 19, for the exact location of the internal adjustment potentiometers.

### A. Static Adjustment

1. Apply power to the tension control system with the machine off. The "LED" marked "Power" on the TCS-210 should be illuminated.
2. Adjust the front panel "Dancer Position" knob to its midpoint setting.
3. Set the front panel "Gain" on "5."
4. Preliminary control check-out.
  - a. Position the dancer for the shortest possible web loop. Note that the brake "LED" goes off.
  - b. Position the dancer for the longest possible web loop. Note that the brake "LED" goes on.

NOTE: If steps 4a and 4b are reversed, the MCS-605-1 sensor is wired backwards. Refer to the wiring section for correct connection.

5. Brake-on/brake-off switch check-out (optional)
  - a. Activate the brake-off switch. Note that the brake LED goes off.
  - b. Return the brake-off switch to its normal run position.
  - c. Activate the brake-on switch. Note that the brake LED goes on.
  - d. Leave the brake on switch activated for 1 minute. Note that after approximately 30 seconds the overload LED illuminates.
  - e. Return the brake-on switch to its normal running mode. Momentarily activate the brake-off to reset the overload circuit.

NOTE: If operation of the brake-on/brake-off switches produced the opposite results in 5a and 5c above, the wiring is reversed. Refer to the wiring section for proper connection.

6. Antiresidual adjustment (method 1)
  - a. Activate the brake-off switch (if used) or move the dancer to the shortest web loop.
  - b. Check that the brake magnets release, allowing the armature to rotate freely.
  - c. Reapply the brake by returning the brake-off switch to its normal run position and activate the brake-on switch (if used) or reapply the brake by moving the dancer to the longest web loop.

- d. Repeat steps 6a through 6c above, verifying that the brake does release.
- e. If the brake releases, make no further adjustments. If the brake fails to release, proceed to step f.
- f. Adjust the antiresidual potentiometer CCW or CW until the magnet(s) releases.
- g. Repeat steps a. through c., and f. until optimum release is obtained.

NOTE: CCW adjustment decreases the antiresidual output while CW adjustment increases it. If the antiresidual is adjusted too far CW, brake engagement may occur.

7. Optional antiresidual adjustment (method 2)
  - a. Turn off power to the TCS-167/TCS-210 system.
  - b. Insert a current meter (preferably digital) in series between the current sense magnet and terminal 2 of the control.
  - c. Reapply power to the system.
  - d. Release the brake by activating the brake-off switch (if used) or moving the dancer to produce the shortest web loop.
  - e. Measure the antiresidual current to the brake magnet. Current should be in the following ranges:  
Cast armature: -35 to -40 ma.  
Steel armature: -10 to -12 ma.
  - f. Adjust the antiresidual potentiometer to obtain the proper current. See Figure 11, page 19.
  - g. Check to insure that the brake magnet releases and the armature rotates freely.
  - h. Return the brake-off switch to its normal running position and shut off AC power to the system.
  - i. Disconnect the meter and reconnect the magnet lead.
  - j. Reapply power to the system.

### 8. Frequency adjustment

Adjust the frequency potentiometer CW if a low pitched hum is noticeable, or CCW if a high pitched hum is noticeable.

NOTE: Frequency adjustment is factory set and normally requires no adjustment. If the brake "hums" or "howls" in the static mode, the frequency potentiometer should be adjusted to minimize the audible range.

### B. Start-Up and Dynamic Adjustment

1. Verify that system power is still on.
2. Start the machine and draw the web.
3. After the dancer has stabilized, adjust the front panel "Dancer Position" potentiometer for the desired dancer running position.



4. If the system operation is stable, increase the front panel "Gain" until hunting or oscillation occurs. Once this point is found, reduce the gain until the system stabilizes. Note the gain position where this occurs.
5. Reduce the gain an additional one (1) to two (2) numbers below the setting obtained in Step 4.
6. If the dancer is unstable from the start, reduce the gain until it becomes stable.

NOTE: This is only a preliminary gain setting. Final gain adjustment is accomplished in steps 7 and 8 below.

7. Allow the system to run until the unwind roll is within two to four inches of the core.
8. If the system is stable, adjust the front panel "Gain" until instability or oscillation occurs. Reduce the gain from this setting until stability is obtained, noting the gain setting. Reduce an additional one to two numbers below this point.

NOTE: This is the optimum gain setting. No further adjustments should be necessary.

### C. P-I-D Adjustments

**CAUTION: Internal P-I-D gain adjustments should be made only after all other attempts to achieve system stability have failed. These adjustments should be made by qualified personnel only.**

NOTE: Internal access is required for the set-up adjustments which follow. This can be accomplished with the TCS-900 set-up and diagnostic tester or by removing the side panel plate from the housing, or, by sliding the control module partially out of the housing.

**CAUTION: If side panel plate on the control housing is to be removed, insure the power is off before removing the control module from the housing. Failure to disengage power before removing the module will result in damage to the control and/or power module.**

**IMPORTANT: Follow the sequences outlined below to properly adjust the P-I-D circuit gains. If the TCS-900 is used, follow the instructions included with the TCS-900.**

1. "P" - Proportional gain adjustment, R32
  - a. Jumper the anti-drift input (terminal 8) to DC common (terminal 9) on the TCS-203 terminal block to disable the integrator circuit.
  - b. Inject a transient into the system by rapidly changing the dancer position. Suddenly changing dancer air pressure or rapidly depressing the web or dancer arm will provide the transient. Observe the dancer's response.
  - c. The dancer should stabilize within one to two cycles. If oscillations do not subside, reduce the "P" gain potentiometer, R32, CCW in small increments, observing the effects.
  - d. Repeat steps b. and c. above as necessary until desired response is obtained.

NOTE: "P" gain settings are a function of brake size, R32 is factory set at 100% CW. Generally, the larger the brake, the lower the R32 setting.

NOTE: If response is not obtained with "P" gain adjustment, it may be necessary to make "D" gain adjustments as well.

2. "D" - Differentiator gain adjustment, R16

- a. Insure anti-drift (terminal 8) is still grounded.
- b. Inject a transient into the web as described in step 1b above.
- c. If dancer stability is achieved within one or two cycles, make no further adjustments.
- d. If stability is not achieved, adjust R16 as follows:
  1. If response is erratic and dancer is extremely jerky, rotate R16 CCW.
  2. If response is sluggish and dancer hunts, rotate R16 CCW.

NOTE: If proper response is not achieved with R16 at maximum CW setting, the next higher differentiator response range should be used.

**CAUTION: When switching to higher response ranges, R16 should be set full CCW.**

- e. Repeat steps b. through d. above to insure optimum response.
- NOTE: To insure optimum performance, the system should be checked at or near full roll diameter.
- f. Remove jumper on anti-drift input (connecting terminal to DC common terminal 9).
  3. "I" - Integrator gain adjustment, R24.

**CAUTION: The "I" gain adjustment controls how far the dancer must move to compensate for unwind roll diameter changes. Any adjustment must be made strictly in accordance with the instructions below:**

- a. With the system running and stabilized, observe the amount of dancer movement.
- b. If the dancer arc is less than 5 degrees and movement is smooth, do not make any adjustments.
- c. If dancer arc is greater than 10 degrees, but movement is smooth, adjust the "I" gain potentiometer CW in small increments, observing the results, until stability is achieved.
- d. If dancer arc is within 5 to 10 degrees, but movement is choppy and rough, adjust the "I" gain potentiometer CCW in small increments, observing the results, until stability is obtained.
4. After completing P-I-D adjustments, recheck main gain adjustments per steps C4 through C8.

This completes the start-up and adjustment procedure for the TCS-167/ TCS-210 dancer control system.

If any difficulties encountered cannot be resolved through this start-up and adjustment procedure, contact your local Warner Market Representative.

The TCS-210 front panel knobs can be removed to prevent tampering with adjustments. Follow the procedure below:

1. Insert a screwdriver blade between the front panel and the knob and gently pry off one or both knobs.
2. Insert plastic hole plugs (if desired) to prevent unauthorized adjustment.

### General Notes on TCS-210 Operation

1. The overload "LED" will illuminate whenever the output is operated in the current range of 270 ma. to 500 ma. for more than 30 seconds.
2. The overload "LED" can be reset by activating the brake-off input or by reducing the output demand below 270 ma. for approximately 30 seconds.
3. During the stop cycle of the machine, the overload "LED" may

illuminate if the dancer has dropped below its midpoint, causing the integrator to ask for maximum output. After 30 seconds the overload "LED" will illuminate.

- The output short circuit protection scheme can be activated by either

a short in the magnets or by a severely high transient feed back through the brake lines. No single visual indicator shows that this circuit has been activated. Rather, the power and overload front panel indicator LED's may be on, but the brake "LED" will be off. To reset the short circuit protection device, a power down cycle is required.

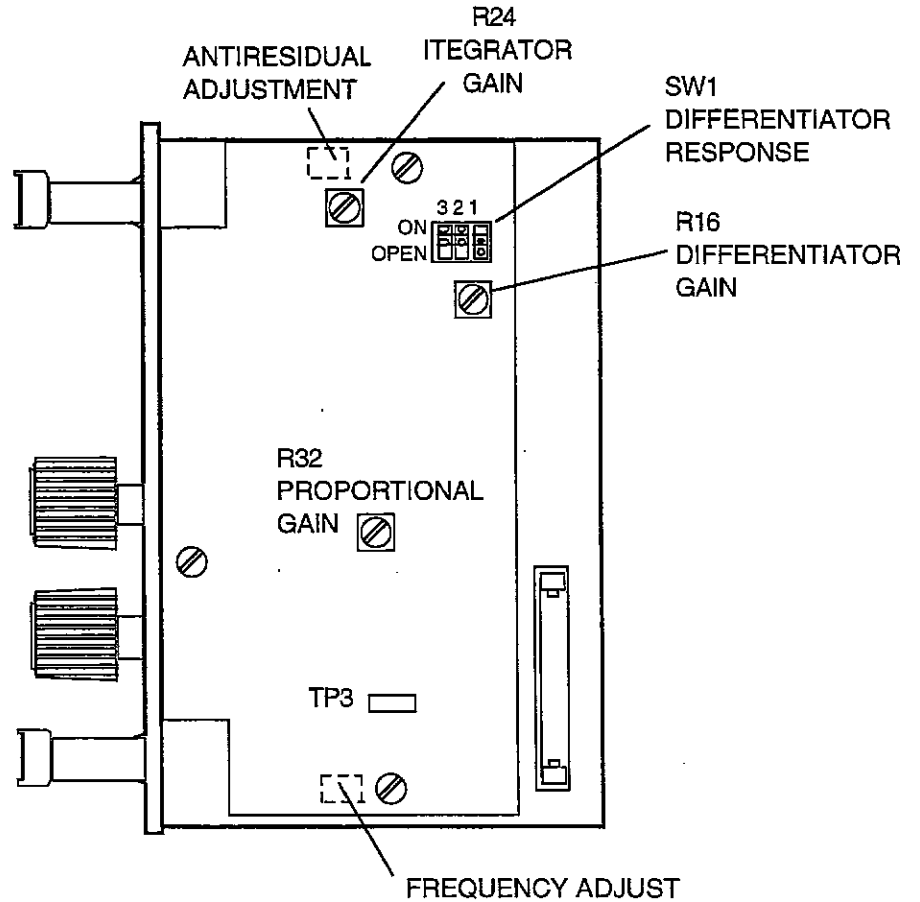
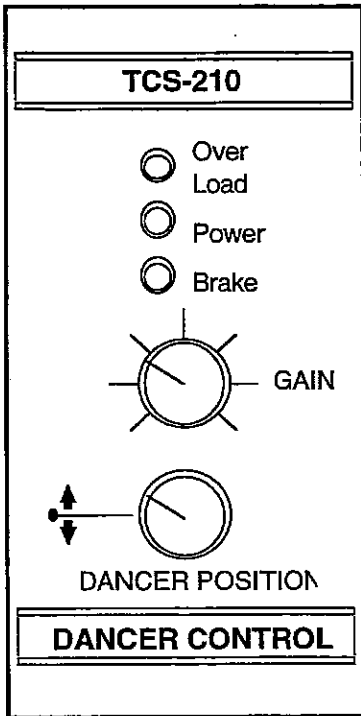

Figure 11 TCS-210 Adjustments

## TCS-167/TCS-220 REMOTE/ANALOG SYSTEM

Refer to Figure 12, page 22, for control adjustment locations on the TCS-220.

### A. Static Adjustments

1. Apply power to the tension control system with the machine off. The "LED" marked power on the TCS-220 panel should be illuminated.
2. Adjust the front panel "Torque/Span" potentiometer to its full CCW setting.
3. Brake-on/brake-off switch check-out (optional)
  - a. Activate the brake-off switch. Note the brake "LED" is off and the brake armature freewheels.
  - b. Return the brake-off switch to its normal run position.
  - c. Activate the brake-on switch, if used. Note that the brake "LED" illuminates fully.
  - d. Leave the brake-on switch activated for one minute. After approximately 30 seconds the overload "LED" illuminates.
  - e. Return the brake-on switch to its normal run position. To reset the overload "LED," momentarily activate the brake-off switch.

NOTE: If brake-on/brake-off switch operation produces results opposite from 3a and 3c above, the switch wiring is reversed. Refer to the wiring section for proper wiring.

4. Antiresidual adjustment (method 1)
  - a. Activate the brake-off switch, if used, or jumper terminals 9 and 10.
  - b. Check that the brake magnets release, allowing the armature to rotate freely.
  - c. Reapply the brake by returning the brake-off switch to its normal run mode, or remove the jumper between terminals 9 and 10.
  - d. Activate the brake-on switch, if used, or jumper terminals 8 and 10, to fully apply the brake.
  - e. Repeat Steps a. through c., verifying that the brake releases each time.
  - f. If the brake releases, make no further adjustments. If the brake does not release, proceed to Step g.
  - g. Adjust the antiresidual potentiometer CCW or CW until the brake magnets release.
  - h. Repeat Steps a. through d., and g., until optimum magnet release is obtained.

NOTE: CCW adjustment decreases the antiresidual output while CW adjustment increases output. If the antiresidual pot is adjusted fully CW, brake engagement may occur.

5. Optional antiresidual adjustment (method 2).
  - a. Remove power from the TCS-167/TCS-220 system.
  - b. Insert a current meter (preferably digital) in series with the current sense magnet and TCS-220 control terminal 2.
  - c. Reapply power to the system.
  - d. Activate the brake-off switch, if used, or jumper terminals 9 and 10 to fully release the brake.

- e. Measure the antiresidual current to the brake magnet. Current should be in the following ranges:

Cast Armatures: -35 to -40 ma.  
Steel Armatures: -10 to -12 ma.

- f. If necessary, adjust the antiresidual potentiometer to obtain the proper current.
  - g. Check to insure that the brake magnets release and the armature rotates freely.
  - h. Return the brake-off switch to its normal run position or remove the jumper from terminals 9 and 10. Turn the system AC power off.
  - i. Disconnect the current meter and reconnect the magnet lead to terminal 2.
  - j. Reapply power to the system.
6. Frequency adjustment
    - a. Adjust the frequency potentiometer CW if a low pitched hum is noticeable, or CCW if a high pitched hum is noticeable. Adjust until the hum is least noticeable.

NOTE: The frequency is factory set and normally requires no adjustment.

### B. System Adjustments

NOTE: Except for the roll follower system, determine if the maximum input level corresponds to the continuous output rating of 270 ma./magnet or the intermittent output rating of 500 ma./magnet.

1. If adjustments for maximum input signal level are to correspond to 270 ma./magnet output, then the control adjustments **must** be made with the overload "LED" on. The overload can be activated with the brake-on switch, if used, or by jumpering terminals 8 and 10 for 1 minute or longer. Repeat as necessary to maintain the overload LED on.
2. If adjustments for maximum input signal level are to correspond to 500 ma./magnet output, then the control adjustments **must** be made with the overload LED off. If the overload LED does illuminate when adjusting, it can be reset by activating the brake-off switch, if used, or by momentarily jumpering terminals 9 and 10.
3. Determine the input signal mode to be used and proceed to the proper set-up adjustments.
4. Local torque adjust.

NOTE: The TCS-220 is factory adjusted to operate in the local torque mode for a range of 0 to 270 ma./magnet output. If adjustment is necessary, follow this procedure:

- a. Connect a DC voltmeter capable of measuring +67 VDC to -5 VDC between terminals 2 and 3 of the TCS-220. Connect the positive (+) lead to terminal 2 and the negative (-) lead to terminal 3.
- b. Set the "Torque/Span" pot to its maximum CW position.
- c. Turn the "Zero Adj." potentiometer (through the front panel) CW until the output level across the brake magnet is at, or slightly below, the maximum output setting. **DO NOT ADJUST BELOW THIS POINT.**
- d. Set the "Torque/Span" fully CCW.

- e. Observe that the output voltage across the brake magnet registers negative.
  - f. Repeat Steps b. through f. as necessary to obtain optimum settings.
  - g. Using the "Torque/Span" adjust, set the desired brake output level. CW increases brake torque, while CCW decreases brake torque.
  - h. Remove the voltmeter from terminals 2 and 3.
5. Remote torque adjust.
- a. Connect a DC voltmeter capable of measuring +67 V to -5 VDC between terminals 2 and 3 of the TCS-220. Connect the positive (+) lead to terminal 2 and the negative (-) lead to terminal 3.
  - b. Set the remote potentiometer to its maximum CW setting.
  - c. Set the "Torque/Span" adjust for maximum brake output voltage as indicated by the meter.
  - d. Set the remote potentiometer for fully CCW.
  - e. Set the "Zero Adj." potentiometer for full antiresidual output as indicated by maximum negative voltage on the meter.
  - f. Repeat Steps b. through e. as necessary until the adjustment in c. has no effect on the adjustment in e. and vice versa.
  - g. The remote potentiometer now adjusts the brake output level. CW rotation should increase brake torque while CCW rotation should decrease brake torque.
  - h. Remove the meter from terminals 2 and 3.
6. Current source adjust
- a. Connect a DC voltmeter capable of measuring +67 VDC to -5 VDC between terminals 2 and 3 of the TCS-220. Connect the positive (+) lead to terminal 2 and the negative (-) lead to terminal 3.
  - b. Verify that the correct shunt resistor was selected for the input current range from the chart in Figure 10, page 16.
  - c. Set the current source for maximum input.
  - d. Set the "Torque/Span" adjustment for maximum output voltage across the brake as indicated by the meter.
  - e. Set the current source for minimum input.
  - f. Set the "Zero-Adj." to provide maximum antiresidual output as indicated by the negative voltage on the meter.
  - g. Repeat Steps c. through f. until the adjustment in d. has no effect on the adjustment in f. and vice versa.
  - h. Remove the meter from terminals 2 and 3.

NOTE: Set-up adjustments are the same for the control's three current ranges.

#### 7. Voltage source adjust

**CAUTION:** The maximum input voltage supplied by the external source cannot exceed 14.5 VDC. If voltages above 14.5 VDC are applied to the input, damage will result.

- a. Connect a DC voltmeter capable of +67 VDC to -5 VDC between terminals 2 and 3 of the TCS-220. Connect the positive (+) lead to terminal 2 and the negative (-) lead to terminal 3.
  - b. Set the external voltage source for maximum input.
  - c. Set the "Torque/Span" adjustment for maximum output voltage across the brake as indicated by the meter.
  - d. Set the external voltage source for minimum input.
  - e. Set the "Zero Adj." to provide maximum antiresidual output as indicated by negative voltage on the meter.
  - f. Repeat Steps b. through c. until adjustment in Step c. has no effect on adjustment in Step e. and vice versa.
  - g. Remove the meter from terminals 2 and 3.
8. Roll Follower Input
- a. Connect a voltmeter capable of +20 VDC between terminals 5 and 6 on the TCS-220. Connect the positive (+) lead to terminal 5 and the negative (-) lead to terminal 6.
  - b. Adjust the roll follower arm for a true zero position which corresponds to the exact center of the roll shaft. Input voltage should be 0.5 VDC to 1.0 VDC. If the voltage is not within this range, readjust the potentiometer to provide this range.
  - c. Remove the meter from terminals 5 and 6. Reset the meter to measure from +67 V to -5 VDC and connect the positive (+) lead to terminal 2 and the negative (-) lead to terminal 3.
  - d. Set the roll follower arm to correspond to the maximum roll diameter.
  - e. Set the "Torque/Span" adjust to provide the desired brake output level as indicated by the meter.
  - f. Set the roll follower arm for the true zero position of the unwind shaft.
  - g. Set the "Zero Adj." to provide maximum antiresidual output as indicated by negative voltage on the meter.
  - h. Repeat Steps h. through g. until the adjustment in Step e. has no effect on the adjustment in Step g. and vice versa.
  - i. Remove the meter from terminals 2 and 3.

NOTE: The TCS-220 output should be set for the desired tension at maximum roll diameter. Depending on required torque levels, the output voltage may not be a maximum.

This completes the start-up and adjustment procedure for the TCS-167/ TCS-220 remote/analog control system.

If any difficulties encountered cannot be resolved through this start-up and adjustment procedure, contact your local Warner Electric Market Representative.

With the exception of the local torque adjust and roll follower modes, the front panel "Torque/Span" knob should be removed and the hole plug inserted.

## GENERAL NOTES ON TCS-220 OPERATION

1. The overload "LED" will illuminate whenever the output is operated in the current range of 270 ma. to 500 ma./magnet for more than 30 seconds.
2. The overload "LED" can be reset by activating the brake-off input or by reducing the output demand below 270 ma./magnet for approximately 30 seconds.
3. The output short-circuit protection scheme can be activated by either a short in the magnets or by a severely high transient fed back through the brake lines. No single visual indicator shows when this circuit has been activated. Rather, the power and overload front panel indicator "LED's" may be on. To reset the short circuit protection, a power down cycle is required.

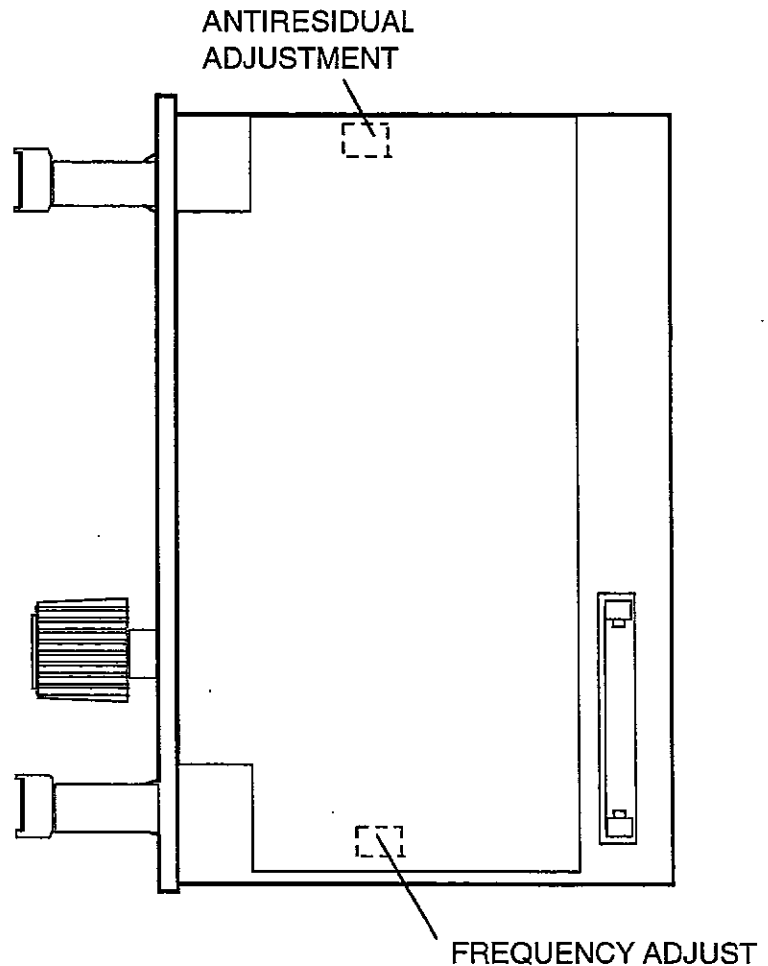
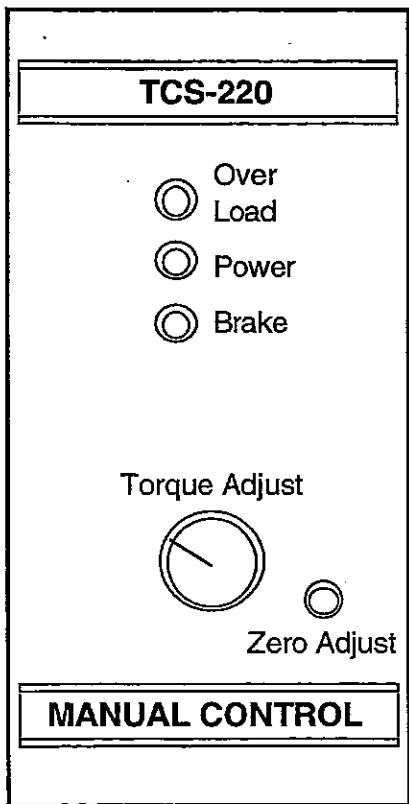

Figure 12  
TCS-220 Adjustments

**TROUBLESHOOTING**  
**APPLIES TO TCS-210 CONTROL, TCS-167 POWER SUPPLY,**  
**AND MCS-605-1 PIVOT-POINT SENSOR**

**General:** The chart below will be helpful when isolating exact problems which may occur in the control system. The chart will also prove helpful when encountering problems with the initial start-up of the system. When the system has been running for some time, the chart will also be helpful when checking for worn, broken or frayed wires; bent or broken control system parts; blown fuses; loose terminal connections and wire connections; loose or broken sensor couplings; worn or loose mechanical parts for the tension stand (bearing, couplings, etc.); and dust or dirt accumulation inside the control which has caused components to overheat.

**Symptom A: Dancer will not raise from bottom position**

Problem Cause	Suggested Solution
Incorrect Dancer Position setting.	Adjust Dancer Position setting until dancer moves to normal running position.
Dancer is not free to move because of obstruction.	Remove obstruction, release any holding devices or safety locks.
No DC power to the control.	Check for input LED illumination on TCS-210. Check for output LED illumination on TCS-167. Check fuses. Check proper DC input connections to control (refer to tension control hookup instructions). Check AC power input to TCS-167 if used.
Brake is not engaging.	Check to be sure lead wires to the brake are at the brake terminals and at terminals 1, 2 and 3 of the control. Check to see if sensor is connected. Using a voltmeter, check for approximately +6 to -67 volts DC between the brake terminals. If there is no voltage, check for approximately +6 to -67 volts DC between terminals 1 and 3 on the control. If the voltage is present at the control and not at the brake, wires to the brake are open. If there is no voltage at terminals 1 and 3 of the control, replace the printed circuit board assembly. If there is voltage at the brake terminal, check the brake coil resistance with an ohmmeter for shorted brake puck. Check for proper pivot sensor alignment. Check to see that brake is wired properly. Check to see that Brake Off input is not activated.
Brake does not have the torque capacity required for the application.	Verify that the correct brake was selected by repeating the selection procedure.

**Symptom B: Dancer moves to and remains at upper limit during initial systems start-up.**

NOTE: Refer to symptom C if dancer moved to upper limit after it had been running normally at the proper position.

Problem Cause	Suggested Solution
Incorrect Dancer Position setting.	Adjust Dancer Position setting until dancer moves to normal running position.
Roll shaft not free to rotate with control off.	Brake and shaft must be free to rotate with control off.
Sensor incorrectly connected to control terminals.	Verify sensor connections.
Is output LED off?	Using a voltmeter, check the DC voltage at the brake terminals as follows: Slowly raise the dancer and observe that the voltage decreases—then slowly lower the dancer and observe that the voltage increases. If the voltage indications are the opposite, reverse the sensor leads at terminals 5 and 7 of the control (see Sensor Wiring). If no voltage change occurs, check sensor cable connections (check pivot point coupling connection if MCS-605-1 sensor is used). If no voltage change occurs, be sure that the brake wires are not grounded to machine.

*P-201*

Brake is not releasing as dancer is raised (even though voltage decreases).

Check the mechanical parts of the brake to assure they are in good operating condition and properly installed. Check to see if Brake On input is activated.

**Symptom C: Dancer moves to and remains at upper limit after operating in a normal running position for a period of time.**

<b>Problem Cause</b>	<b>Suggested Solution</b>
Incorrect Dancer Position setting.	Adjust Dancer Position setting until dancer moves to normal running position.
Dancer pivot point sensor coupling has slipped.	If dancer position adjustment lowers the arm near its normal running position, realign pivot point sensor (see Sensor Mounting).
Faulty P.C. Board	With "dancer position" and "dancer stability" at minimum setting, check that the voltage on the brake terminal reduces to less than two volts as the dancer arm is raised. If voltage does not reduce to less than two volts, replace printed circuit board assembly.
(Problem occurs near roll core only!) Residual torque of the unwind stand exceeds the minimum torque allowable for the application.	With dancer position and dancer stability at minimum settings, check that the DC voltage at the brake terminals reduces to 0 and reverses polarity as the dancer arm is slowly raised. If the voltage reduces and reverses polarity, check to be sure that the brake is in good operating condition and properly installed (see tension brake maintenance-torque loss). Also check to be sure that the unwind stand friction is not excessive for the application. Check the brake selection procedure to be sure the brake being used does not exceed the minimum allowable torques. If the voltage did reduce to zero but did not reverse polarity, adjustment of the antiresidual may be necessary. If adjustment of the antiresidual does not cause the brake voltage to reverse polarity in the off state, replace the PC Board Assembly.

**Symptom D: Dancer moves erratically—appears to hunt or oscillate.**

<b>Problem Cause</b>	<b>Suggested Solution</b>
Incorrect Dancer Gain setting.	Adjust Dancer Gain setting CCW until dancer stops hunting.
Nonuniform system friction.	If the hunting coincides with revolution of the web parent roll, check faulty bearings or mismounted brake.
Improperly installed sensor.	When an MCS-605-1 Sensor is being used, check to be sure the index mark on the sensor shaft is aligned with the index mark on the sensor body when the dancer is at the mid-travel position. Also, be sure there is no lag between the movement of the dancer pivot point and the shaft of the sensor—the sensor shaft must move when the dancer pivot moves (refer to the Sensor Mounting section).
Loose or faulty sensor and cable assembly.	Check to be sure that all connections to the control terminal block and the brake wire connections are secure. Check electrical connector at sensor to be sure it is not loose. Using a DC voltmeter connected between control terminals 5 and 6, check to be sure the voltage variation is smooth as the dancer is slowly moved through its travel limits. If the voltage variation is not relatively smooth, either the sensor or cable assembly is faulty. To isolate the fault to the cable or the sensor, disconnect the cable from the sensor and connect an ohmmeter between the middle pin and one of the remaining pins on the sensor receptable. The resistance indication should vary smoothly as the dancer is moved through its travel limits. If the indication is erratic, the sensor should be replaced; if the indication is not erratic, the cable assembly should be replaced. If above steps seem normal, recheck dancer arm length (most applications require a dancer arm at least 12" long).

## TROUBLESHOOTING TENSION CONTROL SYSTEM REMOTE/ANALOG CONTROL

With the exception of the dancer input, general TCS-167/TCS-220 system troubleshooting is quite similar to the TCS-167/TCS-210. The chart below will be helpful in isolating problem causes.

Problem Cause	Suggested Solution
No DC power to the control.	<p>Check for input LED illumination on TCS-220.            Check for output LED illumination on TCS-167.            Check fuses.            Check proper DC input connections to control (refer to tension control hookup instructions).            Check AC power input to TCS-167 if used.</p>
Brake is not engaging.	<p>Check to be sure lead wires to the brake are at the brake terminals and at terminals 1, 2 and 3 of the control.            Check to see if sensor is connected.            Using a voltmeter, check for approximately +6 to -67 volts DC between the brake terminals. If there is no voltage, check for approximately +6 to -67 volts DC between terminals 1 and 3 on the control. If the voltage is present at the control and not at the brake, wires to the brake are open.            If there is no voltage at terminals 1 and 3 of the control, replace the printed circuit board assembly.            If there is voltage at the brake terminal, check the brake coil resistance with an ohmmeter for shorted brake puck.            Check for proper input signal.            Check to see that brake is wired properly.            Check to see that Brake Off input is not activated.</p>
Brake does not have the torque capacity required for the application.	<p>Verify that the correct brake was selected by repeating the selection procedure.</p>
Brake is not releasing as input level decreases.	<p>Check the mechanical parts of the brake to assure they are in good operating condition and properly installed. Check to see if Brake On input is activated.</p>
Roll shaft not free to rotate with control off.	<p>Brake and shaft must be free to rotate with control off.</p>
Inputs incorrectly connected to control terminals.	<p>Verify input connections.</p>
Is output LED off?	<p>Using a voltmeter, check the DC voltage at the brake terminals as follows: Slowly reduce the input level and observe that the voltage decreases—then slowly increase the input level and observe that the voltage increases. If the voltage indications are the opposite, reverse the input connections at terminals 5 and 7 of the control (see Sensor Wiring).</p>
(Problem occurs near roll core only!) Residual torque of the unwind stand exceeds the minimum torque allowable for the application.	<p>With input level at minimum settings, check that the DC voltage at the brake terminals reduces to 0 and reverse polarity.            If the voltage reduces and reverses polarity, check to be sure that the brake is in good operating condition and properly installed (see tension brake maintenance-torque loss). Also check to be sure that the unwind stand friction is not excessive for the application. Check the brake selection procedure to be sure the brake being used does not exceed the minimum allowable torques.            If the voltage did reduce to zero but did not reverse polarity, adjustment of the antiresidual may be necessary. If adjustment of the antiresidual does not cause the brake voltage to reverse polarity in the off state, replace the PC Board Assembly.</p>



## REPLACEMENT PARTS LIST

TCS-167 Power Supply.....	6910-448-025
Enclosure, TCS-167.....	6910-448-033
Fuse, 5A, 250V, Fast Acting, F1, F2, TCS-167 .....	458-8001-004
Fuse, 3A, 250V, Fast Acting, (F1-240 VAC only), TCS-167 .....	458-8001-006
TCS-210 Dancer Logic Control Module (complete) .....	6910-448-026
TCS-210 Replacement Driver Board Assembly .....	6910-448-035
TCS-210 Replacement Logic Board Assembly .....	6910-448-021
TCS-220 Remote/Analog Control Module (complete).....	6910-448-027
TCS-220 Replacement Driver Board Assembly .....	6910-448-036
TCS-220 Replacement Logic Board Assembly .....	6910-448-038
TCS-210/TCS-220 Housing, Panel Mount .....	6910-448-028
TCS-210/TCS-220 Housing, Wall/Shelf Mount .....	6910-448-029
Fuse, 1A, 250V, Fast Acting, F1, TCS-210, TCS-220 .....	458-8001-007
Fuse, 7A, 250V, Fast Acting, F2, TCS-210, TCS-220 .....	458-8001-078
MCS-605-1 Pivot Point Sensor (complete) .....	7330-448-002
TCS-605-5 Pivot Point Sensor 5-Turn .....	7330-448-003
Coupling, MCS-605-1 .....	248-8000-003
Coupling, Intermittent Motion, MCS-605-1 .....	6910-101-001
Roll Pin (Drive) for Pivot Sensor .....	679-8001-067
Cable Assembly, w/Connector for MCS-605-1 .....	7330-251-002

## LIST OF ILLUSTRATIONS AND FIGURES

Figure 1	TCS-210/TCS-220 Wall/Shelf Housing Dimensions .....	Page 8
Figure 2	TCS-210/TCS-220 W/S Label Orientation .....	Page 9
Figure 3	TCS-210/TCS-220 Panel Mount Label Orientation .....	Page 9
Figure 4	Panel Mounting Dimensions & Cut-Out, TCS-210/220 .....	Page 9
Figure 5	TCS-167 Open Frame Mounting Dimensions .....	Page 10
Figure 6	TCS-167 Enclosure Mounting Dimensions .....	Page 10
Figure 7	MCS-605-1 Mounting Details .....	Page 11
Figure 8	TCS-167/TCS-210 Interconnection Diagram .....	Page 13
Figure 9	TCS-167/TCS-220 Interconnection Diagram .....	Page 15
Figure 10	TCS-220 Input Wiring Configuration .....	Page 16
Figure 11	TCS-210 Internal/External Control Adjustments .....	Page 19
Figure 12	TCS-220 Internal/External Control Adjustments .....	Page 22



Warner Electric LLC  
449 Gardner Street • South Beloit, IL 61080  
815-389-3771 • Fax: 815-389-2582  
[www.warnerelectric.com](http://www.warnerelectric.com)