

Preassembled Clutch/Brake Module

Installation Instructions

P-273-1-WE
819-0343



 **Warner**[®]
Electric

An **Altra Industrial Motion** Company

Contents

| | |
|--------------------------------------|-----------|
| Mounting to a Motor | 3 |
| Mounting to a Reducer | 3 |
| Installing the Base Mount | 4 |
| Installing the Motor Mount | 4 |
| Electrical Connections | 4 |
| Start Up | 5 |
| Troubleshooting | 5 |
| Electrical Coil Data | 6 |
| Mechanical Data | 6 |
| Warranty | Back page |

⚠ WARNING Failure to follow these instructions may result in product damage, equipment damage, and serious or fatal injury to personnel.

Warner Electric's UniModule has been designed to NEMA standards and can be installed with all standard power transmission drive systems.

Before installing the UniModule to a motor or reducer, make certain that the UM UniModule size and NEMA frame dimensions match according to the following chart.

Corresponding NEMA Frame Sizes

| UM Size | Old NEMA | New NEMA | Shaft Dia. | C-Face Pilot Dia. |
|---------|----------|----------|------------|-------------------|
| 50 | 56 C | 48 Y | 5/8 | 4 1/2 |
| 100 | 56 C | 48 Y | 5/8 | 4 1/2 |
| 180 | 182 C | 143 TC | 7/8 | 4 1/2 |
| | 184 C | 145 TC | | |
| 210 | 213 C | 182 TC | 1-1/8 | 8 1/2 |
| | 215 C | 184 TC | | |
| 215 | | 213TC | 1 3/8 | 8 1/2 |
| | | 215 TC | 1 3/8 | 8 1/2 |

For These UM Combinations

Use These Installation Steps:

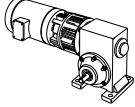
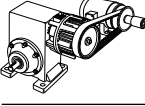
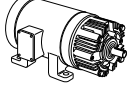
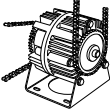
| | | |
|---|---|--|
|  | UniModule Clutch/Brake Between C-Face Motor and Reducer - 1020 UniModule Clutch between Motor and Reducer - 1040 | Mounting to a Motor Mounting to a Reducer Electrical Connections Start Up |
|  | UniModule Clutch/Brake - 2030 UniModule Clutch - 3040 | Chain or pulley Drive to a Reducer Electrical Connection Start Up |
|  | Motor Mount Module Clutch-Brake on a C-Face Motor - 1020-M Motor Mount UniModule Clutch on a C-Face Motor - 1040-M | Mounting to a Motor Installing the Motor Mount Electrical Connection Start Up |
|  | Base Mounted UniModule Clutch-Brake - 2030-B UniModule Clutch - 3040-B | Installing the Base Mount Electrical Connection Start Up |

Install your specific modular combination according to the installation steps specified in the table. Use only those steps indicated for each combination.

The 1020 and 1040 UniModules are furnished with a special hardened key. It is strongly recommended that this key be used with the motor shaft to avoid damage to the shaft and rotor hub.

The size 210 UniModules require an adapter ring to be mounted to the motor prior to mounting the 1020 or 1040 UniModule. Adapter and mounting hardware are provided with the UniModule assembly.

Note: The equipment covered by this service manual must be installed in accordance with these instructions. Failure to do so may damage the equipment and void the warranty.

Mounting to a Motor:

1. Replace the existing motor shaft key with the hardened key provided with the unit. If necessary, prick punch the keyway of the motor shaft to keep the key from moving in the keyway. Slide the module assembly onto the motor shaft. (See Figure 1) Align the key in the motor shaft with the keyway in the rotor hub.

Do not use force. If the UniModule does not slide on freely, polish the motor shaft sufficiently to achieve a slip fit.



Figure 1

2. The housing is provided with vent holes which are normally placed in the down position. Rotate the assembly to where the vent holes are toward the bottom and insert the four long capscrews (provided) through the mounting holes in the housing and into the motor face. Tighten alternately and securely. (30 to 35 ft. lbs.)

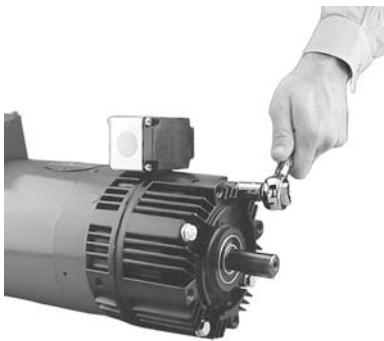

Figure 2

3. The access hole for the Allen wrench to tighten the rotor setscrews is shown in Figure 3. Rotate the clutch rotor as necessary to insert the wrench into the setscrews. Tighten both screws alternately and securely. Failure to properly tighten the setscrews may result in damage to the motor shaft and rotor hub and will void warranty. (40 to 45 in. lbs. for 180 size, 80 to 85 in. lbs. for 50 and 210 sizes.)



Figure 3

Mounting to a Reducer

The output side of a UniModule may be mounted directly to a reducer.

- A. Align the output shaft and key of the UniModule with the corresponding shaft hole and keyway of the reducer. Slide assembly together, matching pilot diameter on the UniModule with pilot diameter on the reducer.
- B. Bolt the UniModule to the reducer flange. The four (4) bolts required (3/8 - 16 UNC-2A) are normally furnished with the reducer. (18 to 22 ft. lbs. for 50 and 180 sizes, 40 to 45 lbs. for 210 size.)

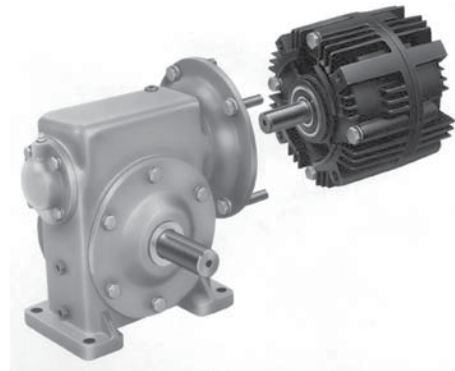

Figure 4

Installing the Base Mount

UniModules 2030 and 3040 can be base-mounted. (Figure 5)



Figure 5

- A. Mount each UniModule so that the base is located below the ventilation holes. A pilot diameter on the end of each UniModule mates with pilot diameters on the base.
- B. Secure the base to the UniModule with the four (4) bolts provided. (18 to 22 ft. lbs. for 50 and 180 sizes, 40 to 45 ft. lbs. for 210 size.)

Installing the Motor Mount (M)

- A. Motor Mount (M) can be installed to the output end of the UniModule to provide a foot mounting for the complete assembly of UniModule and motor.

Size 50, 100, and 180

- A. Remove the two (2) long hex head bolts from the side of the UniModule toward the ventilation holes.
- B. Mount the UniModule on the Motor Mount so that the base of the Motor Mount is underneath the UniModule and motor (Figure 6). A pilot diameter on the UniModule mates with a pilot diameter on the Motor Mount.
- C. Secure the Motor Mount in place with two (2) longer mounting bolts (30 to 35 ft. lbs.) and the two shorter bolts (18 to 22 ft. lbs.) all provided in the kit.

Size 210

- A. Mount the UniModule on the Motor Mount so that the base of the Motor Mount is underneath the UniModule and motor (Figure 6). A pilot diameter on the UniModule mates with a pilot diameter on the Motor Mount.
- B. Secure the Motor Mount to the UniModule with three (3) bolts provided. (40 to 45 ft. lbs.)



Figure 6

Electrical Connections

⚠ WARNING To avoid injury (or even death), always make certain all power is off before attempting to install or service this control or any electrical equipment.

The UniModule is provided with one conduit connection hole, threaded for standard 1/2" conduit connectors. Both the clutch and the brake lead wires are brought out through this opening. The conduit box accessory kit, P/N 5370-101-042, provides two conduit connection holes for standard 1/2" conduit connectors.

The clutch and brake coils operate on DC voltage. Warner Electric offers a full line of AC voltage powered controls to meet the needs of almost every clutch/brake application. The service and installation instructions included with each Warner Electric control show the proper electrical connections.

Please refer to the following figure for the proper UniModule electrical connections. **Clutch leads are identified with a white insulator sleeve.** **Brake leads have a black insulator sleeve.**

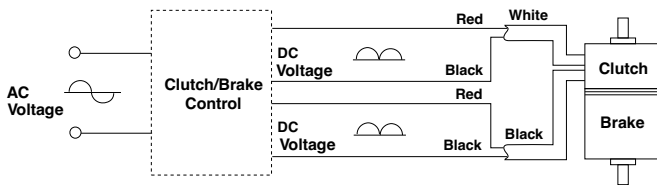

Start-Up

With the motor at rest, check the following:

- A. Spin the output shaft by hand to ensure that it turns freely. The bearings should be quiet and the armatures should not drag.
- B. With full voltage applied to the clutch or brake, switch back and forth between the clutch and brake and observe the armatures (plates) through the vent holes and opening in the fan. They should move back and forth approximately 1/32" when switched. Turn the output shaft as you check to be sure that the armatures fully engage 360 degrees.

Trouble Shooting - Electrical

If a clutch or brake or clutch/brake will not engage, review wiring, switching, and connections.

1. Using a multimeter, confirm that DC voltage is reaching the lead wires when it should be and that the coil resistance is correct. (See Electrical Coil Data)
2. Visually inspect to ensure that the lead wires are not split or cut.

Trouble Shooting - Mechanical

A likely mechanical cause for a clutch or brake not engaging when DC power is applied is that the airgap between the friction faces is too large. When power is applied to an Electro-magnetic clutch/brake, the unit magnetically clamps the friction faces together.

An airgap that is too large can keep the unit from clamping together. Sometimes this airgap, when set at the factory can shift during shipment or installation.

To reset the airgap, you will need to access the armatures. There are gaps between the fins on the housing on 1/3 of the unit circumference.

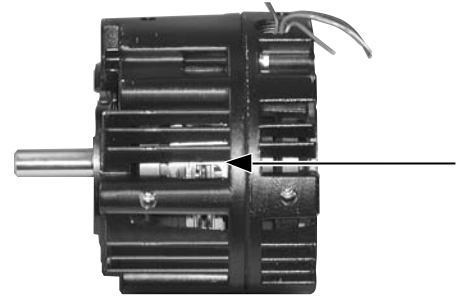

Figure 7

When looking through one of these gaps, you will see the fan on the clutch rotor. In that fan, there is a 1/2" x 1" window.

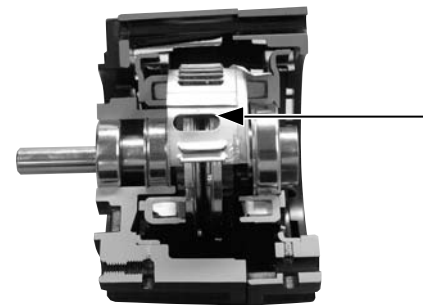

Figure 8

It is possible to look inside the unit and see the armatures by looking through this window. When looking into the window, you will be looking between the two armatures of a clutch/brake unit.

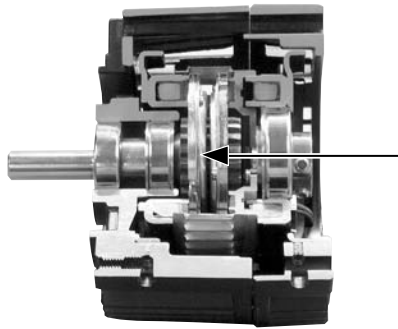

Figure 9

If the armature for either the clutch or the brake is too far away from its mating friction surface, it is possible to move this back into adjustment using a flat head screwdriver.

This is a three-step process.

1. Simply slide the screwdriver through the window and press the armature toward its mating friction surface.
2. Rotate the output of the unit. The rotor and window should stay in place when you do this. Only the armatures will move. Rotating the rotor will move the window.
3. Repeat steps 1 & 2 to ensure that the airgap between the armature and its mating friction surface is about 1/32" and that the armature is kept square. (If the armature is cocked, it may engage on one rim, giving the appearance of engagement but failing to provide full torque.)

If a scraping sound is noted when the output shaft is spun, it means an armature is dragging. Insert a screwdriver through the vent holes and slot in the fan and pry the dragging armature (clutch or brake as observed) away from the mating surface evenly all the way around. Re-check the engagement as described in step B of the Start-Up instructions.

Electrical Coil Data

| | | Clutch Brake | | Clutch Brake | | Clutch Brake | |
|----------------|------------|--------------|------|--------------|------|--------------|------|
| | | 90 | 90 | 24 | 24 | 6 | 6 |
| Voltage—D.C. | | | | | | | |
| Resistance | UM-50 | 452 | 452 | 31.8 | 31.8 | 1.86 | 1.86 |
| (OHMS) | UM-100/180 | 392 | 392 | 26.7 | 26.7 | 1.81 | 1.81 |
| | UM-210/215 | 248 | 248 | 17.9 | 17.9 | 1.22 | 1.22 |
| Amperes | UM-50 | .199 | .201 | .755 | .755 | 3.23 | 3.23 |
| | UM-100/180 | .230 | .230 | .896 | .896 | 3.31 | 3.31 |
| | UM-210/215 | .363 | .363 | 1.34 | 1.34 | 4.9 | 4.9 |
| WATTS (17.9) | UM-50 | 18 | 18 | 18.1 | 18.1 | 19.4 | 19.4 |
| | UM-100/180 | 20.7 | 20.7 | 21.5 | 21.5 | 20.0 | 20.0 |
| | UM-210/215 | 32.7 | 32.7 | 32 | 32 | 29.6 | 29.6 |
| Build Up | UM-50 | 52 | 53 | 52 | 53 | 52 | 53 |
| (Milliseconds) | UM-100/180 | 72 | 75 | 72 | 75 | 72 | 70 |
| | UM-210/215 | 120 | 100 | 120 | 100 | 110 | 100 |
| Decay | UM-50 | 6.2 | 5.0 | 6.2 | 5.0 | 6.5 | 5.0 |
| (Milliseconds) | UM-100/180 | 12 | 10 | 12 | 10 | 12 | 10 |
| | UM-210/215 | 20 | 10 | 20 | 10 | 20 | 10 |

Mechanical Data

| | UM-50 | UM-100/180 | UM-210/215 |
|-------------------------|-------|------------|------------|
| Static Torque - lb. ft. | 16 | 30 | 95 |
| Maximum Speed - rpm | 3600 | 3600 | 3600 |
| Average Weight-lbs. | | | |
| 1020 | 10 | 13.2 | 30.6/31 |
| 1040 | 8.3 | 10.3 | 24.3/25 |
| 2030 | 13 | 16.5 | 41.3/42 |
| 3040 | 11.3 | 13.6 | 35/35.5 |

Inertia - WR - lb.ft.

| Configuration | 50 | 100/180 | 210 | 215 |
|---------------|-------|---------|------|------|
| 1020 input | .021 | .047 | .190 | .190 |
| 1020 output | .0195 | .050 | .193 | .195 |
| 1040 input | .021 | .047 | .190 | .190 |
| 1040 output | .0105 | .027 | .112 | .114 |
| 2030 input | .021 | .048 | .198 | .200 |
| 2030 output | .0195 | .050 | .193 | .195 |
| 3040 input | .021 | .048 | .198 | .200 |
| 3040 output | .0105 | .027 | .112 | .114 |

Warranty

Warner Electric LLC warrants that it will repair or replace (whichever it deems advisable) any product manufactured and sold by it which proves to be defective in material or workmanship within a period of one (1) year from the date of original purchase for consumer, commercial or industrial use.

This warranty extends only to the original purchaser and is not transferable or assignable without Warner Electric LLC's prior consent.

Warranty service can be obtained in the U.S.A. by returning any defective product, transportation charges prepaid, to the appropriate Warner Electric LLC factory. Additional warranty information may be obtained by writing the Customer Satisfaction Department, Warner Electric LLC, 449 Gardner Street, South Beloit, Illinois 61080, or by calling 815-389-3771.

A purchase receipt or other proof of original purchase will be required before warranty service is rendered. If found defective under the terms of this warranty, repair or replacement will be made, without charge, together with a refund for transportation costs. If found not to be defective, you will be notified and, with your consent, the item will be repaired or replaced and returned to you at your expense.

This warranty covers normal use and does not cover damage or defect which results from alteration, accident, neglect, or improper installation, operation, or maintenance.

Some states do not allow limitation on how long an implied warranty lasts, so the above limitation may not apply to you.

Warner Electric LLC's obligation under this warranty is limited to the repair or replacement of the defective product and in no event shall Warner Electric LLC be liable for consequential, indirect, or incidental damages of any kind incurred by reason of the manufacture, sale or use of any defective product. Warner Electric LLC neither assumes nor authorizes any other person to give any other warranty or to assume any other obligation or liability on its behalf.

WITH RESPECT TO CONSUMER USE OF THE PRODUCT, ANY IMPLIED WARRANTIES WHICH THE CONSUMER MAY HAVE ARE LIMITED IN DURATION TO ONE YEAR FROM THE DATE OF ORIGINAL CONSUMER PURCHASE. WITH RESPECT TO COMMERCIAL AND INDUSTRIAL USES OF THE PRODUCT, THE FOREGOING WARRANTY IS IN LIEU OF AND EXCLUDES ALL OTHER WARRANTIES, WHETHER EXPRESSED OR IMPLIED BY OPERATION OF LAW OR OTHERWISE, INCLUDING, BUT NOT LIMITED TO, ANY IMPLIED WARRANTIES OF MERCHANTABILITY OR FITNESS.

Some states do not allow the exclusion or limitation of incidental or consequential damages, so the above limitation or exclusion may not apply to you. This warranty gives you specific legal rights and you may also have other rights which vary from state to state.

Changes in Dimensions and Specifications

All dimensions and specifications shown in Warner Electric catalogs are subject to change without notice. Weights do not include weight of boxing for shipment. Certified prints will be furnished without charge on request to Warner Electric.



www.warnerelectric.com

31 Industrial Park Road
New Hartford, CT 06057
815-389-3771
Fax: 815-389-2582

An **Altra Industrial Motion** Company

