

# TCS-605-1 Pivot Point Tension Sensor for Warner Electric Tension Control System

Installation Instructions

P-0362-WE  
819-0551



 **Warner**<sup>®</sup>  
Electric

An **Altra Industrial Motion** Company

## TCS-605-1 Pivot Point Tension Sensor

The TCS-605-1 Tension Sensor is used with the Warner Tension Control System to provide smooth control of unwind stands operating at any speed. The sensor is especially convenient in applications having small dancer arms and is complete with versatile mounting brackets. The pivot point sensor does not add additional weight to the dancer arm.

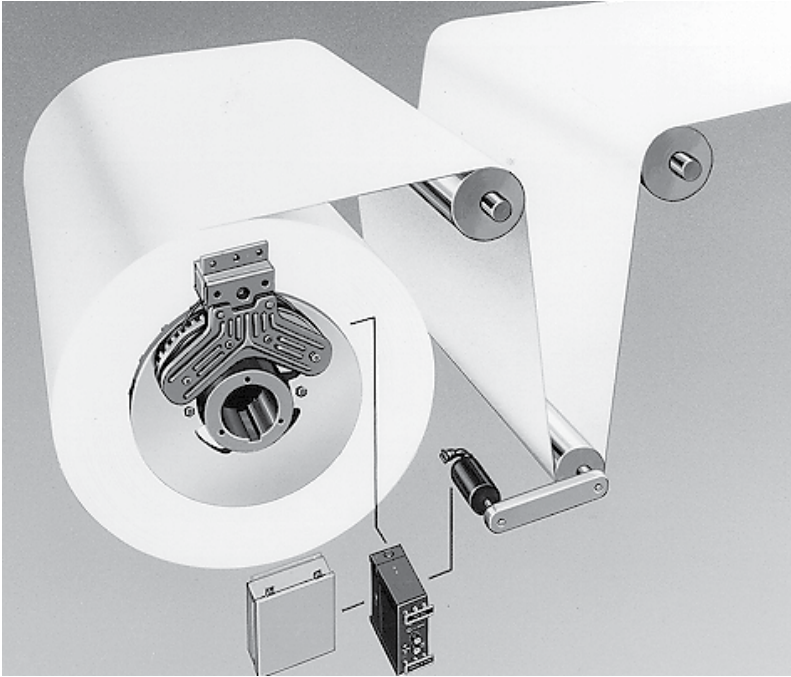

TCS-605 Pivot Point Sensor



TCS-605 Pivot Point Sensor

## A Complete Dancer System

- For Unwind Stands
- Dancer Roll System
- Stable
- Electromagnetic Brakes
- Quiet
- Closed Loop Control
- Off-the-shelf Availability from your local Warner Distributor

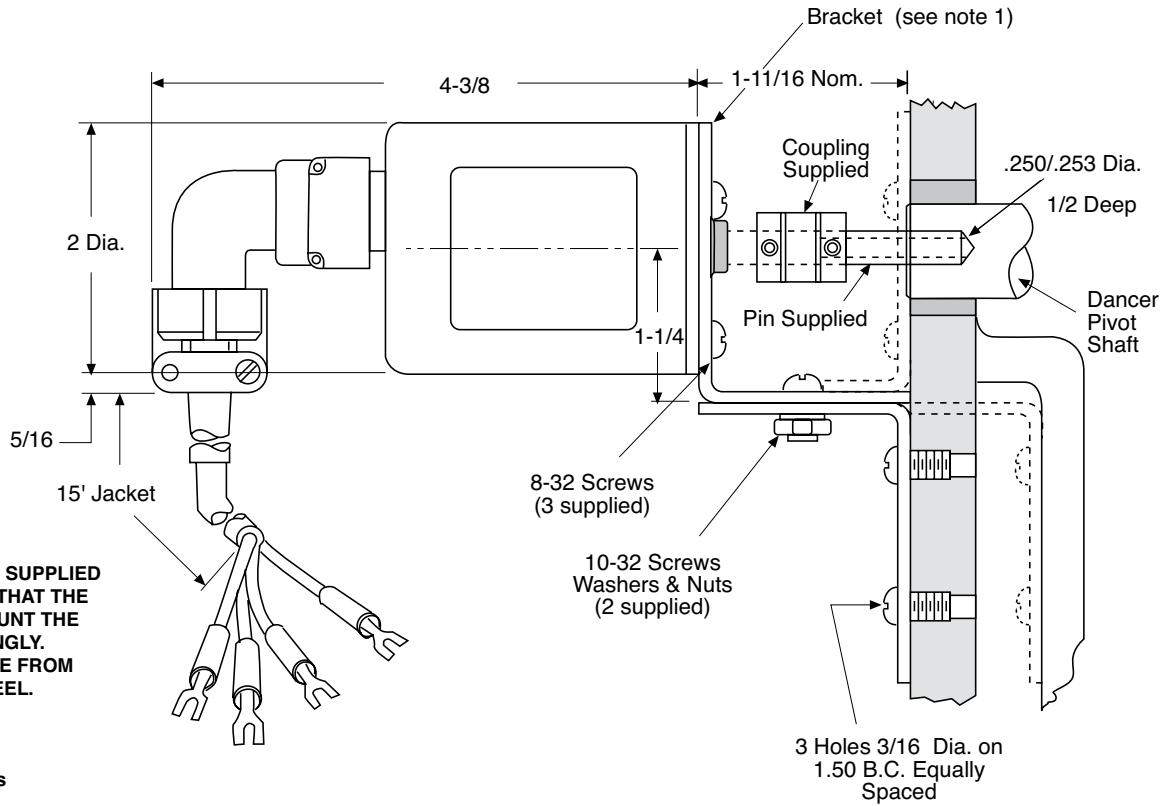

**NOTES:**

1. TWO BRACKETS ARE SUPPLIED WITH EACH UNIT SO THAT THE CUSTOMER CAN MOUNT THE TCS-605-1 ACCORDINGLY.
2. BRACKETS ARE MADE FROM 14 GAUGE (.0747) STEEL.

**Replaceable Components**

Sensor only TCS-605-1	7330-101-002
Cable assembly only	7330-101-001

1. Using a 1/4" drill, drill a hole in the center of the dancer pivot shaft 1/2" deep.
2. Drive the supplied pin into the hole in the shaft until half its length remains exposed.
3. Assemble the brackets and mount the sensor on the bracket.
4. Position the sensor and bracket on the machine so the sensor shaft and the pin are aligned and separated by 1/8 to 1/4 inch. While holding the sensor and bracket in the above position, mark the centers of the bracket holes on the machine. Drill and tap holes in the machine for 8-32 screws.
5. Connect the sensor shaft to the pin with the flexible coupling provided. The index mark on the sensor shaft must be aligned with the index mark on the sensor face when the dancer arm is near the midtravel position.
6. Mount the sensor and bracket to the machine. Connect the sensor to the tension control unit with the cable assembly in accordance with the instructions supplied with the control unit.

## Warranty

Warner Electric LLC warrants that it will repair or replace (whichever it deems advisable) any product manufactured and sold by it which proves to be defective in material or workmanship within a period of one (1) year from the date of original purchase for consumer, commercial or industrial use.

This warranty extends only to the original purchaser and is not transferable or assignable without Warner Electric LLC's prior consent.

Warranty service can be obtained in the U.S.A. by returning any defective product, transportation charges prepaid, to the appropriate Warner Electric LLC factory. Additional warranty information may be obtained by writing the Customer Satisfaction Department, Warner Electric LLC, 449 Gardner Street, South Beloit, Illinois 61080, or by calling 815-389-3771.

A purchase receipt or other proof of original purchase will be required before warranty service is rendered. If found defective under the terms of this warranty, repair or replacement will be made, without charge, together with a refund for transportation costs. If found not to be defective, you will be notified and, with your consent, the item will be repaired or replaced and returned to you at your expense.

This warranty covers normal use and does not cover damage or defect which results from alteration, accident, neglect, or improper installation, operation, or maintenance.

Some states do not allow limitation on how long an implied warranty lasts, so the above limitation may not apply to you.

Warner Electric LLC's obligation under this warranty is limited to the repair or replacement of the defective product and in no event shall Warner Electric LLC be liable for consequential, indirect, or incidental damages of any kind incurred by reason of the manufacture, sale or use of any defective product. Warner Electric LLC neither assumes nor authorizes any other person to give any other warranty or to assume any other obligation or liability on its behalf.

WITH RESPECT TO CONSUMER USE OF THE PRODUCT, ANY IMPLIED WARRANTIES WHICH THE CONSUMER MAY HAVE ARE LIMITED IN DURATION TO ONE YEAR FROM THE DATE OF ORIGINAL CONSUMER PURCHASE. WITH RESPECT TO COMMERCIAL AND INDUSTRIAL USES OF THE PRODUCT, THE FOREGOING WARRANTY IS IN LIEU OF AND EXCLUDES ALL OTHER WARRANTIES, WHETHER EXPRESSED OR IMPLIED BY OPERATION OF LAW OR OTHERWISE, INCLUDING, BUT NOT LIMITED TO, ANY IMPLIED WARRANTIES OF MERCHANTABILITY OR FITNESS.

Some states do not allow the exclusion or limitation of incidental or consequential damages, so the above limitation or exclusion may not apply to you. This warranty gives you specific legal rights and you may also have other rights which vary from state to state.

### Changes in Dimensions and Specifications

All dimensions and specifications shown in Warner Electric catalogs are subject to change without notice. Weights do not include weight of boxing for shipment. Certified prints will be furnished without charge on request to Warner Electric.



[www.warnerelectric.com](http://www.warnerelectric.com)

31 Industrial Park Road  
New Hartford, CT 06057  
815-389-3771  
Fax: 815-389-2582

An **Altra Industrial Motion** Company

