

## P1 Electronic Stroke Limit Control

Model Selection			
Model No.	Input Voltage (vdc)	Maximum Output Current (Amps)	Features
P1.0 (DC12)	12	25	Base = Electronic Stroke Limit with Electronic Dynamic Braking
P1.0 (DC24)	24	12.5	Base = Electronic Stroke Limit with Electronic Dynamic Braking
P1.1 (DC12)	12	25	Base & LED indicators on Housing
P1.1 (DC24)	24	12.5	Base & LED indicators on Housing
P1.2 (DC12)	12	25	Base & +12 vdc Outputs
P1.2 (DC24)	24	12.5	Base & +24 vdc Outputs
P1.2LE (DC12)	12	25	Base & LED Outputs +5 vdc
P1.2LE (DC24)	24	12.5	Base & LED Outputs +5 vdc

**Note:** For adjustable external end limits add E before P

### Wiring Diagrams

#### P1 Module P1.0-DC12/24

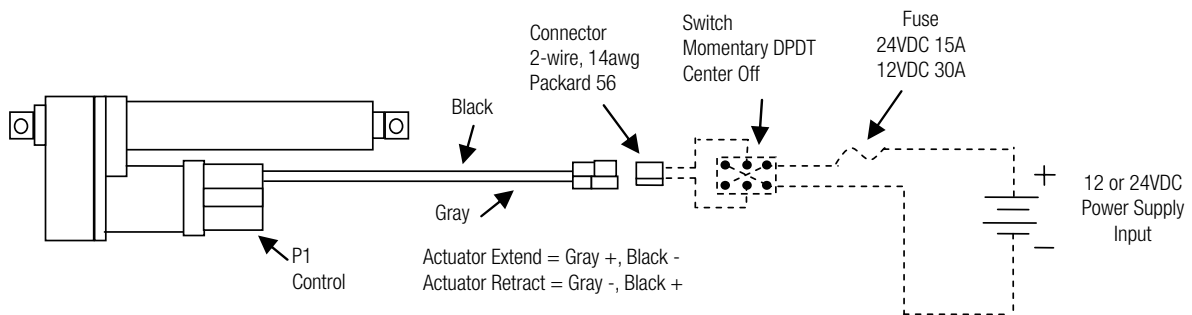

All dashed lines are customer supplied connections

### Operation

When the "Customer Supplied Switch" is held in the direction allowing positive 12 or 24VDC to the gray wire and 12 or 24VDC ground to the black wire, the actuator will extend until it reaches the end of stroke. At the end of stroke, which is determined by the factory set location of the Hall effect switches inside the actuator cylinder, power will be removed to the actuator by the P1.0 control. The actuator will no longer move in that direction even if the customer supplied switch is held.

When the switch is held in the opposite direction so the positive lead of the 12 or 24VDC signal is on the black wire and the 12 or 24VDC ground is on the gray wire, the actuator will retract until it returns to the full home position which is determined by the factory set location of the second Hall effect switch.

If the actuator does not stop when at either end then something in the actuator or P1.0 control may be damaged. Please call the factory for further analysis.

The actuators are 100% tested before leaving the factory.

## P1 Electronic Stroke Limit Control

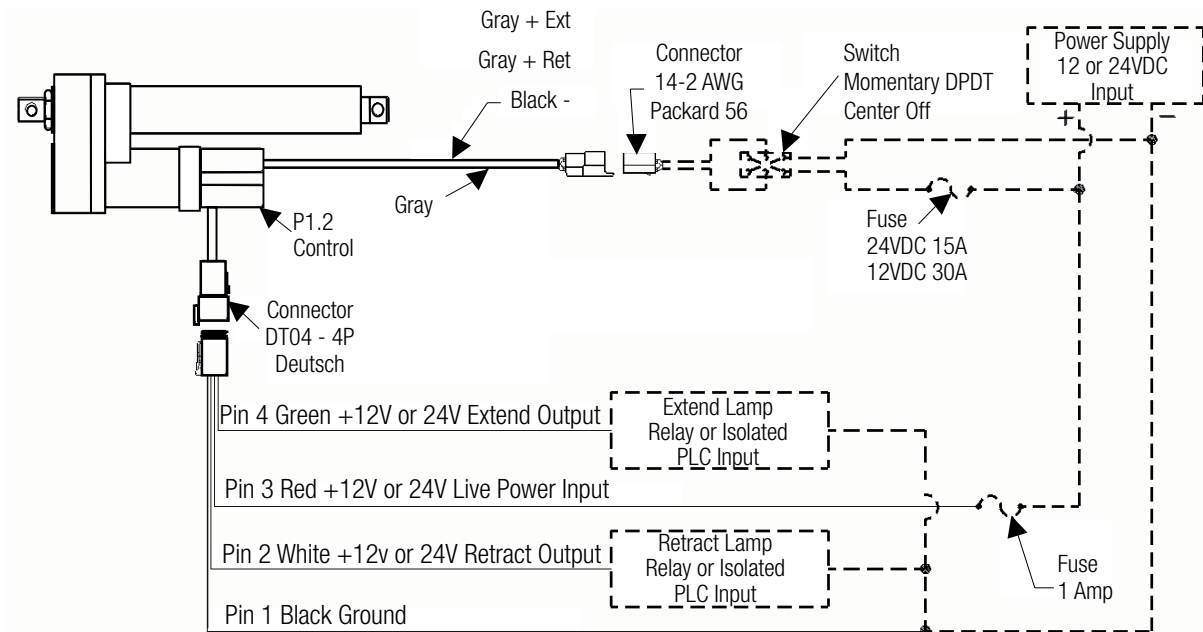

All dashed lines are customer supplied connections

### Operation

When the “Customer Supplied Switch” is held in the direction allowing positive 12 or 24VDC to the gray wire and 12 or 24VDC ground to the black wire, the actuator will extend until it reaches the end of stroke. At the end of stroke the “Extend Output” (green wire) will have +12 or 24 Volts to ground, indicating it is at the end. This signal can be used to light a Lamp, signal a relay coil, or an isolated PLC input that only requires 500mA or less. This output will only be on as long as power is maintained from the “Customer Supplied Switch”.

However, if the output needs to be on even if the “Customer Supplied Switch” is not activated then the “Live Power input” can be used. This will provide power all the time for the output to remain on whenever the Actuator is at either travel end.

Apply +12 VDC (for 12VDC unit) or +24 VDC (for @24VDC unit) to the red wire of the Deutsch (DT04-4P) 4 pin connector and ground to the black wire. This supply needs to be the same supply as the actuator and will require less than 500mA.

When the switch is held in the opposite direction so the positive lead of the 12 or 24VDC signal is on the black wire and the 12 or 24VDC ground is on the gray wire, the actuator will retract until it returns to full home position. At the full home position, the “Retract Output” (white wire) will have +12 or 24 volts to ground.

**CAUTION Do not reverse polarity at live power input (i.e. 22GA red & black wires) or damage will occur.**