

## PQS Quick Stop Control



The PQS is a bi-directional current limit control. The control monitors current during actuator motion and quickly stops the actuator if an object gets in the way or at the end of stroke. The actuator will remain off until power is reapplied. The current limit setting is adjustable with two potentiometers that are accessible through two plugged holes on the side of the housing.

### Features

**Quick Stop:** Field adjustable potentiometers limit the amount of current through the motor in one or both directions. Both potentiometers are factory set to the maximum actuator current unless otherwise specified. Potentiometers field adjustable also.

**Motor Power:** Switched by on board relay. The relay allows power to the motor as long as the actuator is not being commanded to go past the end limits.

**Faster Stopping:** Electronic dynamic braking, (EDB) is applied after every move for more accurate and faster stops.

**Load Limit Trip Outputs:** These outputs indicate when the current limit has been exceeded in either direction. They are active low transistor outputs.

**Enclosure:** Attaches to back of motor or other surface and is potted to work in harsh environments.

**Protection:** Zener diode suppression on the input and output for extra protection in noisy environments.

### Specifications

<b>Supply Power:</b>	12 or 24 VDC
<b>Maximum Current</b>	25 Amps @ 12VDC / 12.5 Amps @ 24VDC (at 25% duty cycle)
<b>Operating Temperature:</b>	-20° F to +150° F (-29° C to +66° C)

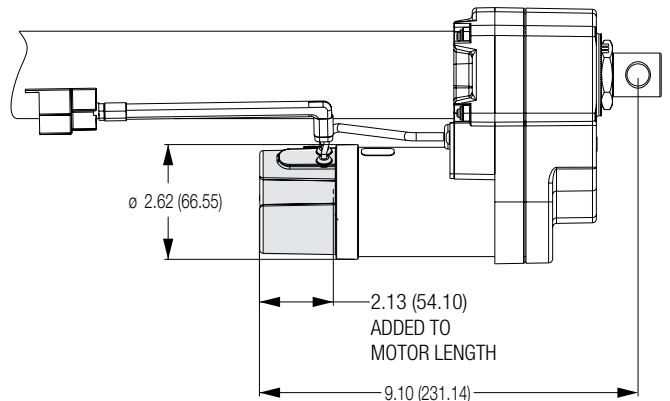

### Adjusting Extend &/or Retract Trip Current

- Remove access plugs on the side of control.
- Rotate trim pot counter clockwise for min. load.
- Rotate trim pot clockwise for max. load.
- Adjust the Retract pot to control closing force.
- Adjust the extend pot to control lifting force.
- Adjust as viewed with extension rod pointing up.
- Reinstall access plugs.

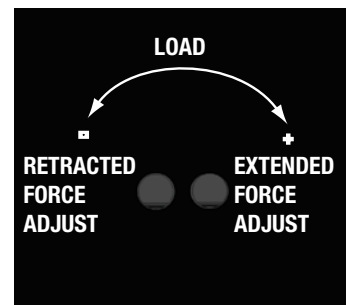

### Electric Rating & Model Selection

Model No.	Input Voltage (vdc)	Maximum Output Current (Amps)	Features
PQS-12V	12	25	Base = Electronic Stroke Limit with mid-stroke current limit and Electronic Dynamic Braking
PQS-24V	24	12.5	
PQS.2-12V	12	25	Base & +12VDC Trip Outputs
PQS-24V	24	12.5	Base & +24VDC Trip Outputs

## PQS Quick Stop Control Wiring Diagrams

### PQS-12V/24V Module

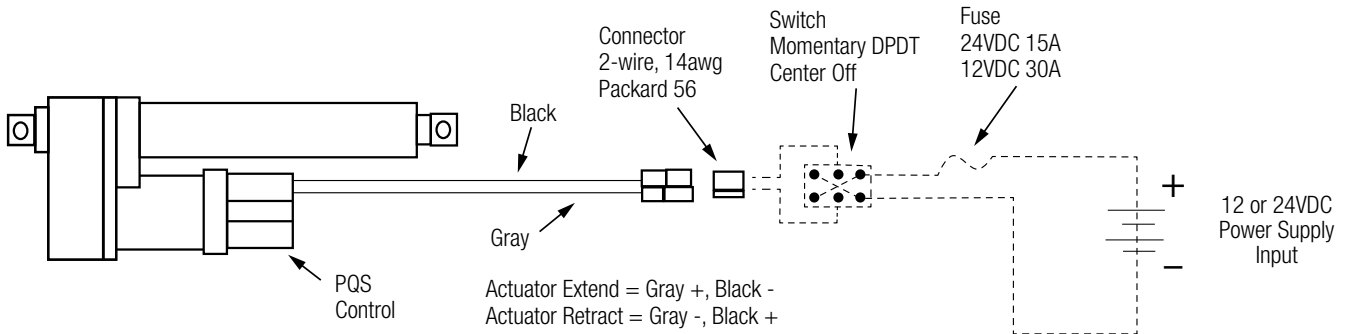

All dashed lines are customer supplied connections

### PQS.2-12V/24V Module

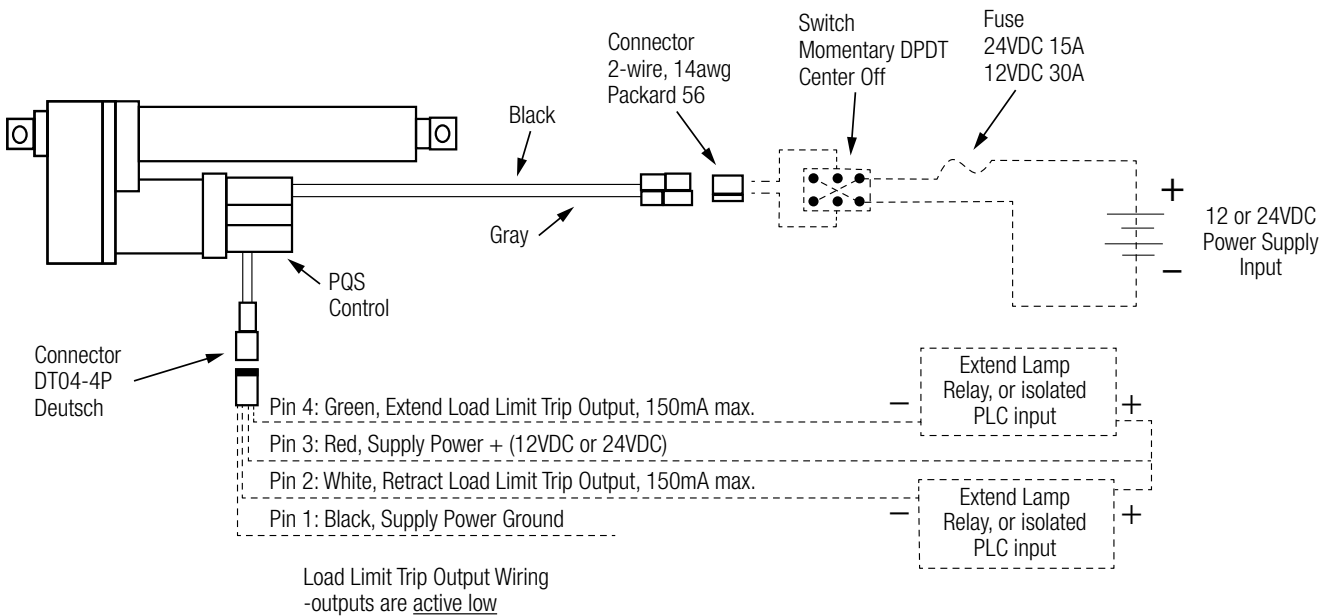

All dashed lines are customer supplied connections