

B-Track K2x

Rugged Duty Actuator DC Motor Ball Screw

Up to 2,800 lbs. (12455 N) Rated Load
Up to 2.1 in. (53.34mm)/sec. Travel Speed



The K2x model provides the highest load rating in its class. This model incorporates all of the base K2 features with a ball nut screw for a 2,800 lb. (12455 N) load capability within a compact package size. The K2x includes a bi-directional wrap spring brake for load holding capability. These units are well suited for the most demanding applications where an alternative to hydraulic or air cylinders is needed or where hydraulic power sources are not available.

Combining the K2x actuator with BTc control functionality results in precision actuator control at a fraction of the cost of more complicated servo actuator systems. See Controls Section for more information on BTc controls.

Now Available Optional Adjustable Limit Switch These easy to use adjustable switches are mounted in a channel on the cover tube with custom cap for protection. They are easily moved to enable the end-user the flexibility of setting the stroke length at any position within the full stroke capability.

Features

- **Protective coatings** and O-ring seals throughout
- **Efficient in-line** ball screw system
- **Integral load** holding brake
- **Ball detent overload clutch**
- **Stroke lengths** 2 to 24 inches (50 to 600 millimeters)
- **Load capacities** up to 2,800 pounds (12455 N)
- **Speeds up to** 2.1 inches (53.34 mm)/sec. travel
- **Thermal overload** incorporated into the motor
- **Heavy wall construction**
- **Double ball bearing motors**
- **Heat treated gears**
- **Rugged extension rod** bearing support
- **Optional 90 vdc motor** for use with SBC-AC control (IP 54)
- **Custom mounting** options available

Typical Applications

- Paving equipment
- Deck and implement lifts for tractors and mobile applications
- Spray booms
- Scissor and dump box lifts



Scan to watch!

How to Adjust the Limit Switches for a K2 or K2X Actuator with External or EP Limit Switches
<https://p.widencdn.net/imzc9v>

Load/Current/Speed/Duty Cycle

- Maximum Static Rating: 3,000 lbs. (13345 N) Static (in-line load)
- Refer to performance chart for load/current/speed capabilities
- Stroke Length Tolerance: +/- .06" (1.52 mm)
- Motor is protected with auto reset breaker inside motor housing (temperature/current/time dependent)
- Overload clutch setting: +25% over rated dynamic load
- Duty cycle is time/temperature/load dependent, suggested guidelines are:
 - 50% max on-time/50% off-time for loads up to 50% of capability
 - 25% max on-time/75% off-time for loads between 50%-80% of capability
 - 10% max on-time/90% off-time for loads between 80%-100% of capability

(Load/stroke profiles will allow some adjustment variation from these guidelines.)

Operating Environment

- Ambient temp range: -20° F to +150° F (-29° C to +65° C), -40°F to +176°F (-40°C to +80°C) Upon Request.
- Weather resistant enclosure & seals (IP69K static, IP65 capable, 250 hour salt spray, 500 hour for paint)
- Normal operating voltage: 10-16 vdc (Ratings are at 12 vdc Normal.)

Control/Connections

- 14 gauge stranded lead wires-UL style 1230 w/PVC insulation Class F 105° C
- Lead wires abrasion protected with spiral covering
- Use momentary contact double pole/double throw switch in powering unit for extend/retract operation. (ON)-OFF-(ON) DPDT
- Connectors:
 - Packard 56 series or Delphi Weather-Pack
 - Packard 56 series with 56 series blades (#2984883 & #2962987)
 - Delphi Weather-Pack series (#121015792 & #12010973) Upon Request

Performance Graphs Imperial Measurements*

*Performance Chart Measurements are Nominal



Load Capacity 600 lbs.

For Metric Measurements, see page 38.

K2XG05-12VDC

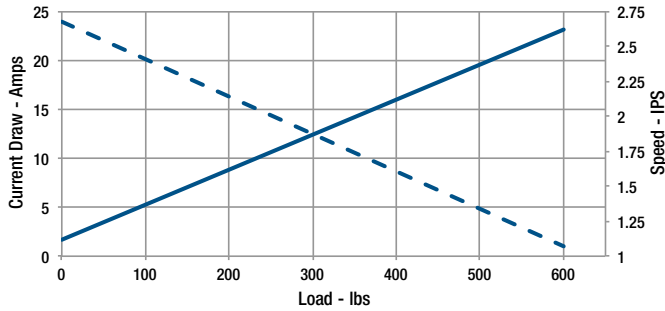

K2XG05-24VDC

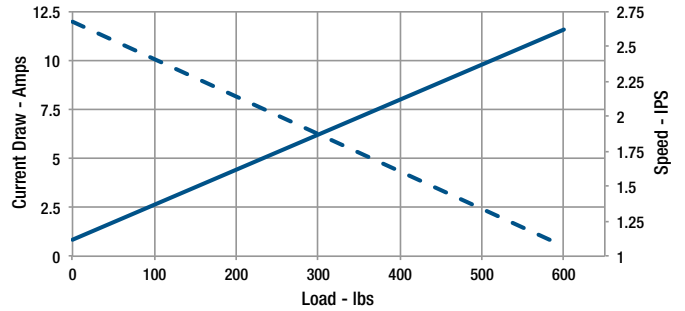

Load Capacity 1200 lbs.

For Metric Measurements, see page 38.

K2XG10-12VDC

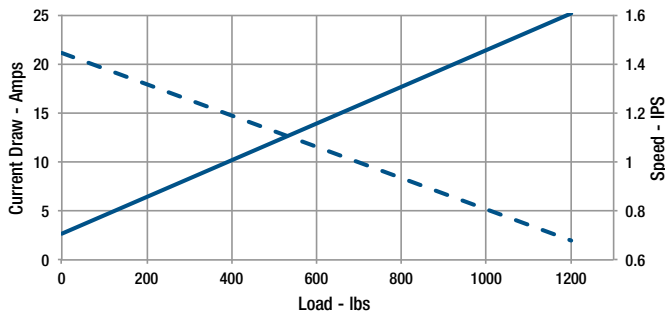

K2XG10-24VDC

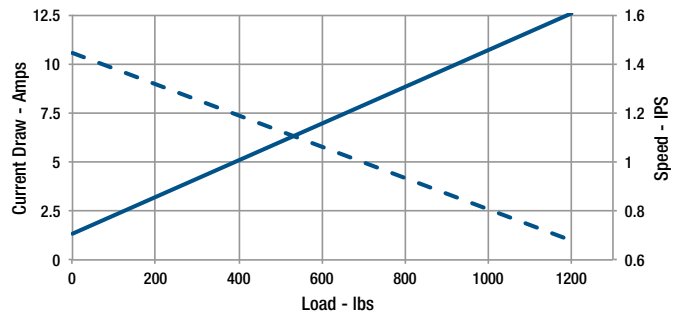

Load Capacity 2200 lbs.

For Metric Measurements, see page 38.

K2XG20-12VDC

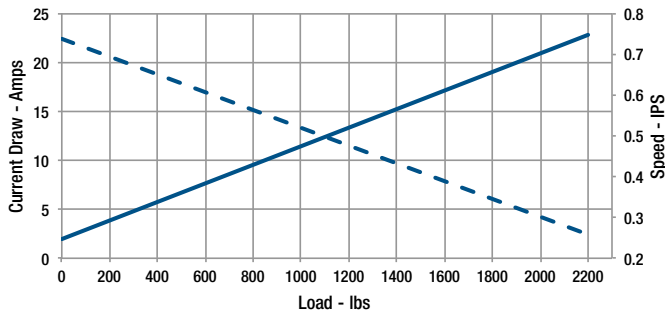

K2XG20-24VDC

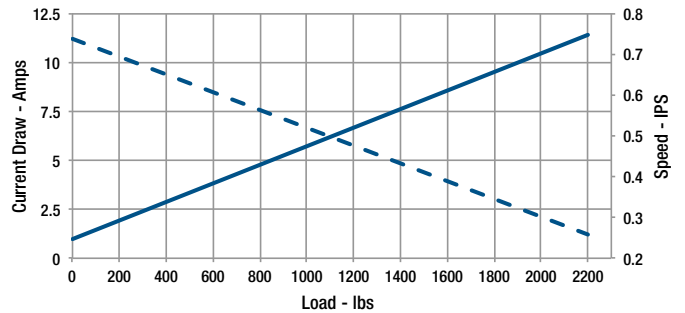

Load Capacity 2800 lbs.

For Metric Measurements, see page 38.

K2XG30-12VDC

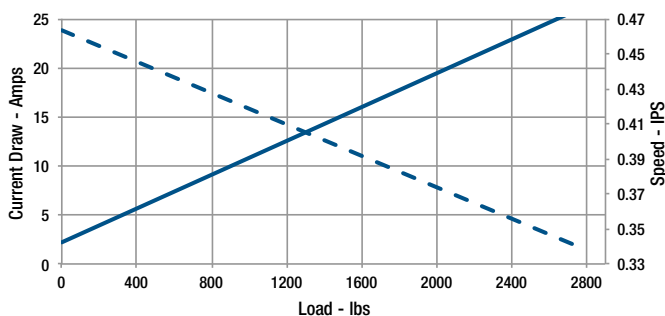

K2XG30-24VDC

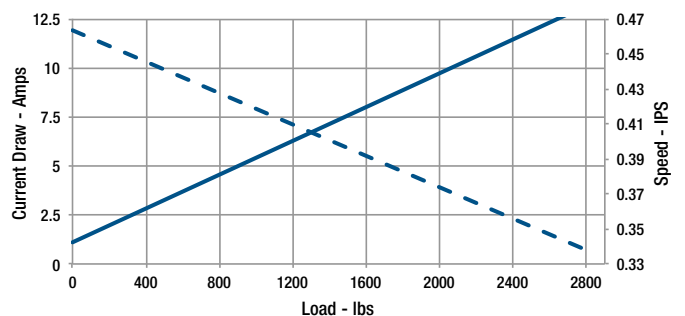

B-Track K2x

Performance Graphs Metric Measurements*

*Performance Chart Measurements are Nominal

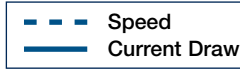

Load Capacity 2670 N

For Imperial Measurements, see page 37.

K2XG05-12VDC

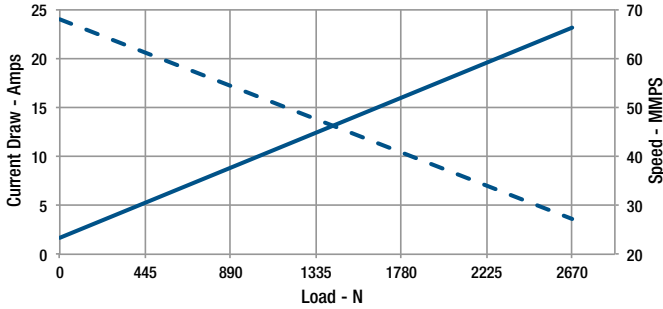

K2XG05-24VDC

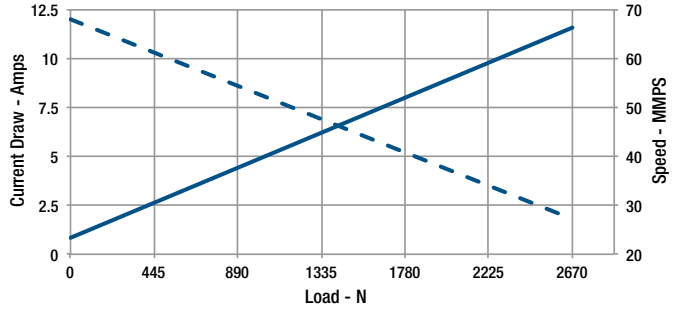

Load Capacity 5340 N

For Imperial Measurements, see page 37.

K2XG10-12VDC

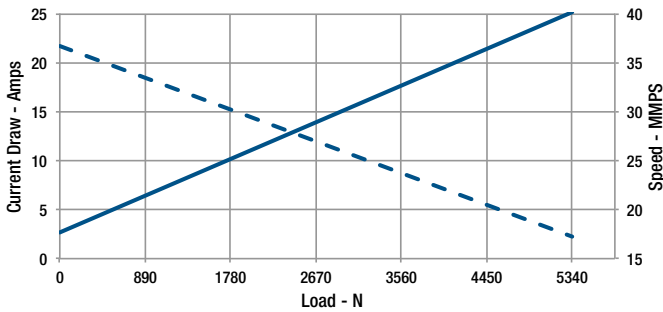

K2XG10-24VDC

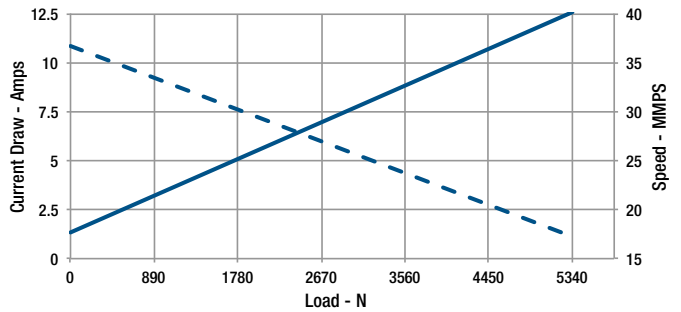

Load Capacity 9790 N

For Imperial Measurements, see page 37.

K2XG20-12VDC

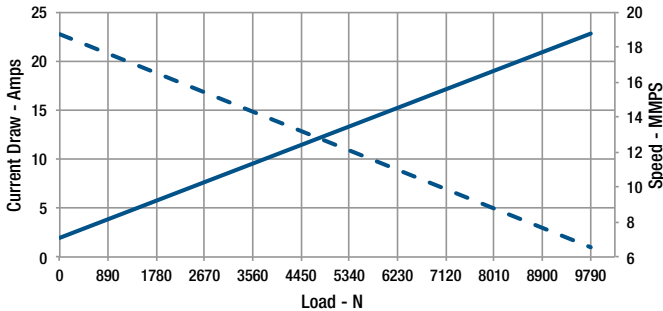

K2XG20-24VDC

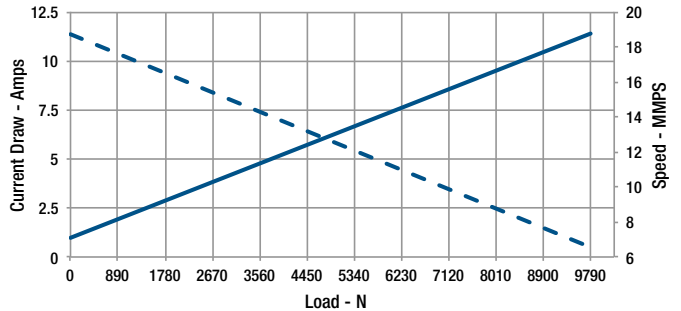

Load Capacity 12,460 N

For Imperial Measurements, see page 37.

K2XG30-12VDC

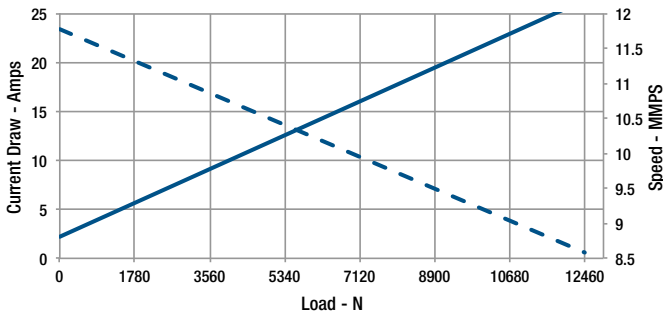

K2XG30-24VDC

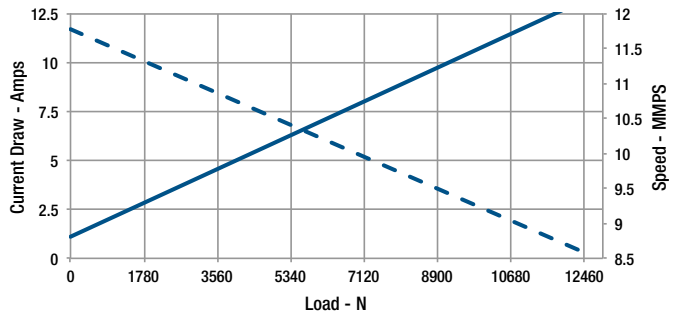

Dimensions

B-Track K2x	Stroke	in.	mm	in.	mm	in.	mm	in.	mm	in.	mm	in.	mm
		2	51	4	102	6	152	8	203	10	254	12	305
	A	9.89	251.2	11.89	302.0	13.89	352.8	15.89	403.6	17.89	454.4	19.89	505.2

Note: Special lengths available

B-Track K2x	Stroke	in.	mm	in.	mm	in.	mm	in.	mm	in.	mm	in.	mm
		14	356	16	406	18	457	20	508	22	559	24	610
	A	21.89	556.0	23.89	606.8	25.89	657.6	30.89	784.6	32.89	835.4	34.89	886.2

Note: Special lengths available

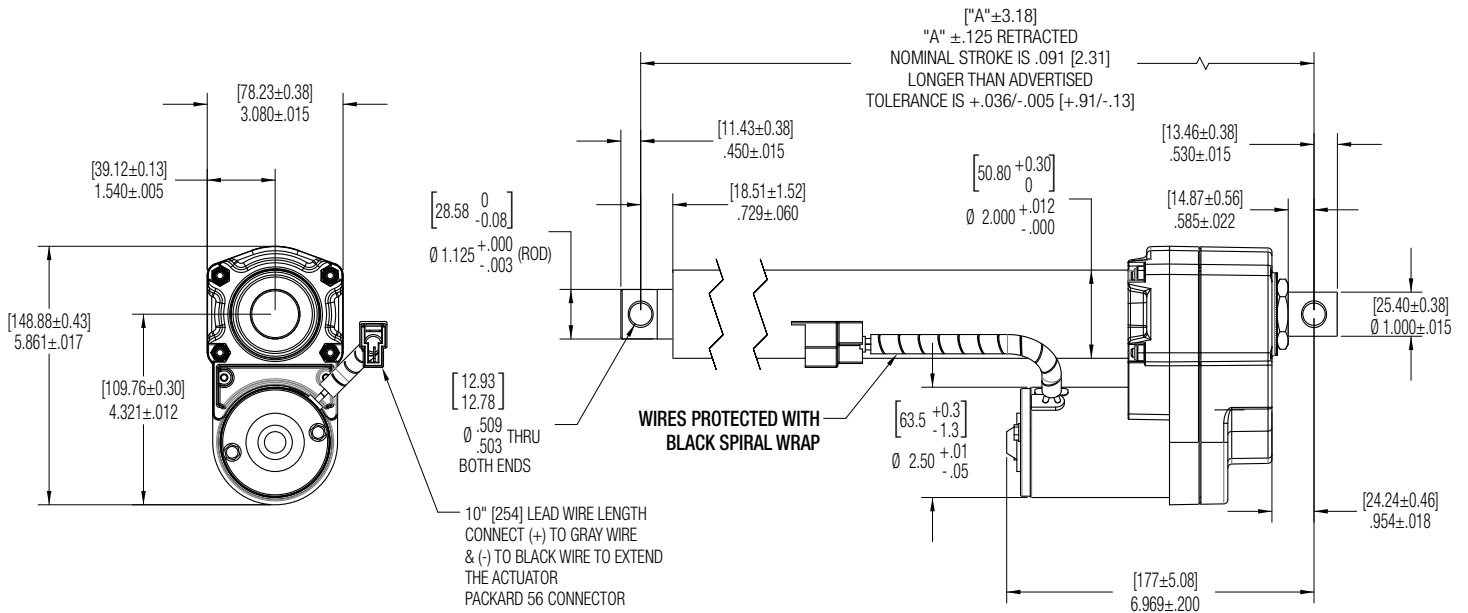

**ALL DIMENSIONS ARE NOMINAL
UNLESS OTHERWISE SPECIFIED**

Measurements in inches, metric in brackets.