

How To Select

Step 1 – Determine Load and Stroke length requirements

Use the Quick Selection guide to identify the model that will provide the load capacity and stroke length needed for your application.

Step 2 – Identify motor type and voltage

Select DC motor and motor voltage.

Step 3 – Confirm Speed and Current draw requirements

Using the charts provided, confirm that unit speed and current draw is appropriate for the intended use.

Step 4 – Confirm the application Duty Cycle

At full load capacity, actuators have a 25% duty cycle.

Duty cycle is the amount of $\frac{\text{on-time}}{\text{on-time} + \text{off-time}}$

A unit that runs for 15 seconds should be off for 45 seconds.

Important Unit Restrictions

Side loading and shock loads must be considered in actuator applications. Side loading and cantilevered mounting should be eliminated through proper machine design. Side loading will dramatically reduce unit life. While actuators can withstand limited shock loads, it is recommended that shock loading be avoided wherever possible. (See General Mounting Information on page 71)

Step 5 – Unit Options

M-Track units include end-of-travel limit switches as a standard feature. For positional feedback, a 12K linear membrane potentiometer can be factory installed. The changing potentiometer value provides unit movement feedback for units that are not visible to the machine operator.

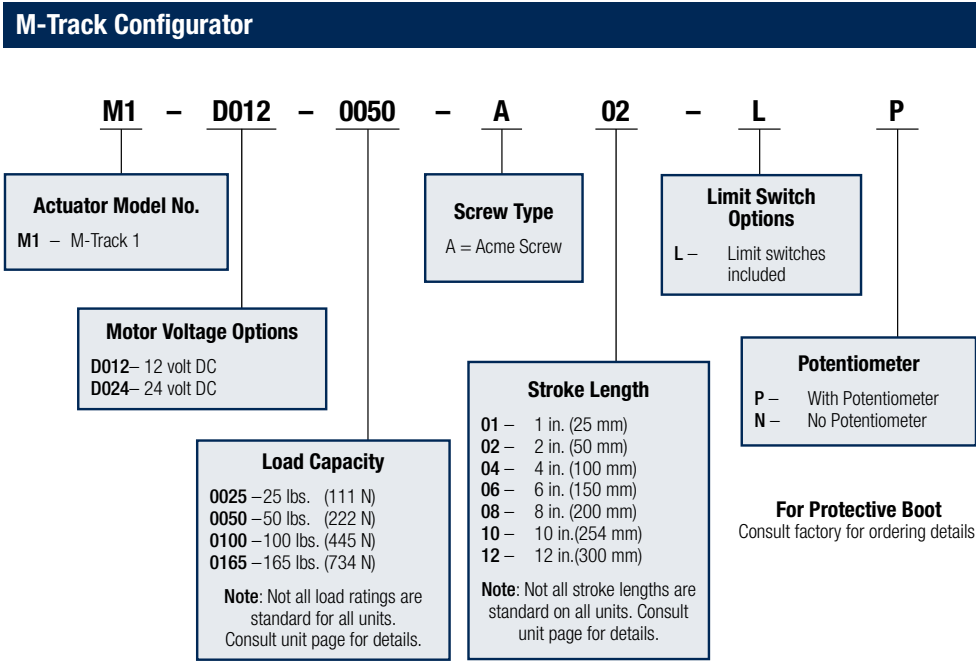

Scan to watch!
Linear Actuator Basic Selection Video
<https://p.widencdn.net/ydtpk6>