

Air Tube Disc Clutches and Brakes

Typical Applications

Wichita High Torque Clutch provides fast acceleration and long life on metalforming punch presses.

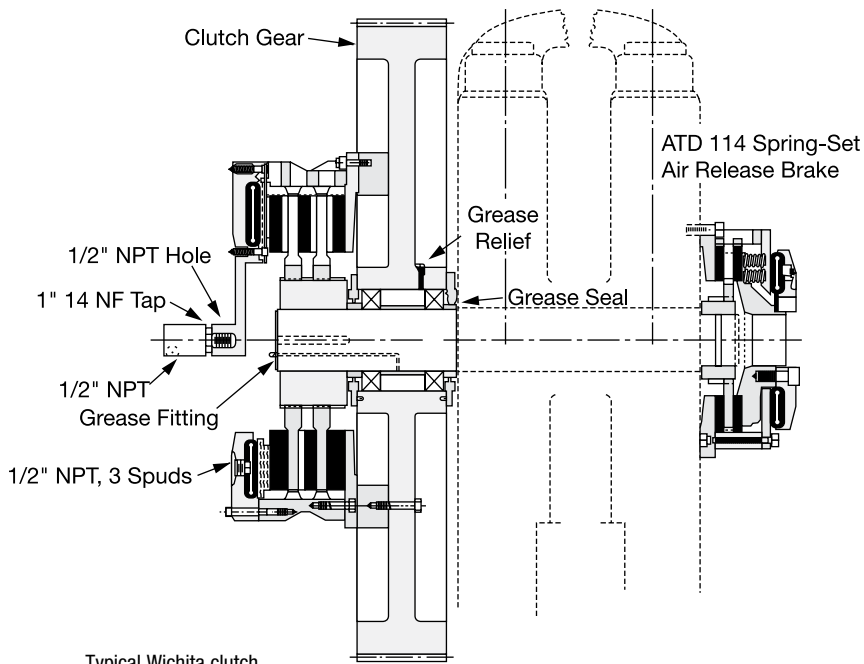
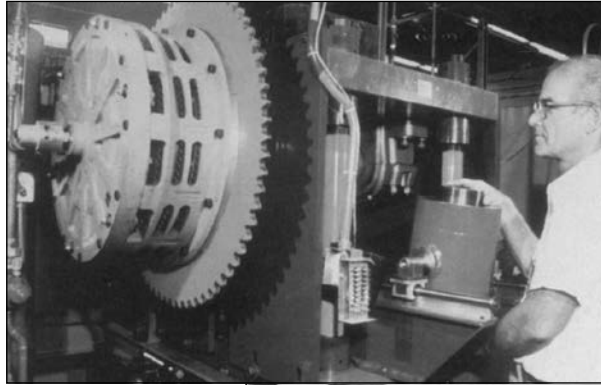

Typical Wichita clutch and brake mounting on a press

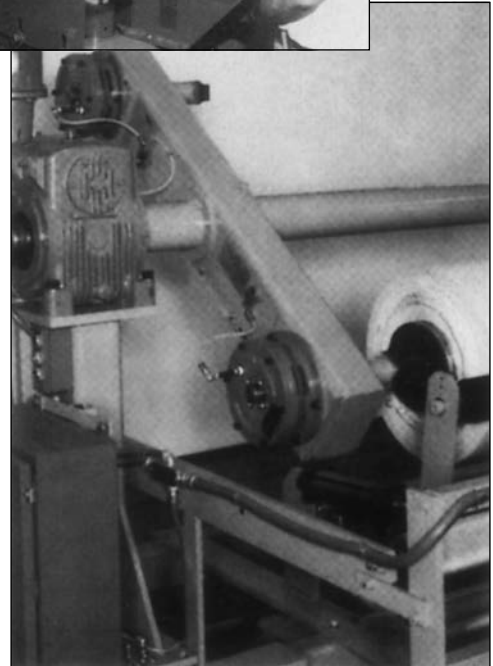

Wichita Low Inertia Brakes increase tension control for paper unwind stands.

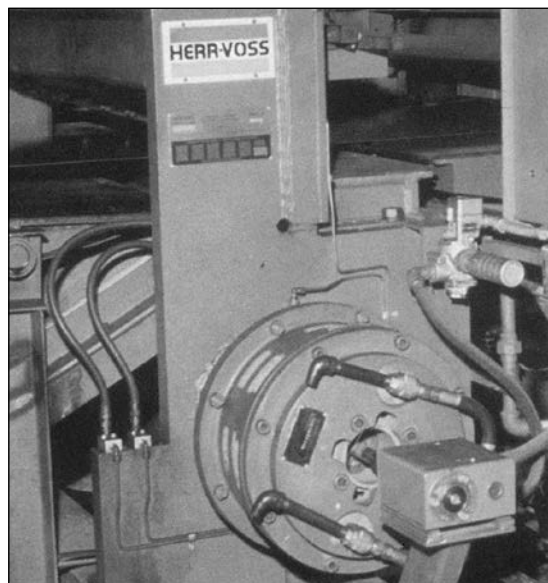

Wichita Spring-Set Air Release Brakes insure accuracy and high performance for a metal shear.



Air Tube Disc Clutches and Brakes

Application Factors

Clutch sizes are affected by the following variables:

1. Machines that operate under smooth loads require smaller clutches. These machines are driven by either multi-cylinder high speed engines or electric motors with reduced starting current.
2. Drives that require high starting current motors will require clutches with sufficient torque to prevent excessive slipping while starting.
3. Starting torque may be high, which requires a fast clutch response time to transmit the required torque; or, extended clutch slip time is required to protect the prime mover.
4. Starting torques may be very low compared to the normal torque, which may result in the clutch not being fully pressurized prior to the time of full torque requirement. This will cause the clutch to overheat from slippage. Clutch inflation time in this instance is very important.
5. Clutches on most machines are designed to slip prior to damage from shockloads. As a result, the clutch may require periodic maintenance; therefore, the clutch should be located for easy access in the power train. Clutches should also be located for maximum cooling air. In instances where this is not possible, forced air cooling may be necessary for extended clutch life.
6. Safe clutch operating speeds should be maintained in product design.

Maximum Clutch Contact Velocity FPM Material

6,000 (Recommended upper limit for slip).....	cast iron
9,000.....	ductile iron
12,000.....	steel

Dynamic balancing recommended when peripheral speeds exceed 3500 FPM. The maximum speeds shown are safe operating speeds based on years of Wichita testing. Please do not exceed these limits.

Application Guidelines

This chart gives application factors ranging from light duty (the A group) to extra heavy duty (the D group).

After initial usage is determined, see

“Selection Requirements” to complete the selection process. The inflation and exhaust time should also be checked to insure proper response.

Field of Application	Group A	Group B	Group C	Group D
Pumps		Centrifugal compressors	Reciprocating compressors over 2 cylinders, centrifugal fans & blowers	Reciprocating compressors one or two cylinders
Agitators	Liquid	Semi-solid	Solids	
Brick manufacturing			Brick press, extruder, pug mill	
Canning & bottling machine		Bottle-can feeders, filling, mixers		
Engine driven equipment			Crane, hoist, engine	Crowd
Grinding mills			Ball-rod-sag-pebble	Crushers, shakers
Lumber processing		Yarder	Carriages, conveyers	Chipper, logger
Marine		Propulsion clutch CP wheel	Shaft brakes, propulsion reversing type, anchor winch	
Bulk material handling	Conveyors evenly loaded, line shaft evenly loaded	Feeders	Elevators	
Metal production & metalforming		Coilers, slitters, press brake, non-gearred press, geared press	Draw bench, rolling mill, shear, back geared press, deep draw press, transfer press, toggle press	Hammer mill, forming press, forging press, header press, knuckle press
Paper industry dryer sections & calenders Consult factory			Fourdrinier to 500 FPM, paper mill plane & smoothing press	Fourdrinier to 1800 RPM press selections, calenders & dryers
Petroleum production		Drilling & service rig master clutches, compound clutches, rotary, drum		Mud pumps, PTO clutches
Rubber manufacturing	Transfer machines evenly loaded		Banberry mixer, drum mixer, extruder, calender	Centrifuge

Air Tube Disc Clutches and Brakes

Low Inertia and Very Low Inertia Clutches and Brakes

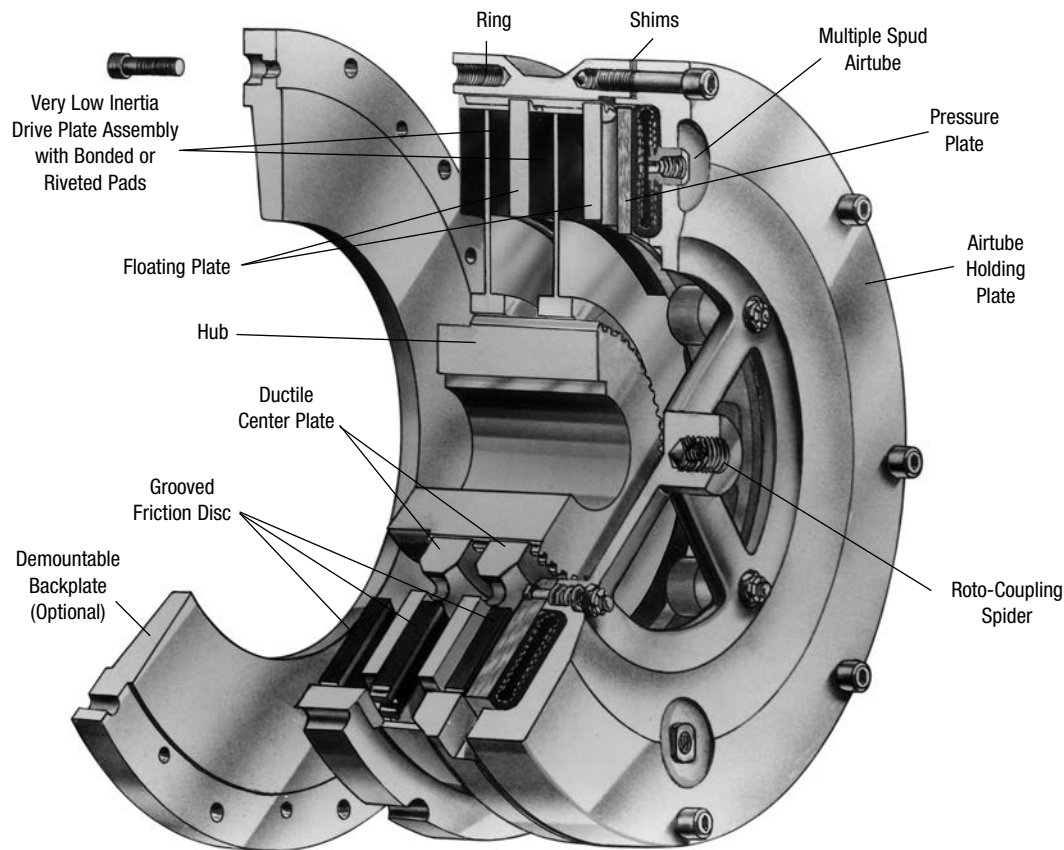

Operating Features

The Wichita Air-Tube Disc Clutch combines all the best features of the disc type clutch with all the advantages of direct air engagement. The simplest and most trouble-free method of applying air pressure is through direct axial pressure application by compressed air in a special composition full-circle tube.

Wichita Clutches engage smoothly without noise, shock or impact and release completely in a fraction of a second. Extremely fast action is possible because of the small volume of air required.

Clutches may be slipped moderately to control the acceleration rate.

When large inertia loads are powered from electric motors, smooth, controlled slip starts by Wichita Clutches can keep power demands below the allowed maximum.

Heat generated by controlled slipping or high cycle rate operation is dissipated by the centrifugal blower design of these units.

Wichita Low Inertia and Very Low Inertia Clutches and Brakes are designed to be completely free from effects of centrifugal force and self energization.

Torque developed is in direct proportion to air pressure applied.

These clutches and brakes interface well with automated controls through simple air and/or electric circuits.

Water cooled, copper disc clutches are available for use when power transmission needs require excessive or constant slipping which demands higher heat dissipation.

Wichita Clutches operate perfectly when teamed with Wichita Brakes in production situations requiring tension control, cyclic duty, or positioning.

Wichita Brakes have the same outstanding performance characteristics as Wichita Clutches.

Air Tube Disc Clutches and Brakes

Low Inertia and Very Low Inertia Clutches and Brakes

Selection Requirements

The selection of a Low Inertia Brake is based on:

1. Torque required to stop a load.
2. Friction area necessary to absorb rotational energy.
3. Contact velocity of rotating discs.
4. Maximum bore capacity of unit.

Selection example

To properly select a Low Inertia Brake for a controlled deceleration application, the following information is needed:

Speed 750 RPM
Shaft Dia.5 in.
Inertia to Stop.2,473 lb.ft.²
Stop Time.5 sec.
Air Pressure Available80 PSI

Calculations

$$\begin{aligned} \text{Avg. HP} &= \frac{WR^2 \times (\text{RPM})^2}{3.2 \times 10^6 \times \text{Stop Time}} \\ &= \frac{2,473 \times (750)^2}{3.2 \times 10^6 \times 5 \text{ sec.}} = 87 \text{ HP} \end{aligned}$$

$$\begin{aligned} \text{Swept Friction Area} &= \frac{\text{Avg. HP}}{\text{HP absorption rate for 5 seconds (see page 174)}} \\ &= \frac{87 \text{ HP}}{0.43} = 202 \text{ in.}^2 \end{aligned}$$

$$\begin{aligned} \text{Torque} &= \frac{WR^2 \times \text{RPM}}{25.5 \times \text{Stop Time}} \\ &= \frac{2,473 \times 750}{25.5 \times 5} \\ &= 14,547 \text{ lb.in.} \end{aligned}$$

Using the above calculations, consult the Low Inertia Specifications Chart on pages 26 and 27.

Summary

As calculated, the torque required to stop the load in 5 seconds is 14,547 lb.in. Wichita Low Inertia Brakes are rated at 100 PSI. This application has only 80 PSI available.

To determine the torque rating of a Low Inertia brake at 80 PSI apply the following formula:

Application: Torque for a Low Inertia Brake

$$\begin{aligned} &= \frac{\text{Torque X Catalog Rated Pressure}}{\text{Available Air Pressure}} \\ &= 14,547 \times \frac{100}{80} = 18,183 \text{ lb.in.} \end{aligned}$$

Consult pages 26 and 36 for clutch and brake specifications. A Low Inertia model 114 Brake produces 27,625 lb.in. torque at 100 PSI. However, the bore capacity is 4.125 inches. This application requires a 5 inch bore. Therefore, a Low Inertia 118 is to be investigated.

Catalog Torque Rating = 64, 500 lb.in @ 100 PSI
Maximum Bore Capacity = 5.25 in.
Catalog Swept Friction Area = 264 in.²

Calculations show this application needs at least 202 in.² to absorb the heat.

All of these ratings are acceptable for the given application data.

Next, check contact velocity of rotating discs.

$$\begin{aligned} &= \frac{\text{Diameter of center plate X RPM}}{3.82} \\ &= \frac{18" \times 750}{3.82} \\ &= 3,534 \text{ FPM} \end{aligned}$$

Standard material is sufficient up to 6,000 FPM (see page 23). Balancing is recommended above 3,500 FPM.

Therefore, a Low Inertia ATD-118 brake is the optimum choice for this application.

A Spring-Set Air Release Brake is also available (see page 58).

Note:

This application example is for preliminary sizing only. Contact a Wichita Sales Engineer or the factory for final selection.



Air Tube Disc Clutches and Brakes

Low Inertia Clutches

Specifications

Model Size ATD-	Assembly Number	Drawing Number	Slip Torque Capacity				Duty Factors				Max. Bore	
			lb.in.		Nm		HP/100 RPM				in.	(mm)
			80 PSI	100 PSI	5.5 BAR	7 BAR	A	B	C	D		
LIC 106	6-006-100-211-0	-100-900-9	3,160	3,950	340	435	6.2	4.4	2.2	1.1	2.00	(50)
LIC 206	6-006-200-200-0	-200-900-9	6,320	7,900	680	870	12.5	8.8	4.4	2.2		
LIC 108	6-008-100-103-0	D-1718	5,600	7,000	620	790	11.1	8	4	2	2.25	(57)
LIC 208	6-008-200-101-0	-200-900-9	11,200	14,000	1,240	1,580	22.2	16	8	4		
LIC 308	6-008-300-103-0	D-2843	16,800	21,000	1,865	2,375	33.3	24	12	6	2.50	(64)
LIC 111	6-011-100-102-0	-100-900-9	12,720	15,900	1,400	1,785	25	18	9	5		
LIC 211	6-011-200-102-0	-200-900-9	25,440	31,800	2,800	3,570	50	36	18	10		
LIC 311	6-011-300-100-0	B-322	38,160	47,700	4,235	5,390	75	54	27	15	3.50	(89)
LIC 114	6-014-100-102-0	-100-900-9	22,100	27,625	2,435	3,100	44	31	16	8		
LIC 214	6-014-200-104-0	-200-900-9	44,200	55,250	4,870	6,200	88	62	32	16		
LIC 314	6-014-300-100-0	B-329	66,300	82,875	7,355	9,365	132	93	48	24	4.00	(102)
LIC 116	6-016-100-100-0	D-327	30,270	37,838	3,360	4,275	60	46	24	12		
LIC 216	6-016-200-100-0	-200-900-9	60,541	75,676	6,720	8,550	120	92	48	24		
LIC 316	6-016-300-100-0	D-1205	90,811	113,514	10,080	12,825	180	139	72	36	4.75	(121)
LIC 118	6-018-100-100-0	-100-100-0	51,600	64,500	5,705	7,260	102	75	35	21		
LIC 218	6-018-200-100-0	-200-900-9	103,200	129,000	11,410	14,520	204	150	70	42		
LIC 318	6-018-300-101-0	D-680	154,840	193,550	17,115	21,780	306	225	105	63	6.00	(152)
LIC 121	6-021-100-100-0	D-127	69,887	87,359	7,755	9,870	139	107	55	28		
LIC 221	6-021-200-100-0	-200-900-9	139,775	174,719	15,510	19,740	277	213	111	55		
LIC 321	6-021-300-100-0	D-783	209,662	262,078	23,265	29,610	416	320	166	83	6.00	(152)
LIC 124H	6-025-100-100-0	D-347	122,960	153,700	13,575	17,275	243	180	90	40		
LIC 224H	6-025-200-100-0	-200-900-9	245,920	307,400	27,150	34,550	487	360	180	80		
LIC 324H	6-025-300-201-0	-300-900-9	368,880	461,100	40,725	51,825	729	540	270	120	6.50	(165)
LIC 127	6-027-100-100-0	-100-900-9	137,509	171,886	15,260	19,420	273	210	109	55		
LIC 227	6-027-200-100-0	-200-900-9	275,018	343,773	30,520	38,840	546	420	218	109		
LIC 327	6-027-300-100-0	D-689	412,527	515,659	45,780	58,260	819	630	327	164	7.25	(184)
LIC 130H	6-031-100-100-0	B-195	261,600	327,000	29,630	37,710	519	380	190	100		
LIC 230H	6-031-200-349-0	-200-900-9	523,200	654,000	59,260	75,420	1,038	760	380	200		
LIC 330H	6-031-300-104-0	-300-902-9	784,800	981,000	88,890	113,130	1,557	1,140	570	300	9.00	(229)
LIC 136	6-036-100-100-0	-100-900-9	406,400	508,000	44,920	57,175	805	600	295	165		
LIC 236	6-036-200-100-0	D-570	812,800	1,016,000	89,840	114,350	1,610	1,200	590	330		
LIC 336	6-036-300-100-0	-300-900-9	1,219,200	1,524,000	134,760	171,525	2,415	1,800	885	495	14.00	(355)
LIC 142	6-042-100-303-0	-100-900-9	580,800	726,000	69,160	81,660	1,150	850	425	235		
LIC 242	6-042-200-309-0	-200-900-9	1,162,240	1,452,800	128,320	163,320	2,300	1,700	850	470		
LIC 342	6-042-300-302-0	-300-303-9	1,742,400	2,178,000	192,480	244,980	3,450	2,550	1,275	705	18.00	(455)
LIC 148	6-048-100-300-0	-100-901-9	1,122,000	1,402,500	118,800	151,200	2,225	1,600	800	455		
LIC 248	6-048-200-300-0	-200-906-9	2,244,000	2,805,000	237,600	302,400	4,450	3,200	1,600	915		
LIC 348	6-048-300-110-0	-300-900-9	3,366,000	4,207,500	356,400	453,600	6,675	4,800	2,400	1,365	19.00	(480)
LIC 260	6-060-200-302-0	-200-907-9	4,760,000	5,950,000	473,000	602,000	9,440	5,950	3,470	1,940		
LIC 360	6-060-300-201-0	-300-901-9	7,140,000	8,925,000	709,000	902,300	14,160	8,925	5,205	2,910		
LIC 460	6-060-400-300-0	E-236	14,280,000	17,850,000	946,000	1,204,000	18,880	11,900	6,940	3,880		

Maximum Air Pressure is 130 PSI / 9 BAR.

Air Tube Disc Clutches and Brakes

Low Inertia Clutches Specifications

Model Size ATD-	Recom- mended Clearance in.	Balance Speed RPM	Airtube Type		Swept Area in. ²	Airtube Volume in. ³ /(cm ³)		Total Clutch				Hub & Center Plate			
			Reg- Speed RPM	High Speed RPM*		New	Worn	Wt.		WR ² / J=mr ²		Wt.		WR ² / J=mr ²	
								lb.	(kg)	lb.ft. ²	(kgm ²)	lb.	(kg)	lb.ft. ²	(kgm ²)
LIC 106	1/16-3/32			2,600*	39	1.8	11.9	27.5	(12)	2.5	(0.105)	6.40	(2.9)	0.24	(0.010)
LIC 206	3/32-5/32	2,225	1,800		78	(30)	(195)	40.5	(18)	3.3	(0.139)	12.17	(5.5)	0.46	(0.019)
LIC 108	1/16-1/8				56			62	(28)	7.5	(0.315)	11	(5.0)	0.54	(0.023)
LIC 208	3/32-5/32	1,675	1,750	3,000*	112	3.4	18.3	70	(32)	8.5	(0.357)	19	(8.6)	1.00	(0.042)
LIC 308	1/8-3/16				168	(56)	(300)	92	(42)	99	(4.174)	28	(12.7)	2.00	(0.084)
LIC 111	1/16-1/8				114			133	(60)	27	(1.14)	23	(10.4)	2.30	(0.097)
LIC 211	3/32-5/32	1,200	1,400	2,800*	228	5.5	30.5	170	(77)	34	(1.43)	45	(20.4)	4.50	(0.190)
LIC 311	1/8-3/16				342	(90)	(500)	208	(94)	52	(2.19)	121	(54.9)	7.00	(0.295)
LIC 114	1/16-1/8				158			184	(83)	56	(2.36)	46	(20.9)	5.7	(0.240)
LIC 214	3/32-5/32	950	1,200	2,200*	316	7.6	42.7	233	(106)	70	(2.95)	77	(34.9)	11.0	(0.464)
LIC 314	1/8-3/16				474	(125)	(700)	292	(132)	80	(3.37)	121	(54.9)	16.7	(0.704)
LIC 116	1/16-1/8				228			257	(117)	103	(4.34)	59	(26.8)	10.2	(0.430)
LIC 216	3/32-5/32	835	1,200	2,000*	455	9.8	56.1	326	(148)	125	(5.27)	106	(48.1)	19.6	(0.826)
LIC 316	1/8-3/16				683	(161)	(919)	358	(162)	125	(5.27)	151	(68.5)	29.6	(1.248)
LIC 118	1/16-1/8				264			311	(141)	158	(6.66)	73	(33.1)	15.0	(0.632)
LIC 218	3/32-5/32	750	1,000	2,000*	528	15.3	85.4	377	(171)	183	(7.72)	120	(54.4)	28.8	(1.214)
LIC 318	1/8-3/16				792	(251)	(1,400)	472	(214)	219	(9.23)	180	(81.6)	43.2	(1.821)
LIC 121	3/32-5/32				362			467	(212)	303	(12.77)	116	(52.6)	32	(1.35)
LIC 221	1/8-3/16	650	900	1,650*	724	18.3	97.6	582	(264)	356	(15.01)	198	(89.8)	61	(2.57)
LIC 321	5/32-7/32				1,086	(300)	(1,599)	730	(331)	450	(18.97)	272	(123.4)	92	(3.88)
LIC 124H	3/32-5/32				574			637	(289)	468	(19.73)	132	(60.0)	56	(2.4)
LIC 224H	1/8-3/16	550	700	1,400*	1,148	29.9	159	830	(376)	618	(26.05)	260	(117.9)	109	(4.6)
LIC 324H	5/32-7/32				1,722	(490)	(2,606)	1,025	(465)	735	(31.00)	379	(172.0)	160	(6.8)
LIC 127	3/32-5/32				730			770	(349)	706	(29.8)	187	(84.8)	98	(4.1)
LIC 227	1/8-3/16	500	700	1,400*	1,460	29.9	159	950	(431)	862	(36.3)	322	(146.1)	193	(8.1)
LIC 327	5/32-7/32				2,190	(490)	(2,606)	1,112	(504)	969	(40.9)	555	(251.7)	285	(12.0)
LIC 130H	3/32-5/32				827			1,035	(469)	1,170	(49.3)	298	(135.2)	189	(8.0)
LIC 230H	1/8-3/16	450	600	1,100*	1,654	58.6	311	1,411	(640)	1,552	(65.4)	546	(247.7)	370	(15.6)
LIC 330H	5/32-7/32				2,481	(960)	(5,096)	1,751	(794)	1,788	(75.4)	810	(367.4)	477	(20.1)
LIC 136	3/32-5/32				1,150			1,455	(660)	2,368	(99.8)	461	(209.1)	372	(15.7)
LIC 236	1/8-3/16	375	600	900*	2,300	110	415	1,992	(904)	3,247	(136.9)	708	(321.1)	725	(30.6)
LIC 336	5/32-7/32				3,450	(1,803)	(6,801)	2,610	(1,184)	4,057	(171.0)	1,134	(514.4)	1,091	(46.0)
LIC 142	5/32-7/32				1,400			1,967	(892)	4,721	(199)	680	(308)	705	(30)
LIC 242	3/16-1/4	325	500	800*	2,800	128	488	2,732	(1,239)	5,750	(242)	1,197	(543)	1,385	(58)
LIC 342	7/32-9/32				4,200	(2,098)	(7,997)	3,704	(1,680)	9,191	(387)	1,324	(601)	1,809	(76)
LIC 148	1/8-1/4				2,010			3,158	(1,432)	9,325	(393)	1,101	(499)	1,785	(75)
LIC 248	5/32-7/32	275	400	700*	4,020	217	824	4,700	(2,132)	13,775	(581)	1,942	(881)	3,335	(141)
LIC 348	3/16-5/16				6,030	(3,550)	(13,500)	6,540	(2,966)	18,000	(759)	2,950	(1,338)	4,925	(208)
LIC 260	3/16-5/16				7,230			9,453	(4,288)	48,733	(2,055)	2,567	(1,164)	7,077	(298)
LIC 360	1/4-3/8	225	320	550*	10,845	513	1,788	11,643	(5,281)	57,286	(2,415)	3,870	(1,755)	10,615	(448)
LIC 460	5/16-7/16				14,460	(8,407)	(29,300)	14,500	(6,577)	68,980	(2,908)	5,700	(2,585)	15,070	(635)

* Consult Factory for Special Assembly Number.

Air Tube Disc Clutches and Brakes

Air System Data

PSI pressure

Inflation

Clutch air pressure during inflation can be closely estimated by the following:

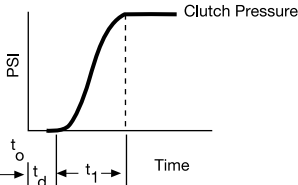

$$t_1 = \left(\frac{3}{K}\right)^{\frac{1}{U}} \text{ sec.} = \text{Time to 95\% Full Inflation}$$

$$\text{Clutch pressure} = P_1 \left(1 - \frac{1}{e^{Kt^U}}\right) \text{ PSI (inflation)}$$

This equation is accurate from 5% up to 95% P_1 .

P_1 = Line pressure to clutch PSI

K and U = coefficients for specific clutch and air pressure from Specification Table

e = Napierian base log

t_o = Time at initiation of signal for inflation sec.

t_d = Time delay of air system – sec.

Exhaust

Clutch air pressure during exhaust can be closely estimated by the following:

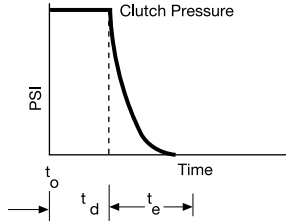

$$\text{Clutch pressure} = (P_1) (R) (E-t)^V \text{ PSI (exhaust)}$$

R , E and V = coefficients for specific clutch and air pressure from Specification Table

t_e = Time to exhaust = E from Specification Table

t = Time variable – seconds. In the exhaust equation “ t ” cannot exceed the value of “ E ” sec.

Overlap

A typical clutch-brake torque curve for a single backshaft press (cyclic application) would appear as shown below.

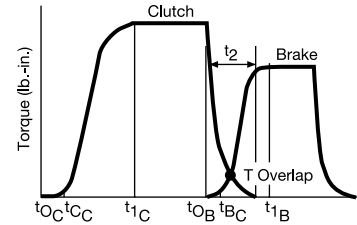

Time (sec.)

t_{0C} = time at which disengaged clutch receives signal

t_{0B} = time at which disengaged brake receives signal

t_{1C} = time of clutch full inflation

t_{1B} = time of brake full exhaust

t_{2} = overlap time at which clutch and brake are both engaged

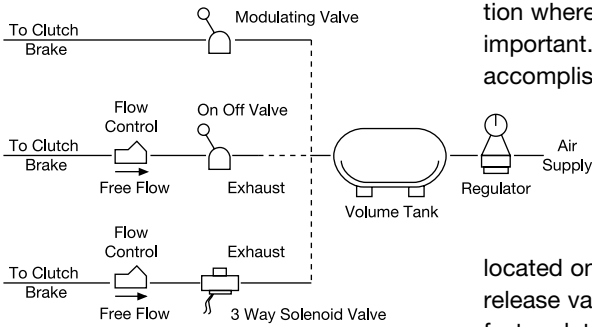

Shown are some of the air systems used on Wichita clutches. These systems are acceptable for remote operation where clutch reaction time is not important. Faster clutch reaction time is accomplished as indicated in the diagram by locating the flow control valve, if required, and the solenoid valve as close as possible to the roto-coupling. Where clutches are located on long shafts, the use of quick release valves on the clutch will facilitate faster clutch response.

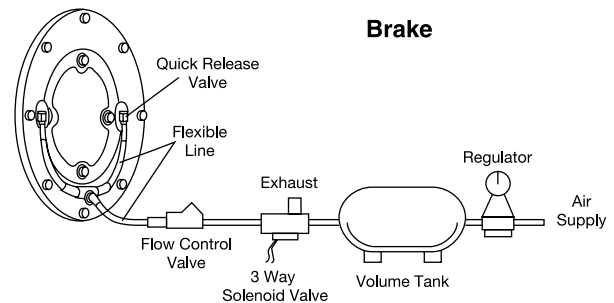
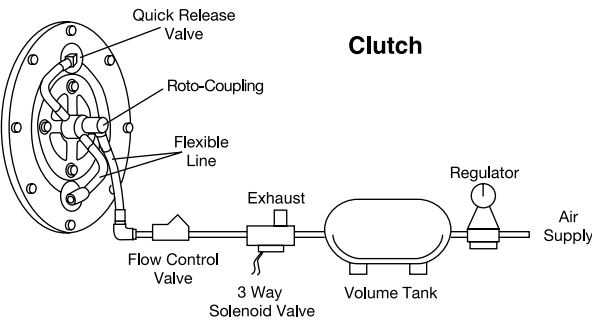

Air Tube Disc Clutches and Brakes

Low Inertia and Very Low Inertia Clutches and Brakes

Inflation Coefficients

Model Size ATD-	Inflation Coefficients Operating Air Pressure					
	50 PSI		75 PSI		100 PSI	
	K	U	K	U	K	U
108	15,800	2.2	7,100	2	265	1.2
208	15,800	2.2	7,100	2	265	1.2
111	890	1.7	880	1.6	5,100	2.2
211	890	1.7	880	1.6	5,100	2.2
114	980	2.3	980	2.3	980	2.3
214	980	2.3	980	2.3	980	2.3
118	9,600	3.1	1,560	2.4	9,600	3.1
218	9,600	3.1	1,560	2.4	9,600	3.1
124H	145	1.8	90	1.6	87	1.6
224H	145	1.8	90	1.6	87	1.6
130H	185	2	150	2	93	1.8
230H	185	2	150	2	93	1.8
136	170	2	250	2.2	160	2
236	170	2	250	2.2	160	2
142	115	2	125	2	111	2
242	115	2	125	2	111	2
148	25	1.6	22	1.6	26	1.8
248	25	1.6	22	1.6	26	1.8
260	28	1.8	22	1.8	20	1.8
360	28	1.8	22	1.8	20	1.8

Exhaust Coefficients

Model Size ATD-	Exhaust Coefficients Operating Air Pressure								
	50 PSI			75 PSI			100 PSI		
	R	E	V	R	E	V	R	E	V
108	60	.016	1.0	525	.02	1.6	240	.02	1.4
208	60	.016	1.0	525	.02	1.6	240	.02	1.4
111	1,000	.032	2	8,200	.04	2.8	4,930	.048	2.8
211	1,000	.032	2	8,200	.04	2.8	4,930	.048	2.8
114	720	.072	2.5	800	.069	2.5	1,840	.082	3
214	720	.072	2.5	800	.069	2.5	1,840	.082	3
118	44	.068	1.4	40	.072	1.4	34	.08	1.4
218	44	.068	1.4	40	.072	1.4	34	.08	1.4
124H	360	.096	2.5	240	.112	2.5	270	.136	2.8
224H	360	.096	2.5	240	.112	2.5	270	.136	2.8
130H	120	.104	2.1	140	.128	2.4	146	.158	2.7
230H	120	.104	2.1	140	.128	2.4	146	.158	2.7
136	124	.112	2.2	92	.128	2.2	76	.152	2.3
236	124	.112	2.2	92	.128	2.2	76	.152	2.3
142	132	.12	2.3	89	.144	2.3	61	.168	2.3
242	132	.12	2.3	89	.144	2.3	61	.168	2.3
148	20	.224	2	20	.256	2.2	19	.308	2.5
248	20	.224	2	20	.256	2.2	19	.308	2.5
260	24	.264	2.4	10	.367	2.3	9.9	.352	2.2
360	24	.264	2.4	10	.367	2.3	9.9	.352	2.2

Air Tube Disc Clutches and Brakes

Low Inertia Clutches

Sizes 8-36

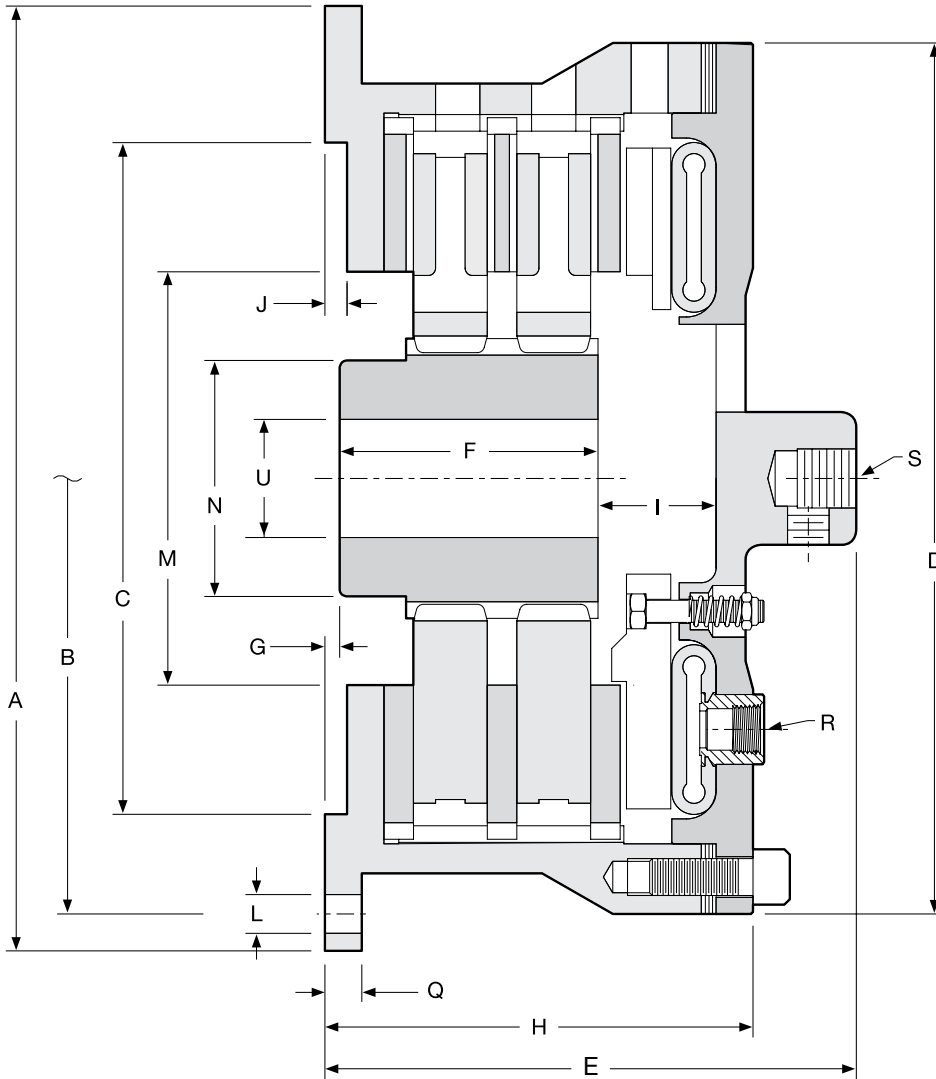

Air Tube Disc Clutches and Brakes

Low Inertia Clutches

Sizes 8-36

Dimensions: inches (mm)

Model Size ATD-	A	B Hole Circle	C Pilot	D	E	F	G	H
LIC 108	12.13	11.125	8.375 / 8.378	11.13	6.31 (160.3)	2.00 (50.8)	.25 (6.4)	4.56 (115.8)
LIC 208	(308.1)	(282.58)	(212.73 / 212.80)	(282.7)	7.69 (195.3)	3.25 (82.6)	.31 (7.9)	5.94 (150.9)
LIC 111	16.00	14.750	11.375 / 11.378	14.75	7.25 (184.2)	2.75 (69.9)	.13 (3.3)	5.50 (139.7)
LIC 211	(406.4)	(374.65)	(288.93 / 289.00)	(374.7)	9.00 (228.6)	4.38 (111.3)	.25 (6.4)	7.25 (184.2)
LIC 114	18.75	17.500	14.375 / 14.378	17.50	7.56 (192.0)	3.75 (95.3)	.13 (3.3)	6.06 (153.9)
LIC 214	(476.3)	(444.50)	(365.13 / 365.20)	(444.5)	9.38 (238.3)	4.50 (114.3)	.38 (9.7)	7.88 (200.2)
LIC 116					7.81 (198.4)	4.00 (101.6)		6.31 (160.3)
LIC 216	21.25	20.000	16.250 / 16.253	20.00	9.75 (247.7)	4.75 (120.7)	.38 (9.7)	8.25 (209.6)
LIC 316	(539.8)	(508.00)	(412.75 / 412.83)	(508.0)	11.69 (296.9)	6.63 (168.4)		10.19 (258.8)
LIC 118					8.19 (208.0)	4.00 (101.6)		6.69 (169.9)
LIC 218	23.25	22.000	18.250 / 18.253	22.00	10.13 (257.3)	4.75 (120.7)	.44 (11.2)	8.63 (219.2)
LIC 318	(590.6)	(558.80)	(463.55 / 463.63)	(558.8)	12.13 (308.1)	6.50 (165.1)		10.63 (270.0)
LIC 121					8.88 (225.6)	4.00 (101.6)	.75 (19.1)	7.38 (187.5)
LIC 221	27.00	25.500	21.375 / 21.378	24.88	10.94 (277.9)	5.13 (130.3)	.63 (16.0)	9.44 (239.8)
LIC 321	(685.8)	(647.70)	(542.93 / 543.00)	(632.0)	13.25 (336.6)	7.13 (181.1)	.75 (19.1)	11.75 (298.5)
LIC 124H					9.13 (231.9)	4.00 (101.6)	.69 (17.5)	7.63 (193.8)
LIC 224H	30.00	28.750	24.375 / 24.378	29.00	11.38 (289.1)	5.13 (130.3)	.75 (19.1)	9.88 (251.0)
LIC 324H	(762)	(730.25)	(619.13 / 619.20)	(736.6)	13.75 (349.3)	7.50 (190.5)	.75 (19.1)	12.25 (311.2)
LIC 127					9.38 (238.3)	4.50 (114.3)	.75 (19.1)	7.88 (200.2)
LIC 227	32.75	31.500	27.375 / 27.378	31.00	11.88 (301.8)	6.88 (174.8)		10.38 (263.7)
LIC 327	(831.9)	(800.10)	(695.33 / 695.40)	(787.4)	—	—	—	—
LIC 130H					12.5	5.00 (127.0)	.63 (16.0)	8.25 (209.6)
LIC 230H	37.00	35.500	30.375 / 30.3783	34.75	15.94	7.13 (181.1)	1.88 (47.8)	11.69 (296.9)
LIC 330H	(939.8)	(901.70)	(771.53 / 771.60)	(882.7)	—	—	—	—
LIC 136					12.94 (328.7)	5.63 (143.0)		9.44 (239.8)
LIC 236	43.50	42.000	36.375 / 36.378	41.00	16.63 (422.4)	9.00 (228.6)	.63 (16.0)	12.75 (323.9)
LIC 336	(1,104.9)	(1,066.80)	(923.93 / 924.00)	(1,041.4)	19.88 (505.0)	12.38 (314.5)		16.38 (416.1)

Dimensions: inches (mm)

Model Size ATD-	I	J	L		M	N	Q	R		S	U	
			No. -	Size				No. -	Size		Min.	Max.
LIC 108	1.78 (45.2)	.25			5.38	3.50	.50				1.00	2.00
LIC 208	1.88 (47.8)	(6.4)	6 -	17/32 (13.5)	(136.7)	(88.9)	(12.7)	2 -	1/2 NPT	1"-14NF	(25)	(50.8)
LIC 111		.38	6 -	11/16 (17.5)	7.00	4.00	.63	2 -	1/2 NPT	1"-14NF	1.00	2.50
LIC 211	2.00 (50.8)	(9.7)	6 -	21/32 (16.7)	(177.8)	(101.6)	(16.0)				(25)	(63.5)
LIC 114	1.44 (36.6)	.38	8 -	21/32 (16.7)	9.44	5.50	.63	2 -	1/2 NPT	1"-14NF	1.38	3.50
LIC 214	2.13 (54.1)	(9.7)	8 -	21/32 (16.7)	(239.8)	(139.7)	(16.0)				(35.1)	(88.9)
LIC 116	1.13 (28.7)											
LIC 216	2.31 (58.7)	.38	12 -	21/32 (16.7)	10.50	6.00	.63	2 -	1/2 NPT	1"-14NF	1.38	4.00
LIC 316	2.31 (58.7)	(9.7)	12 -	21/32 (16.7)	(266.7)	(152.4)	(16.0)				(35.1)	(101.6)
LIC 118	1.25 (31.8)											
LIC 218	2.50 (63.5)	.38	12 -	21/32 (16.7)	12.50	7.00	.63	3 -	1/2 NPT	1"-14NF	2.00	4.75
LIC 318	2.75 (69.9)	(9.7)	12 -	21/32 (16.7)	(317.5)	(177.8)	(16.0)				(50.8)	(120.7)
LIC 121	1.63 (41.4)											
LIC 221	2.68 (68.1)	.31	12 -	21/32 (16.7)	14.50	9.00	.75	3 -	1/2 NPT	1"-14NF	2.00	6.00
LIC 321	2.75 (69.9)	(7.9)	12 -	21/32 (16.7)	(368.3)	(228.6)	(19.1)				(50.8)	(152.4)
LIC 124H	1.75 (44.5)											
LIC 224H	2.94 (74.7)	.25	12 -	21/32 (16.7)	14.50	9.00	.75	3 -	1/2 NPT	1"-14NF	2.00	6.00
LIC 324H	2.88 (73.2)	(6.4)	12 -	21/32 (16.7)	(368.3)	(228.6)	(19.1)				(50.8)	(152.4)
LIC 127	1.38 (35.1)	.25										
LIC 227	1.50 (38.1)	(6.4)	16 -	21/32 (16.7)	16.25	9.00	.75	3 -	1/2 NPT	1"-14NF	2.50	6.50
LIC 327	—	—	16 -	21/32 (16.7)	(412.8)	(228.6)	(19.1)				(63.5)	(165.1)
LIC 130H	1.81 (46.0)											
LIC 230H	1.88 (47.8)	.25	18 -	25/32 (19.8)	19.25	10.00	.75	4 -	1/2 NPT	1" NPT	2.50	7.25
LIC 330H	—	(6.4)	18 -	25/32 (19.8)	(489)	(254)	(19.1)				(63.5)	(184.2)
LIC 136	1.38 (35.1)											
LIC 236	1.63 (41.4)	.25	18 -	25/32 (19.8)	23.63	12.00	.88	4 -	1/2 NPT	1" NPT	6.00	9.00
LIC 336	1.75 (44.5)	(6.4)	18 -	25/32 (19.8)	(600.2)	(304.8)	(22.4)				(152.4)	(228.6)

Note: For mounting, use socket head capscrews conforming to the ASTM-574-97a. (Consult factory for drawing before final layout.)

Air Tube Disc Clutches and Brakes

Low Inertia Clutches

Sizes 6, 42-60

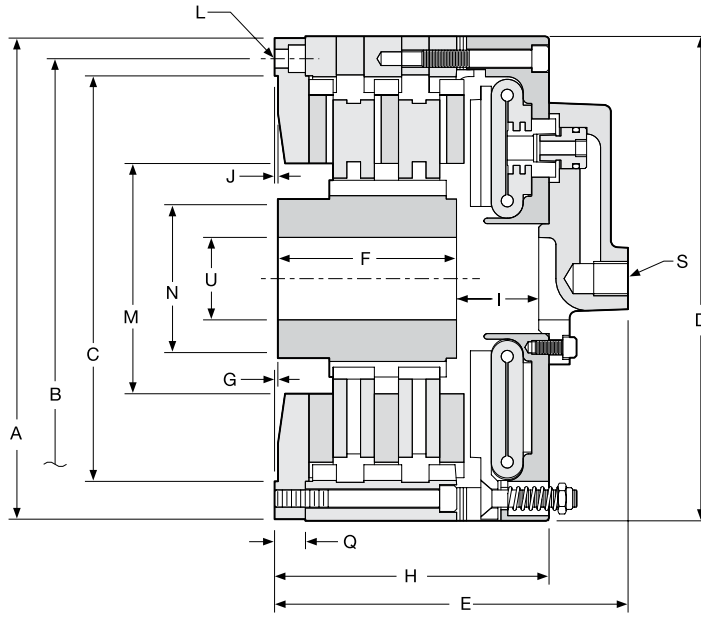

Size 6

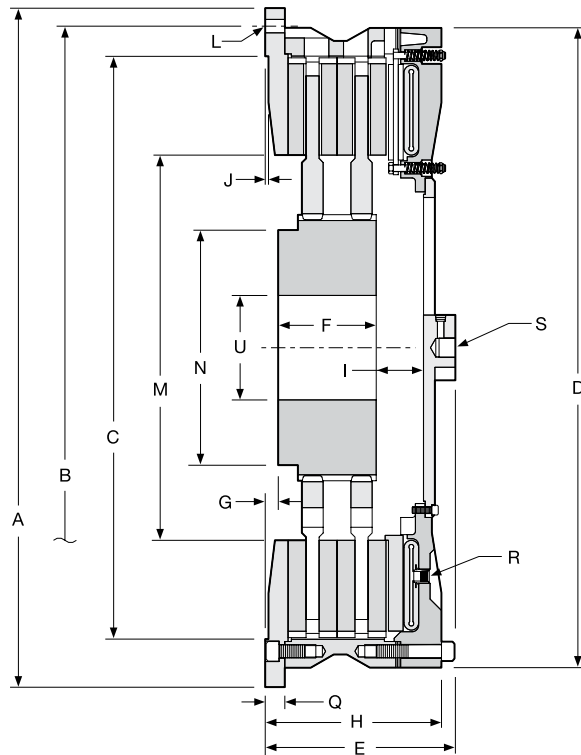

Size 42-60

Air Tube Disc Clutches and Brakes

Low Inertia Clutches

Sizes 6, 42-60

Dimensions: inches (mm)

Model Size ATD-	A	B Hole Circle	C Pilot	D	E	F	G	H
LIC 106	8.75	8.000	7.377 / 7.379	8.81	5.19 (131.8)	2.00 (50.8)	0.00 (0.0)	3.75 (95.3)
LIC 206	(222.3)	(203.20)	(187.38 / 187.43)	(223.8)	6.43 (163.3)	3.25 (82.6)	0.06 (1.5)	5.00 (127.0)
LIC 142	52.00	49.250	44.625 / 44.628	49.00	10.81 (274.6)	5.63 (143.0)	1.00 (25.40)	9.75 (247.7)
LIC 242	(1,320.8)	(1,250.95)	(1,133.48 / 1,133.55)	(1,244.6)	14.56 (369.8)	7.50 (190.5)		13.5 (342.9)
LIC 148	61.00	58.000	52.000 / 52.005	56.75	14.69 (373.1)	6.00 (152.4)	0.00 (0.0)	10.69 (271.5)
LIC 248	(1,549.4)	(1,473.20)	(1,320.80 / 1,320.93)	(1,441.5)	19.07 (484.4)	8.75 (222.3)	1.00 (25.4)	15.07 (382.8)
LIC 260 ¹					20.30 (515.6)	9.38 (238.3)	0.25 (6.4)	17.99 (456.9)
LIC 360 ¹	70.50	66.500	62.750 / 62.760	70.50	22.00 (558.8)	12.25 (311.2)	0.00 (0.0)	19.63 (498.6)
LIC 460 ¹	(1,790.7)	(1,689.10)	(1,593.85 / 1,594.10)	(1,790.7)	28.25 (717.6)	18.63 (473.2)	0.25 (6.4)	27.13 (689.1)

Dimensions: inches (mm)

Model Size ATD-	I	J	L		M	N	Q	R		S	U	
			No.-	Size				No. -	Size		Min.	Max.
LIC 106	1.56 (39.6)	0.06	4 -	0.34 (8.6)	4.19	2.69	0.56	—	5/8"-11NF	0.60	2.00	
LIC 206	1.50 (38.1)	(1.5)			(106.4)	(68.3)	(14.2)			(15.2)	(50.8)	
LIC 142	1.75 (44.5)	0.25	24 -	1.06 (26.9)	29.50	18.00	1.50	4 - 1/2 NPT	1.5"-12NF	8.00	14.00	
LIC 242	3.63 (92.2)	(6.4)			(749.3)	(457.2)	(38.1)			(203.2)	(355.6)	
LIC 148	3.69 (93.7)	0.25	24 -	1.06 (26.9)	32.00	25.75	1.50	4 - 1/2 NPT	1" NPT	10.00	18.00	
LIC 248	4.32 (109.7)	(6.4)			(812.8)	(654.1)	(38.1)			(254.0)	(457.2)	
LIC 260 ¹	6.17 (156.7)											
LIC 360 ¹	5.19 (131.8)	0.25	24 -	4.5"NC	36.00	27.00	—	6 - 1/2 NPT	2"-12NF	11.00	19.00	
LIC 460 ¹	6.38 (162.1)	(6.4)			(914.4)	(685.8)				(279.4)	(482.6)	

¹Less backplate.

NOTE: For mounting, use socket head capscrews conforming to the ASTM-574-97a.
(Consult factory for drawing before final layout.)

Air Tube Disc Clutches and Brakes

Low Inertia Clutch Air Hose Kits

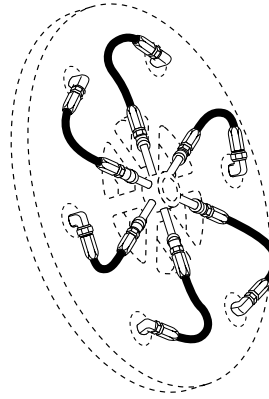
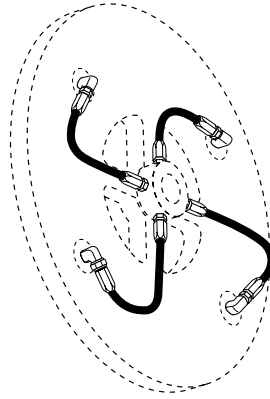
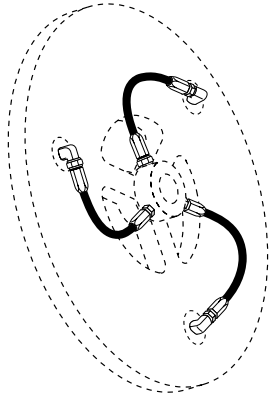
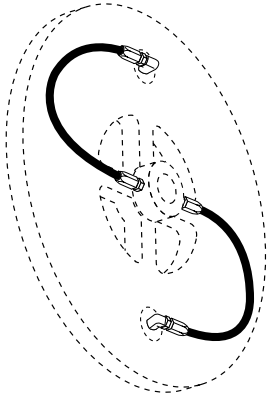

Size	Part Number
8"	8-908-812-200-5 8-908-821-201-5 QRV
11"	8-911-812-201-5 8-911-821-201-5 QRV
14"	8-914-812-200-5 8-914-821-200-5 QRV

Size	Part Number
18"	8-918-812-301-5 8-918-821-300-5 QRV
24"H	8-924-812-300-5 8-924-821-301-5 QRV

Size	Part Number
30"	8-930-812-400-5 8-930-821-400-5 QRV
36"	8-936-821-400-5 QRV
42"	8-942-821-400-5 QRV
48"	8-948-821-400-5 QRV

Size	Part Number
60"	8-960-800-500-7 QRV

Air hose kits contain all necessary parts (fittings, hoses and extensions) to completely plumb the clutch air system.

Optional Quick Release Valves can replace elbows on most units (see page 35).

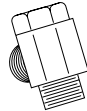

Roto-couplings (see page 35).



Air Tube Disc Clutches and Brakes

Quick Release Valve

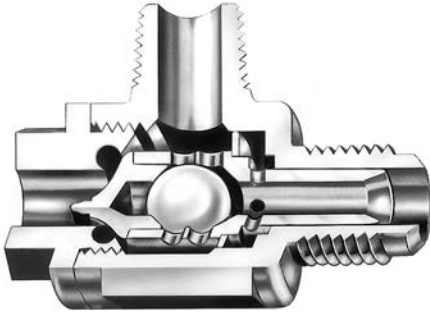

8-263-610-011-1 7/8" – 14 Thread
 8-263-610-021-1 1/2" NPT
 4-263-605-002-0 Optional Muffler

The Wichita Springless Quick Release Valve discharges twice as fast as any other valve tested in our laboratory and is four to five times faster than some common makes of valves.

This valve will close and seal with less than 20 lbs. pressure. Most others require 25 to 30 lbs. to definitely seal. In actual tests, the Wichita Valve made many hundreds of thousands of engagements and disengagements before the slightest leak occurred, or any parts needed replacement. Other valves which were tested required major replacement in fewer than 20,000 cycles.

Quality Material

Body and Cap: High strength aluminum alloy
 Stem: Molded nylon
 Check Valve: Nylon ball
 "O" Ring: Neoprene

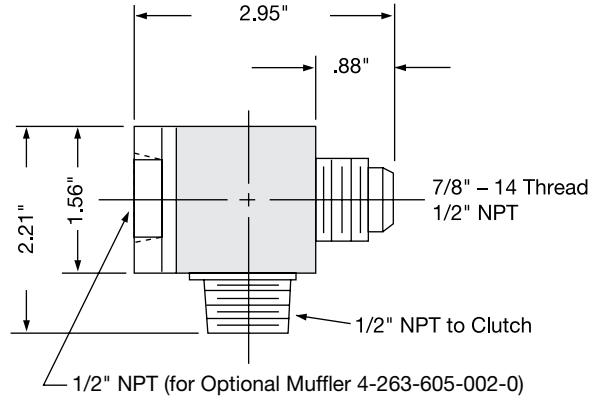

Standard thread arrangement of 1/2" size. 1/2" pipe thread on the tube connection and choice of 1/2" pipe thread, or standard 7/8-14NF thread for flared fitting thread on inlet connection. (Fits standard No. 10 high-pressure hose fitting.)

Roto-couplings

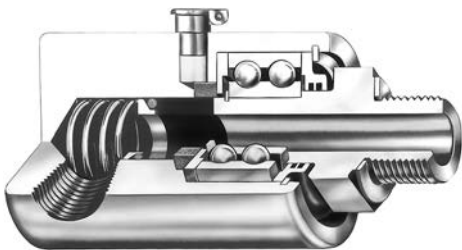

The Wichita Roto-coupling is a device to connect, or couple, a non-rotating air, gas, or fluid line to a rotating shaft.

- Long life, no maintenance.
- Felt seal eliminates bearing contamination.
- Fast, easy installation.

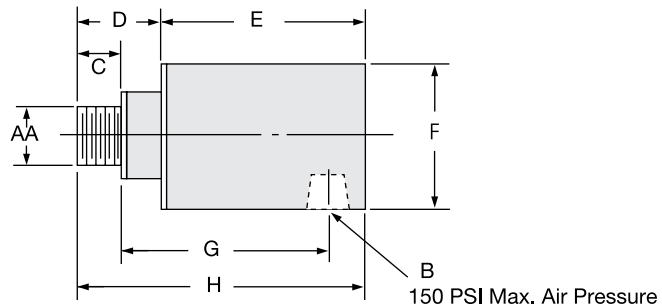

Dimensions: inches

Wichita Part No.	AA	B	C	D	E	F	G	H	Max. RPM
8-240-701-003-1	5/8-18NF	1/4" NPT	.40	1.046	2.250	1.500	2.13	3.297	3500
8-240-705-001-1	1"-14 NF	1/2" NPT	.75	1.250	3.188	2.500	3.00	4.438	3500
8-240-708-001-1	1"-14 NF	3/4" NPT	.75	1.313	4.688	2.875	3.69	5.440	3500
8-240-710-002-1	1-1/2"-12 NF	1" NPT	1.13	1.937	4.875	3.250	3.44	6.812	2500
8-240-712-001-1	2"-12 NF	1-1/2" NPT	1.13	2.813	5.250	4.250	5.38	8.062	2500
8-240-714-001-3	2" NPT	2" NPT	1.50	3.000	7.062	4.625	7.00	10.062	1000
8-240-716-000-3	2-1/2" NPT	2-1/2" NPT	1.88	3.250	9.375	7.000	7.75	12.625	750



Air Tube Disc Clutches and Brakes

Low Inertia Brakes

Specifications

Model Size ATD-	Assembly Number	Drawing Number	Slip Torque Capacity				Duty Factors HP/100 RPM				Max. Bore Rect. Key	
			lb.in.		Nm		A	B	C	D	in.	(mm)
			80 PSI	100 PSI	5.5 BAR	7 BAR						
LIB 104	7-004-100-803-0	-100-901-9	800	1,000	90	113	1.6	1.2	0.6	0.3	1.00	(25)
LIB 204	7-004-200-801-0	B-518	1,600	2,000	90	225	3.2	2.4	1.2	0.6		
LIB 106	7-006-100-203-0	-100-901-9	3,160	3,950	340	435	6.2	4.4	2.2	1.1	2.00	(50)
LIB 206	7-006-200-200-0	D-465	6,320	7,900	680	870	12.5	8.8	4.4	2.2		
LIB 108	7-008-100-108-0	-100-900-9	5,600	7,000	620	790	11.1	8	4	2		
LIB 208	7-008-200-105-0	-200-900-9	11,200	14,000	1,240	1,580	22.2	16	8	4	2.25	(57)
LIB 308	7-008-300-100-0	D-164	16,800	21,000	1,865	2,375	33.3	24	12	6		
LIB 111	7-011-100-107-0	B-105	12,720	15,900	1,400	1,785	25	18	9	5		
LIB 211	7-011-200-102-0	-200-902-9	25,440	31,800	2,800	3,570	50	36	18	10	2.50	(64)
LIB 311	7-011-300-100-0	B-408	38,160	47,700	4,235	5,390	75	54	27	15		
LIB 114	7-014-100-102-0	-100-900-9	22,100	27,625	2,435	3,100	44	31	16	8		
LIB 214	7-014-200-101-0	-200-902-9	44,200	55,250	4,870	6,200	88	62	32	16	3.50	(89)
LIB 314	7-014-300-102-0	B-288	66,300	82,875	7,355	9,365	132	93	48	24		
LIB 116	7-016-100-100-0	D-461	30,270	37,838	3,360	4,275	60	46	24	12		
LIB 216	7-016-200-100-0	-200-904-9	60,541	75,676	6,720	8,550	120	92	48	24	4.00	(102)
LIB 316	7-016-300-100-0	-300-900-9	90,811	113,514	10,080	12,825	180	139	72	36		
LIB 118	7-018-100-100-0	-100-901-9	51,600	64,500	5,705	7,260	102	75	35	21		
LIB 218	7-018-200-100-0	-200-900-9	103,200	129,000	11,410	14,520	204	150	70	42	4.75	(121)
LIB 318	7-018-300-103-0	D-1218	154,840	193,550	17,115	21,780	306	225	105	63		
LIB 121	7-021-100-100-0	D-373	69,887	87,359	7,755	9,870	139	107	55	28		
LIB 221	7-021-200-100-0	D-267	139,775	174,719	15,510	19,740	277	213	111	55	6.00	(152)
LIB 321	7-021-300-100-0	D-740	209,662	262,078	23,265	29,610	416	320	166	83		
LIB 124H	7-025-100-101-0	D-779	122,960	153,700	13,575	17,275	243	180	90	40		
LIB 224H	7-025-200-101-0	D-371	245,920	307,400	27,150	34,550	487	360	180	80	6.00	(152)
LIB 324H	7-025-300-201-0	-300-900-9	368,880	461,100	40,725	51,825	729	540	270	120		
LIB 127	7-027-100-100-0	D-151	137,509	171,886	15,260	19,420	273	210	109	55		
LIB 227	7-027-200-100-0	D-428	275,018	343,773	30,520	38,840	546	420	218	109	6.50	(165)
LIB 327	6-027-300-100-0	D-689	412,527	515,659	45,780	58,260	819	630	327	164		
LIB 130H	7-031-100-100-0	B-312	261,600	327,000	29,630	37,710	519	380	190	100		
LIB 230H	7-031-200-316-0	B-296	523,200	654,000	59,260	75,420	1,038	760	380	200	7.25	(184)
LIB 330H	7-031-300-304-0	-300-904-9	784,800	981,000	88,890	113,130	1,557	1,140	570	300		
LIB 136	7-036-100-100-0	-100-901-9	406,400	508,000	44,920	57,175	805	600	295	165		
LIB 236	7-036-200-100-0	D-722	812,800	1,016,000	89,840	114,350	1,610	1,200	590	330	9.00	(229)
LIB 336	6-036-300-100-0	-300-900-9	1,219,200	1,524,000	134,760	171,525	2,415	1,800	885	495		
LIB 142	7-042-100-303-0	-100-900-9	580,800	726,000	69,160	81,660	1,150	850	425	235		
LIB 242	7-042-200-311-0	-200-901-9	1,162,240	1,452,800	128,320	163,320	2,300	1,700	850	470	14.00	(355)
LIB 342	6-042-300-302-0	-300-303-9	1,742,400	2,178,000	192,480	244,980	3,450	2,550	1,275	705		
LIB 148	7-048-100-300-0	-100-900-9	1,122,000	1,402,500	118,800	151,200	2,225	1,600	800	455		
LIB 248	7-048-200-300-0	-200-901-9	2,244,000	2,805,000	237,600	302,400	4,450	3,200	1,600	915	18.00	(455)
LIB 348	7-048-300-301-0	-300-900-9	3,366,000	4,207,500	356,400	453,600	6,675	4,800	2,400	1,365		
LIB 260	7-060-200-302-0	-200-901-9	4,760,000	5,950,000	473,000	602,000	9,440	5,950	3,470	1,940		
LIB 360	7-060-300-301-0	-300-901-9	7,140,000	8,925,000	709,000	902,300	14,160	8,925	5,205	2,910	19.00	(480)
LIB 460	6-060-400-300-0	E-236	14,280,000	17,850,000	946,000	1,204,000	18,880	11,900	6,940	3,880		

Maximum Air Pressure is 130 PSI / 9 BAR.

Air Tube Disc Clutches and Brakes

Low Inertia Brakes Specifications

Model Size ATD-	Recom- mended Clearance in.	Balance Speed RPM	Hub & C.P.		Swept Area in. ²	Airtube Volume in. ³ (cm ³)		Total Brake Wt.		Hub & Center Plate Wt.			
			Reg- Speed RPM	High Speed RPM*		New	Worn	lb.	(kg)	lb.	(kg)	WR ² / J=mr ²	
												lb.ft. ²	(kgm ²)
LIB 104	1/32	3,325	5,250	5,250*	17	0.9	3.4	11.0	(7)	1.54	(0.7)	0.021	(0.001)
LIB 204	1/16				34	(14.8)	(56)	14.0	(6)	3.88	(1.8)	0.04	(0.002)
LIB 106	1/16-3/32	2,225	3,800	5,700*	39	1.8	11.9	27.5	(12)	6.40	(2.9)	0.24	(0.010)
LIB 206	3/32-5/32				78	(30)	(195)	40.5	(18)	12.17	(5.5)	0.46	(0.019)
LIB 108	1/16-1/8				56			62	(28)	11	(5.0)	0.54	(0.023)
LIB 208	3/32-5/32	1,675	2,870	4,300*	112	3.4	18.3	70	(32)	19	(8.6)	1.00	(0.042)
LIB 308	1/8-3/16				168	(56)	(300)	87	(39)	28	(12.7)	2.00	(0.084)
LIB 111	1/16-1/8				114			130	(59)	23	(10.4)	2.30	(0.097)
LIB 211	3/32-5/32	1,200	2,090	3,125*	228	5.5	30.5	166	(75)	45	(20.4)	4.50	(0.190)
LIB 311	1/8-3/16				342	(90)	(500)	208	(94)	121	(54.9)	7.00	(0.295)
LIB 114	1/16-1/8				158			184	(83)	46	(20.9)	5.7	(0.240)
LIB 214	3/32-5/32	950	1,640	2,450*	316	7.6	42.7	233	(106)	77	(34.9)	11.0	(0.464)
LIB 314	1/8-3/16				474	(125)	(700)	290	(132)	121	(54.9)	16.7	(0.704)
LIB 116	1/16-1/8				228			254	(115)	59	(26.8)	10.2	(0.430)
LIB 216	3/32-5/32	835	1,430	2,150*	455	9.8	56.1	326	(148)	106	(48.1)	19.6	(0.826)
LIB 316	1/8-3/16				683	(161)	(919)	358	(162)	151	(68.5)	29.6	(1.248)
LIB 118	1/16-1/8				264			311	(141)	73	(33.1)	15.0	(0.632)
LIB 218	3/32-5/32	750	1,270	1,910*	528	15.3	85.4	377	(171)	120	(54.4)	28.8	(1.214)
LIB 318	1/8-3/16				792	(251)	(1,400)	461	(209)	180	(81.6)	43.2	(1.821)
LIB 121	3/32-5/32				362			460	(209)	116	(52.6)	32	(1.35)
LIB 221	1/8-3/16	650	1,090	1,650*	724	18.3	97.6	575	(261)	198	(89.8)	61	(2.57)
LIB 321	5/32-7/32				1,086	(300)	(1,599)	723	(328)	312	(141.5)	122	(5.14)
LIB 124H	3/32-5/32				574			618	(280)	132	(60.0)	56	(2.4)
LIB 224H	1/8-3/16	550	950	1,410*	1,148	29.9	159	840	(381)	260	(117.9)	110	(4.6)
LIB 324H	5/32-7/32				1,722	(490)	(2,606)	1,025	(465)	379	(172.0)	160	(6.8)
LIB 127	3/32-5/32				730			760	(345)	187	(84.8)	98	(4.1)
LIB 227	1/8-3/16	500	850	1,250*	1,460	29.9	159	924	(419)	329	(149.2)	191	(8.1)
LIB 327	5/32-7/32				2,190	(490)	(2,606)	1,112	(504)	555	(251.7)	285	(12.0)
LIB 130H	3/32-5/32				827			972	(441)	298	(135.2)	189	(8.0)
LIB 230H	1/8-3/16	450	765	1,130*	1,654	58.6	311	1,350	(612)	546	(247.7)	370	(15.6)
LIB 330H	5/32-7/32				2,481	(960)	(5,096)	1,751	(794)	810	(367.4)	477	(20.1)
LIB 136	3/32-5/32				1,150			1,388	(630)	461	(209.1)	372	(15.7)
LIB 236	1/8-3/16	375	640	950*	2,300	110	415	1,993	(904)	708	(321.1)	725	(30.6)
LIB 336	5/32-7/32				3,450	(1,803)	(6,801)	2,610	(1,184)	1,134	(514.4)	1,091	(46.0)
LIB 142	5/32-7/32				1,400			1,967	(892)	680	(308)	705	(30)
LIB 242	3/16-1/4	325	545	805*	2,800	128	488	2,732	(1,239)	1,197	(543)	1,385	(58)
LIB 342	7/32-9/32				4,200	(2,098)	(7,997)	3,704	(1,680)	1,324	(601)	1,809	(76)
LIB 148	1/8-1/4				2,010			3,158	(1,432)	1,101	(499)	1,785	(75)
LIB 248	5/32-7/32	275	475	705*	4,020	217	824	4,700	(2,132)	1,942	(881)	3,335	(141)
LIB 348	3/16-5/16				6,030	(3,550)	(13,500)	6,540	(2,966)	2,950	(1,338)	4,925	(208)
LIB 260	3/16-5/16				7,230			9,453	(4,288)	2,567	(1,164)	7,077	(298)
LIB 360	1/4-3/8	225	380	575*	10,845	513	1,788	11,643	(5,281)	3,870	(1,755)	10,615	(448)
LIB 460	5/16-7/16				14,460	(8,407)	(29,300)	14,500	(6,577)	5,700	(2,585)	15,070	(635)

* Consult Factory for Special Assembly Number.

Air Tube Disc Clutches and Brakes

Low Inertia Brakes

Sizes 8-36

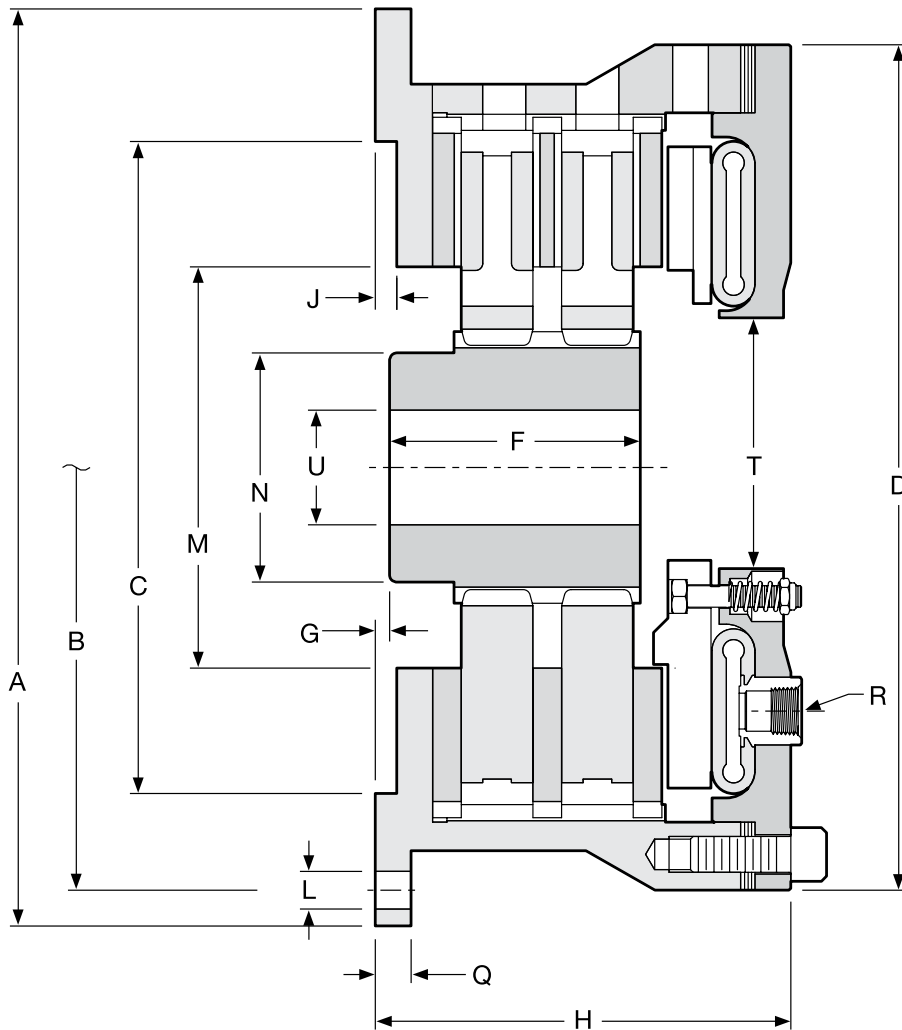

Air Tube Disc Clutches and Brakes

Low Inertia Brakes

Sizes 8-36

Dimensions: inches (mm)

Model Size ATD-	A	B Hole Circle	C Pilot	D	F	G	H
LIB 108	12.13	11.125	8.375 / 8.378	11.13	2.00 (50.8)	.25	4.56 (115.8)
LIB 208	(308.1)	(282.58)	(212.73 / 212.80)	(282.7)	3.25 (82.6)	(6.4)	5.94 (150.9)
LIB 111	16.00	14.750	11.375 / 11.378	14.75	2.75 (69.9)	.13 (3.3)	5.44 (138.2)
LIB 211	(406.4)	(374.65)	(288.93 / 289.00)	(374.7)	4.38 (111.3)	.25 (6.4)	7.19 (182.6)
LIB 114	18.75	17.500	14.375 / 14.378	17.50	3.75 (95.3)	.13 (3.3)	6.06 (153.9)
LIB 214	(476.3)	(444.50)	(365.13 / 365.20)	(444.5)	4.50 (114.3)	.38 (9.7)	8.00 (203.2)
LIB 116	21.25	20.000	16.250 / 16.253	20.00	4.00 (101.6)	0.38	6.31 (160.3)
LIB 216	(539.8)	(508.00)	(412.75 / 412.83)	(508.0)	4.75 (120.7)	(9.7)	8.25 (209.6)
LIB 316					6.63 (168.4)		10.19 (258.8)
LIB 118	23.25	22.000	18.250 / 18.253	22.00	4.00 (101.6)	0.44	6.69 (169.9)
LIB 218	(590.6)	(558.80)	(463.55 / 463.63)	(558.8)	4.75 (120.7)	(11.2)	8.63 (219.2)
LIB 318					6.50 (165.1)		10.63 (270.0)
LIB 121	27.00	25.500	21.375 / 21.378	24.88	4.00 (101.6)	.75	7.38 (187.5)
LIB 221	(685.8)	(647.70)	(542.93 / 543.00)	(632.0)	5.13 (130.3)	(19.1)	9.31 (236.5)
LIB 321					7.13 (181.1)		11.75 (298.5)
LIB 124H	30.00	28.750	24.375 / 24.378	29.00	4.00 (101.6)	.69 (17.5)	7.63 (193.8)
LIB 224H	(762)	(730.25)	(619.13 / 619.20)	(736.6)	5.13 (130.3)	.75 (19.1)	9.94 (252.5)
LIB 324H					7.50 (190.5)	.75 (19.1)	12.25 (311.2)
LIB 127	32.75	31.500	27.375 / 27.378	31.00	4.50 (114.3)	0.75 (19.1)	7.88 (200.2)
LIB 227	(831.9)	(800.10)	(695.33 / 695.40)	(787.4)	6.88 (174.8)	—	10.38 (263.7)
LIB 327					—	—	—
LIB 130H	37.00	35.500	30.375 / 30.378	34.75	5.00 (127.0)	.63 (16.0)	8.38 (212.9)
LIB 230H	(939.8)	(901.70)	(771.53 / 771.60)	(882.7)	7.13 (181.1)	1.88 (47.8)	11.81 (300.0)
LIB 330H					11.88 (301.8)	.63 (16.0)	15.31 (388.9)
LIB 136	43.50	42.000	36.375 / 36.378	41.00	5.63 (143.0)	0.63	9.50 (241.3)
LIB 236	(1,104.9)	(1,066.80)	(923.93 / 924.00)	(1,041.4)	9.00 (228.6)	(16.0)	12.88 (327.2)

Dimensions: inches (mm)

Model Size ATD-	L			R			U				
	J	No. -	Size	M	N	Q	No.-	Size	T	Min.	Max.
LIB 108	0.25	6 -	17/32 (13.5)	5.38	3.50	0.50	2 -	1/2 NPT	2.25	1.00	2.00
LIB 208	(6.4)			(136.7)	(88.9)	(12.7)				(25)	(50.8)
LIB 111	0.38	6 -	21/32 (16.7)	7.00	4.00	0.63	2 -	1/2 NPT	3.25	1.00	2.50
LIB 211	(9.7)			(177.8)	(101.6)	(16.0)				(25)	(63.5)
LIB 114	0.38	8 -	21/32 (16.7)	9.44	5.50	0.63	2 -	1/2 NPT	5.06	1.38	3.50
LIB 214	(9.7)			(239.8)	(139.7)	(16.0)				(35.1)	(88.9)
LIB 116	0.38	12 -	21/32 (16.7)	10.50	6.00	0.63	2 -	1/2 NPT	6.13	1.38	4.00
LIB 216	(9.7)			(266.7)	(152.4)	(16.0)				(35.1)	(101.6)
LIB 316											
LIB 118	0.38	12 -	21/32 (16.7)	12.50	7.00	0.63	3 -	1/2 NPT	7.75	2.00	4.75
LIB 218	(9.7)			(317.5)	(177.8)	(16.0)				(50.8)	(120.7)
LIB 318											
LIB 121	0.31	12 -	21/32 (16.7)	14.50	9.00	.75	3 -	1/2 NPT	9.25	2.00	6.00
LIB 221	(7.9)			(368.3)	(228.6)	(19.1)				(50.8)	(152.4)
LIB 321											
LIB 124H	0.25	12 -	21/32 (16.7)	14.50	9.00	.75	3 -	1/2 NPT	13.25	2.00	6.00
LIB 224H	(6.4)			(368.3)	(228.6)	(19.1)				(50.8)	(152.4)
LIB 324H											
LIB 127	0.25	16 -	21/32 (16.7)	16.25	9.00	.75	3 -	1/2 NPT	13.25	2.50	6.50
LIB 227	(6.4)			(412.8)	(228.6)	(19.1)				(63.5)	(165.1)
LIB 327	—										
LIB 130H	0.25	18 -	25/32 (19.8)	19.25	10.00	.75	4 -	1/2 NPT	15.00	2.50	7.25
LIB 230H	(6.4)			(489)	(254)	(19.1)				(63.5)	(184.2)
LIB 330H											
LIB 136	0.25	18 -	13/16 (20.6)	23.63	12.00	.88	4 -	1/2 NPT	22.75	6.00	9.00
LIB 236	(6.4)			(600.2)	(304.8)	(22.4)				(152.4)	(228.6)

Note: For mounting, use socket head capscrews conforming to the ASTM-574-97a.
(Consult factory for drawing before final layout.)

Air Tube Disc Clutches and Brakes

Low Inertia Brakes

Sizes 6, 42-60

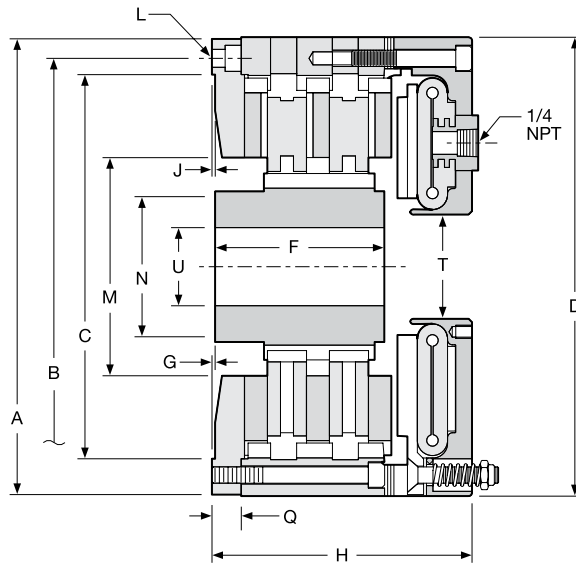

Size 6

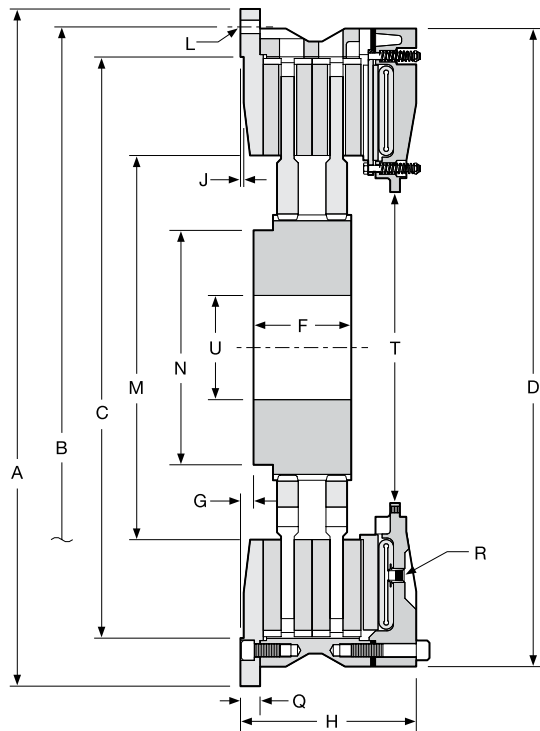

Sizes 42-60

Air Tube Disc Clutches and Brakes

Low Inertia Brakes

Sizes 6, 42-60

Dimensions: inches (mm)

Model Size ATD-	A	B Hole Circle	C Pilot	D	F	G	H
LIB 106	8.75	8.000	7.377 / 7.379	8.81	2.00 (50.8)	0.00 (0.0)	3.75 (95.3)
LIB 206	(222.3)	(203.20)	(187.38 / 187.43)	(223.8)	3.25 (82.6)	0.06 (1.5)	5.00 (127.0)
LIB 142	52.00	49.250	44.625 / 44.628	49.00	5.63 (143.0)	1.00 (25.40)	9.75 (247.7)
LIB 242	(1,320.8)	(1,250.95)	(1,133.48 / 1,133.55)	(1,244.6)	7.50 (190.5)		13.5 (342.9)
LIB 148	61.00	58.000	52.000 / 52.005	56.75	6.00 (152.4)	0.00 (0.0)	10.69 (271.5)
LIB 248	(1,549.4)	(1,473.20)	(1,320.80 / 1,320.93)	(1,441.5)	8.75 (222.3)	1.00 (25.4)	15.06 (382.5)
LIB 260	70.50	74.500	60.000 / 59.990	70.50	9.38 (238.3)	3.50 (88.9)	21.25 (539.8)
LIB 360	(1,790.7)	(1,892.30)	(1,524.0 / 1,523.7)	(1,790.7)	12.25 (311.2)		22.88 (581.2)

Dimensions: inches (mm)

Model Size ATD-	J	L		M	N	Q	R		T	U	
		No.-	Size				No. -	Size		Min.	Max.
LIB 106	0.06	4 -	0.34 (8.6)	4.19	2.69 (68.3)	0.56	2 -	1/4 NPT	2.00	0.60	2.00
LIB 206	(1.5)			(106.4)		(14.2)			(50.8)	(15.2)	(50.8)
LIB 142	0.25	24 -	1.06 (26.9)	29.50	18.00 (457.2)	1.50	4 -	1/2 NPT	23.88	8.00	14.00
LIB 242	(6.4)			(749.3)		(38.1)			(606.6)	(203.2)	(355.6)
LIB 148	0.25	24 -	1.06 (26.9)	32.00	25.75 (654.1)	1.50	4 -	1/2 NPT	25.25	10.00	18.00
LIB 248	(6.4)			(812.8)		(38.1)			(641.4)	(254.0)	(457.2)
LIB 260	0.38	24 -	2.06 (52.3)	35.50	27.00 (685.8)	3.25	6 -	1/2 NPT	28.5	11.00	19.00
LIB 360	(9.5)			(901.7)		(797.6)			(723.9)	(279.4)	(482.6)

Note: For mounting, use socket head capscrews conforming to the ASTM-574-97a.
(Consult factory for drawing before final layout.)

B

Air Tube Disc Clutches and Brakes

Brake Air Hose Kits

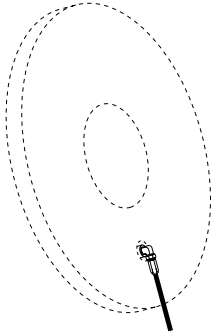

Model	Part Number
8"	8-908-912-100-5 8-908-924-100-5 QRV

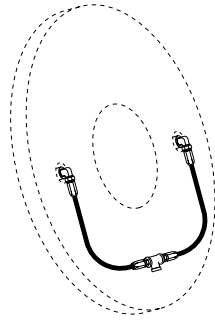

Model	Part Number
6"	8-906-912-200-4 8-906-931-201-5 QRV

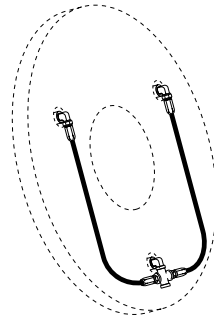

Model	Part Number
18"	8-918-912-200-5 8-918-931-200-5 QRV

8"	8-908-913-200-5 8-908-931-200-5 QRV
----	--

21"	8-921-913-200-5 8-921-931-200-5 QRV
-----	--

11"	8-911-913-200-5 8-911-931-200-5 QRV
-----	--

24"	8-924-913-200-5 8-924-931-200-5 QRV
-----	--

14"	8-914-913-200-5 8-914-921-200-5 QRV
-----	--

27"	8-927-913-200-5 8-927-921-200-5 QRV
-----	--

16"	8-916-913-200-5 8-916-921-200-5 QRV
-----	--

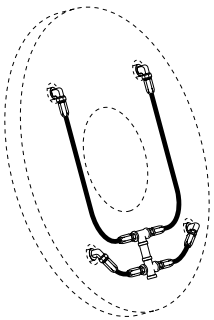

Model	Part Number
30"	8-930-913-400-5 8-930-931-400-5 QRV

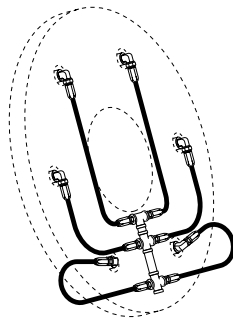

Model	Part Number
60"	8-960-912-500-5 8-960-923-400-6 QRV

36"	8-936-913-400-6 8-936-931-400-6 QRV
-----	--

42"	8-942-913-400-6 8-924-931-400-6 QRV
-----	--

48"	8-948-912-400-6 8-948-923-400-6 QRV
-----	--

Air hose kits contain all necessary parts (fittings, hoses and extensions) to completely plumb the brake air system.

Optional Quick Release Valves can replace elbows on most units (see page 35).

Roto-couplings (see page 35).

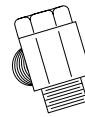

Air Tube Disc Clutches and Brakes

Low Inertia Clutches and Brakes

Component Parts

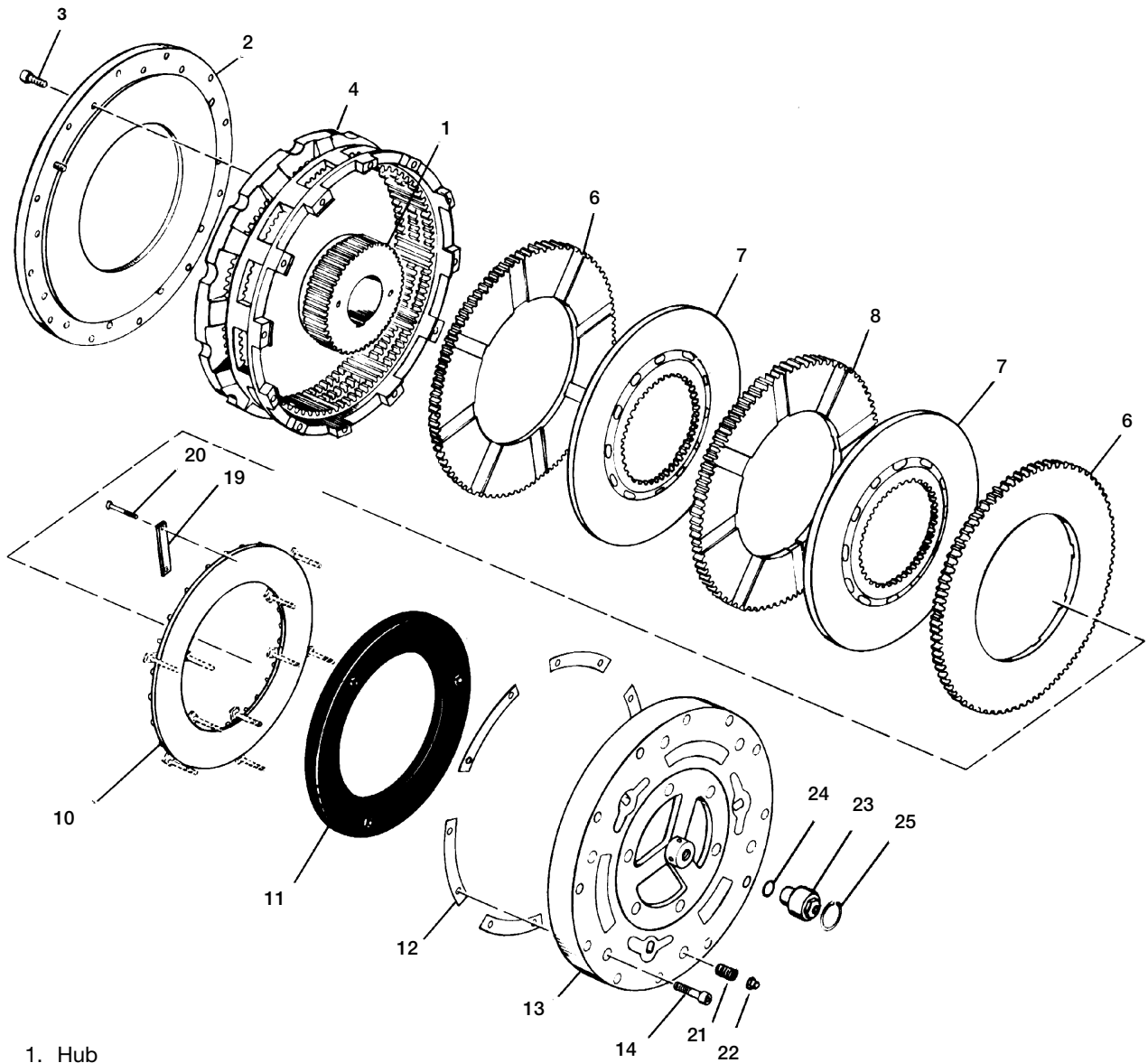

- | | | |
|---|---------------------------|---------------------|
| 1. Hub | 10. Pressure Plate | 21. Release Springs |
| 2. Demountable Back Plate | 11. Airtube | 22. Flexloc Nuts |
| 3. Socket Head Capscrews | 12. Shims | 23. Roto-coupling |
| 4. Ring | 13. Airtube Holding Plate | 24. "O" Ring |
| 6. Grooved Friction Disc
(grooved on one side) | 14. Socket Head Capscrews | 25. Snap Ring |
| 7. Center Plate | 19. Pressure Plate Lugs | |
| 8. Grooved Friction Disc
(grooved on both sides) | 20. Hex Head Capscrews | |



Air Tube Disc Clutches and Brakes

High Torque Clutches

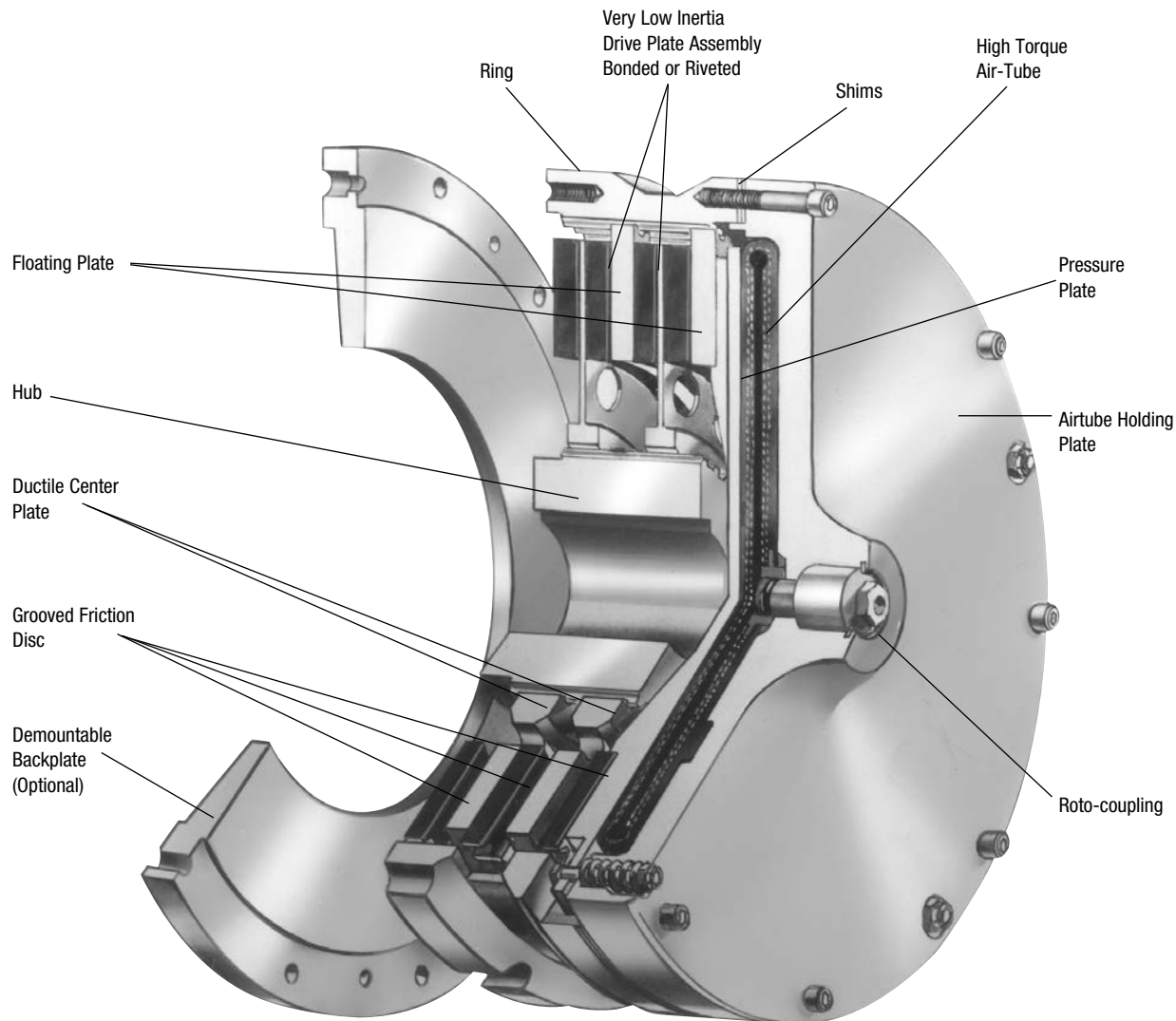

Wichita High Torque Clutches provide the highest torque to size ratios of any Wichita Clutch. They provide smooth controlled starts and stops and are designed for minimum power loss due to low rotating inertia.

- Extremely fast response
- No lubrication
- High torque to size ratio
- Low rotating inertia

Selection Requirements

To properly select a High Torque Clutch and Low Inertia Brake, the following information must be determined.

1. Torque necessary to do the work (clutch)
2. Rotating inertia to be stopped and started
3. Heat generated by each stop/start
4. Torque necessary to stop inertia (brake)
5. Shaft size

Air Tube Disc Clutches and Brakes

Selection Example

Data

Rated Tonnage As Required
 Crankshaft Speed 30 RPM
 (Continuous Run)
 Clutch-Brake Shaft RPM 204 RPM
 Crankshaft Speed 30 RPM
 Degrees of Crank to start 90°
 Degrees of Crank to stop 90°
 Connecting Rod Length = b 36 in.
 Stroke 6 in.
 1/2 of Press Stroke (throw) = a 3 in.
 WR² of Parts on Backshaft 78.2 lb.ft.²
 WR² of Parts on Crankshaft 39,091 lb.ft.²
 Material Shear Stress 45,000 PSI
 Blade Width 60 in.
 Shaft Size 4 in.
 Maximum Material to be Sheared x
 Air Pressure Available 100 PSI

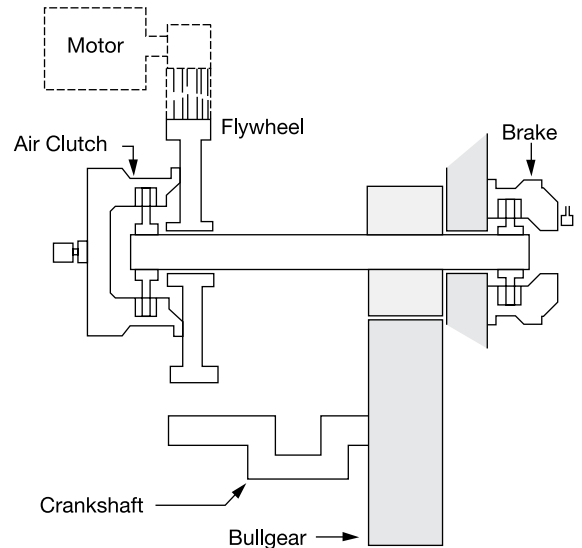

B

Calculations

Torque @ Crank
 = (Material Shear Stress) (x) (Blade Width) (Torque Arm)

Torque arm = y = (x) (tan α)

c = a + b - x
 = 3 + 36 - .25
 = 38.75 in.

Cos α

$$= \frac{b^2 + c^2 - a^2}{2bc}$$

$$= \frac{(36)^2 + (38.75)^2 - (3)^2}{(2)(36)(38.75)}$$

$$= .99948$$

α = 1.8478°

Torque Arm = y = (c) (tan α)

$$= (38.75) (\tan 1.8478^\circ)$$

$$= (38.75) (.03226)$$

$$= 1.25 \text{ in.}$$

Torque @ Crank

$$= (\text{Material Shear Stress}) (x) (\text{Blade Width}) (\text{Torque Arm})$$

$$= (45,000) (.25) (60) (1.25)$$

$$= 843,750 \text{ lb.in.}$$

Torque @ Clutch

$$= (\text{Torque @ Crank}) \div \frac{\text{Clutch RPM}}{\text{Crankshaft RPM}}$$

$$= 843,750 \div \frac{204 \text{ RPM}}{30 \text{ RPM}}$$

$$= 124,081 \text{ lb.in.}$$

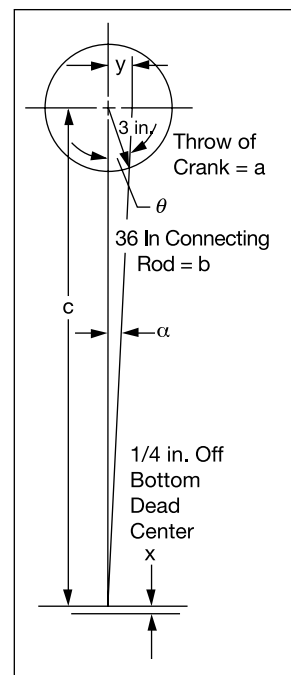

Air Tube Disc Clutches and Brakes

High Torque Clutches

Clutch Selection

Per the application factors on page 23 a "Back Geared Press is 'Group C'."

$$\frac{\text{HP}}{100 \text{ RPM}} = \frac{\text{Torque}}{630} = \frac{124,081}{630} = 197$$

The preliminary clutch selection based on 124,081 lb.in. and 197 HP/100 RPM is an ATD-224 Low Inertia High Torque Clutch. (page 48)

A Low Inertia High Torque Clutch was chosen because of the continuous duty (non-cyclic) operation having a relatively low heat HP requirement.

ATD-224 Low Inertia High Torque Clutch = 280 HP/100 RPM

Rated Torque = 480,000 lb.in @ 100 PSI

Required clutch air pressure is:

$$\text{PSI} = \frac{\text{Clutch required torque} \times (100 \text{ PSI})}{\text{Catalog rated torque @ 100 PSI}}$$

Actual required clutch PSI

$$\text{PSI} = \frac{124,081}{480,000} \times (100 \text{ PSI})$$

= 26 PSI minimum is required.

This application has 100 PSI available.

Contact velocity of rotating disc is:

$$V_c = \frac{(\text{Diameter of Center Plate}) (\pi) (\text{RPM})}{12 \text{ in.ft.}}$$

$$= \frac{24}{12} (\pi) (204) = 1,282 \frac{\text{ft.}}{\text{min.}}$$

(Ductile iron is not required, see page 23).

Maximum bore for ATD-224 High Torque Low Inertia Clutch = 7 in.

Check clutch inflation time for 90° start angle (see page 52, PSI pressure curves)

Estimated time to start

$$= \frac{\text{Start Angle}}{360^\circ} \frac{60}{\text{Crankshaft RPM}}$$

$$= \frac{90^\circ}{360^\circ} \frac{60}{30} = 0.5 \text{ sec.}$$

P_1 = Line pressure to clutch

P_2 = Required pressure to clutch

LN = Natural log

k = Inflation coefficient
(ATD-224 H.T. @ 100 PSI)

= 2,600

u = For ATD-224 H.T. Clutch @ 100 PSI

= 2.5

Time to 26% of line pressure.

$$t = \frac{\text{LN} \left[\frac{P_1}{P_1 - P_2} \right]^{\frac{1}{u}}}{k}$$

$$t = \left[\frac{\text{LN} \left[\frac{100}{100 - 26} \right]}{2,600} \right]^{\frac{1}{2.5}}$$

= 0.027 seconds

Clutch will be fully inflated at 90° of crankshaft rotation.

Clutch exhaust time @ 100 PSI = E = .078 (page 52).

Note:

This application example is for preliminary sizing only. Contact a Wichita Sales Engineer or the factory for final selection.

Low Inertia Brake Selection

To properly size a brake, the total rotating inertia reflected to the clutch and brake shaft must be known.

Alternate shaft WR²
referred to clutch shaft

$$= \frac{\text{Alternate shaft WR}^2}{\text{shaft WR}^2} \left[\frac{\text{Alternate shaft RPM}}{\text{clutch shaft RPM}} \right]^2$$

$$= 39,091 \left[\frac{30}{204} \right]^2$$

WR² referred to
clutch-brake shaft = 845.4 lb.ft.²
@204 RPM

Total inertia
Back shaft WR² = 78.2 lb.ft.²

Clutch hub &
drive plate WR² from
Specification Table = 101.0 lb.ft.²

Estimate brake WR²
(assume same as clutch) = 101.0 lb.ft.²

Total WR² referred
to clutch-brake = 1,125.66 lb.ft.²
(Estimated)

Estimated time to stop:

$$= \left[\frac{\text{Start Angle}}{360^\circ} \right] \left[\frac{60}{\text{Crankshaft RPM}} \right]$$

$$= \left[\frac{90^\circ}{360^\circ} \right] \left[\frac{60}{30} \right] = .5 \text{ sec.}$$

The deceleration torque is:

$$T = 12 \left[\frac{\text{WR}^2}{32.2} \right] \left[\frac{\text{Brake RPM}}{9.5(t)} \right]$$

$$= 12 \left[\frac{1125.6}{32.2} \right] \left[\frac{204}{9.5 (.5)} \right]$$

Deceleration Torque = 18,015 lb.in.

The HP / 100 RPM for this application is:

$$\frac{\text{HP}}{100 \text{ RPM}} = \frac{\text{Torque (lb.in.)}}{630} = \frac{18,015}{630} = 29 \text{ HP/100 RPM}$$

Consult the Specification Table on pages 36-37 to select a brake based on torque and HP/100 RPM. Under "Duty C", an ATD-214 brake has 32 HP/100 capacity and 55,250 lb.in. torque. The rotating inertia of an ATD-214 Low Inertia Brake is 11 lb.ft.². Therefore, the actual rotating inertia reflected to brake is 1035.6 lb.ft.².

$$\text{The actual deceleration torque} = 12 \left[\frac{1035.6}{32.2} \right] \left[\frac{204}{9.5} \right]$$

$$= 16,575 \text{ lb. in.}$$

Required air pressure is:

$$\text{Brake} = \frac{\text{Brake required torque} \times (100 \text{ PSI})}{\text{Catalog rated torque @ 100 PSI}}$$

$$= \frac{16,575 \text{ lb. in.}}{55,250 \text{ lb. in.}} \times 100$$

$$= 30 \text{ PSI minimum}$$

This application has 100 PSI available.

The average heat HP each stop

$$= \frac{(\text{Brake Torque})}{63,000} \times \text{RPM} \times 1/2$$

$$= \frac{16,575}{63,000} \times 204 \times .5$$

$$= 26.8 \text{ HP}$$

$$\text{Friction area necessary to absorb heat} = \frac{\text{Heat HP}}{.7} = \frac{26.8}{.7} = 39 \text{ in.}^2$$

$$\frac{\text{heat HP}}{\text{Absorbion rate for .5 sec.}} \text{ (see page 174)}$$

An ATD-214 Low Inertia Brake has 316 in.² of friction lining available to absorb heat generated by stopping. Maximum bore for an ATD-214 Low Inertia Brake is 4-1/8 inches.

Based on the given application data and the following calculations, an ATD-224 Low Inertia High Torque Clutch and ATD-214 Low Inertia Brake have been selected as having sufficient torque and heat dissipation capacity with minimum diameter and sufficient bore capacity.

Note:

These application examples are for preliminary sizing only. Contact a Wichita Sales Engineer or the factory for final selection.

Air Tube Disc Clutches and Brakes

High Torque Clutches

Specifications

Model Size	Assembly Number	Slip Torque Capacity				Duty Factors				Max. Bore	
		lb.in.		Nm		HP/100 RPM				in.	(mm)
ATD-		80 PSI	100 PSI	5.5 BAR	7 BAR	A	B	C	D		
HTC 104	6-004-100-400-0	800	1,000	90	113	1.6	1.2	0.6	0.3	1.00	(25)
HTC 204	6-004-200-802-0	1,600	2,000	180	226	3.2	2.4	1.2	0.6		
HTC 106	6-006-100-400-0	4,000	5,000	475	602	8	5.7	2.8	1.4	2.00	(50)
HTC 206	6-006-200-400-0	8,000	10,000	950	1,204	16	11.4	5.7	2.8		
HTC 108	6-008-100-407-0	8,800	11,000	977	1,243	17	13	6	3		
HTC 208	6-008-200-417-0	17,600	22,000	1,953	2,486	34	25	13	6	2.38	(60)
HTC 308	6-008-300-400-0	26,400	33,000	2,930	3,729	51	38	19	9		
HTC 111	6-011-100-408-0	20,000	25,000	2,220	2,825	38	28	14	7		
HTC 211	6-011-200-422-0	40,000	50,000	4,440	5,650	76	56	28	14	2.63	(67)
HTC 311	6-011-300-406-0	60,000	75,000	6,660	8,475	114	84	42	21		
HTC 114	6-014-100-405-0	38,400	48,000	4,261	5,423	75	55	27	14	4.13	(105)
HTC 214	6-014-200-403-0	76,800	96,000	8,522	10,846	160	114	55	28	3.63	(92)
HTC 314	6-014-300-411-0	115,200	144,000	12,783	16,269	225	165	81	42	4.63	(118)
HTC 116	6-016-100-403-0	59,480	74,350	6,600	8,400	118	91	47	24		
HTC 216	6-016-200-402-0	118,960	148,700	13,200	16,800	236	182	94	47	4.00	(102)
HTC 316	6-016-300-401-0	178,440	223,050	19,800	25,200	354	272	142	71		
HTC 118	6-018-100-400-0	84,000	105,000	9,321	11,863	165	120	60	30		
HTC 218	6-018-200-400-0	168,000	210,000	18,642	23,726	330	240	120	60	4.75	(120)
HTC 318	6-018-300-400-0	252,000	315,000	27,963	35,589	495	360	180	90		
HTC 121	6-021-100-400-0	136,000	170,000	15,091	19,207	270	208	108	54		
HTC 221	6-021-200-401-0	272,000	340,000	30,182	38,414	540	415	216	108	6.00	(152)
HTC 321	6-021-300-400-0	408,000	510,000	45,273	57,621	810	623	324	162		
HTC 124	6-024-100-401-0	192,000	240,000	21,305	27,116	385	280	140	70		
HTC 224	6-024-200-405-0	384,000	480,000	42,610	54,232	770	560	280	140	6.00	(152)
HTC 324	6-024-300-401-0	576,000	720,000	63,915	81,348	1,155	840	420	210		
HTC 424	6-024-400-400-0	768,000	960,000	85,220	108,464	1,540	1,120	560	280		
HTC 127	6-027-100-404-0	289,680	362,100	32,144	40,911	575	442	230	115	6.50	(165)
HTC 227	6-027-200-411-0	579,360	724,200	64,288	81,821	1,150	884	460	230		
HTC 327	6-027-300-402-0	869,040	1,086,300	96,432	122,732	1,724	1,326	690	345	6.00	(152)
HTC 130	6-030-100-400-0	376,000	470,000	41,722	53,101	750	535	270	135	7.25	(184)
HTC 230	6-030-200-408-0	752,000	940,000	83,445	106,203	1,500	1,070	540	270		
HTC 330	6-030-300-415-0	1,128,000	1,410,000	125,167	159,304	2,250	1,605	810	405	8.00	(203)
HTC 136	6-036-100-400-0	752,000	940,000	84,445	106,200	1,555	1,120	560	280	8.00	(203)
HTC 236	6-036-200-409-0	1,504,000	1,880,000	166,890	212,400	3,100	2,240	1,120	560		
HTC 336	6-036-300-404-0	2,256,000	2,820,000	250,335	318,600	4,665	3,360	1,680	840	9.25	(235)
HTC 148	6-048-100-400-0	1,888,000	2,360,000	209,500	266,637	3,745	2,690	1,345	670		
HTC 248	6-048-200-406-0	3,776,000	4,720,000	419,000	533,273	7,490	5,380	2,690	1,345	18.00	(455)
HTC 348	6-048-300-403-0	5,664,000	7,080,000	628,500	799,910	11,235	8,070	4,035	2,010		

Maximum Air Pressure is 100 PSI / 7 BAR.

Air Tube Disc Clutches and Brakes

High Torque Clutches Specifications

Model Size ATD-	Recom- mended Clearance in.	Balance Speed RPM	Max. Speed		Swept Area in. ²	Airtube Volume in. ³ (cm ³)		Total Clutch				Hub & Center Plate			
			Reg- Speed RPM	High Speed RPM*		New	Worn	Wt.		WR ² / J=mr ²		Wt.		WR ² / J=mr ²	
								lb.	(kg)	lb.ft. ²	(kgm ²)	lb.	(kg)	lb.ft. ²	(kgm ²)
HTC 104	1/32-1/16				17	1.3	5	11.0	(5)	0.4	(0.018)	1.50	(0.7)	0.021	(0.001)
HTC 204	1/32-1/16	NA	2,100	2,600*	34	(21.3)	(82)	14.0	(6)	0.6	(0.023)	3.88	(1.8)	0.04	(0.002)
HTC 106	1/16-3/32				39	3	14	22.5	(10)	1.4	(0.059)	6.40	(2.9)	0.24	(0.010)
HTC 206	3/32-5/32	NA	2,100	2,600*	78	(49)	(229)	44.2	(20)	3.1	(0.131)	12.60	(5.7)	0.50	(0.021)
HTC 108	1/16-1/8				56	5	30	109.4	(50)	21.43	(0.903)	15	(6.8)	1.35	(0.057)
HTC 208	3/32-5/32	1,675	1,890	2,500*	112	(82)	(492)	148.4	(67)	28.72	(1.211)	30	(13.6)	2.60	(0.110)
HTC 308	1/8-3/16				168			140	(64)	30	(1.265)	40.5	(18.4)	4.00	(0.169)
HTC 111	1/16-1/8				114	8	48	133	(60)	27	(1.14)	23	(10.4)	2.30	(0.097)
HTC 211	3/32-5/32	1,200	1,430	2,200*	228	(131)	(787)	170	(77)	34	(1.43)	45	(20.4)	4.50	(0.190)
HTC 311	1/8-3/16				342			208	(94)	52	(2.19)	121	(54.9)	7.00	(0.295)
HTC 114	1/16-1/8				158	12	75	120	(54)	31	(1.31)	48	(21.8)	5.6	(0.236)
HTC 214	3/32-5/32	950	1,225	1,930*	316	(197)	(1,229)	265	(120)	70	(2.95)	78	(35.4)	11.2	(0.472)
HTC 314	1/8-3/16				474			279	(127)	72	(3.04)	31	(14.1)	15.1	(0.637)
HTC 116	1/16-1/8				228	10	56	236	(107)	84	(3.54)	50	(22.7)	8.2	(0.346)
HTC 216	3/32-5/32	835	1,080	1,700*	455	(164)	(918)	295	(134)	105	(4.43)	107	(48.5)	19.6	(0.826)
HTC 316	1/8-3/16				683			357	(162)	120	(5.06)	151	(68.5)	28.6	(1.206)
HTC 118 (0.658)	1/16-1/8				264	18	101	375	(170)	182	(7.67)	80	(36.3)	15.6	
HTC 218	3/32-5/32	750	985	1,530*	528	(295)	(1,655)	485	(220)	200	(8.43)	118	(53.5)	28.8	(1.214)
HTC 318	1/8-3/16				792			530	(240)	250	(10.54)	180	(81.6)	45.0	(1.897)
HTC 121	3/32-5/32				362	38	201	557	(253)	334	(14.08)	101	(45.8)	31	(1.31)
HTC 221	1/8-3/16	650	850	1,400*	724	(623)	(3,294)	697	(316)	427	(18.00)	198	(89.8)	61	(2.57)
HTC 321	5/32-7/32				1,086			757	(343)	400	(16.86)	290	(131.5)	122	(5.14)
HTC 124	3/32-5/32				574			702	(318)	498	(20.99)	134	(60.8)	56	(2.4)
HTC 224	1/8-3/16	550	765	1,210*	1,148	50	250	920	(417)	635	(26.77)	260	(117.9)	110	(4.6)
HTC 324	5/32-7/32				1,722	(819)	(4,097)	1,190	(540)	856	(36.09)	386	(175.1)	163	(6.9)
HTC 424	3/16-1/4				2,296			1,291	(586)	917	(38.66)	466	(211.4)	209	(8.8)
HTC 127	3/32-5/32				730	61	323	989	(449)	785	(33.1)	168	(76.2)	98	(4.1)
HTC 227	1/8-3/16	500	700	1,090*	1,460	(1,000)	(5,293)	1,192	(541)	968	(40.8)	304	(137.9)	191	(8.1)
HTC 327	5/32-7/32				2,190			1,413	(641)	1,183	(49.9)	455	(206.4)	283	(11.9)
HTC 130	3/32-5/32				827	80	395	1,525	(692)	1,836	(77.4)	272	(123.4)	186	(7.8)
HTC 230	1/8-3/16	450	620	1,000*	1,654	(1,311)	(6,473)	1,925	(873)	2,425	(102.2)	529	(240.0)	369	(15.6)
HTC 330	5/32-7/32				2,481			2,240	(1,016)	2,720	(114.7)	800	(362.9)	495	(20.9)
HTC 136	3/32-5/32				1,150			2,190	(993)	3,650	(153.9)	376	(170.6)	368	(15.5)
HTC 236	1/8-3/16	375	525	800*	2,300	120	770	2,800	(1,270)	4,390	(185.1)	750	(340.2)	755	(31.8)
HTC 336	5/32-7/32				3,450	(1966)	(12618)	3,221	(1,461)	4,866	(205.1)	1,206	(547.0)	1,140	(48.1)
HTC 148	1/8-1/4				2,010			7,326	(3,323)	25,703	(1,084)	1,711	(776)	1,828	(77)
HTC 248	7/32-9/32	275	380	580*	4,020	(3,277)	(23,434)	8,497	(3,854)	28,356	(1,195)	1,994	(904)	3,411	(144)
HTC 348	3/16-5/16				6,030			9,768	(4,431)	32,008	(1,349)	2,708	(1,228)	4,899	(207)

* Consult Factory for Special Assembly Number.

B

Air Tube Disc Clutches and Brakes

High Torque Clutches

Component Parts

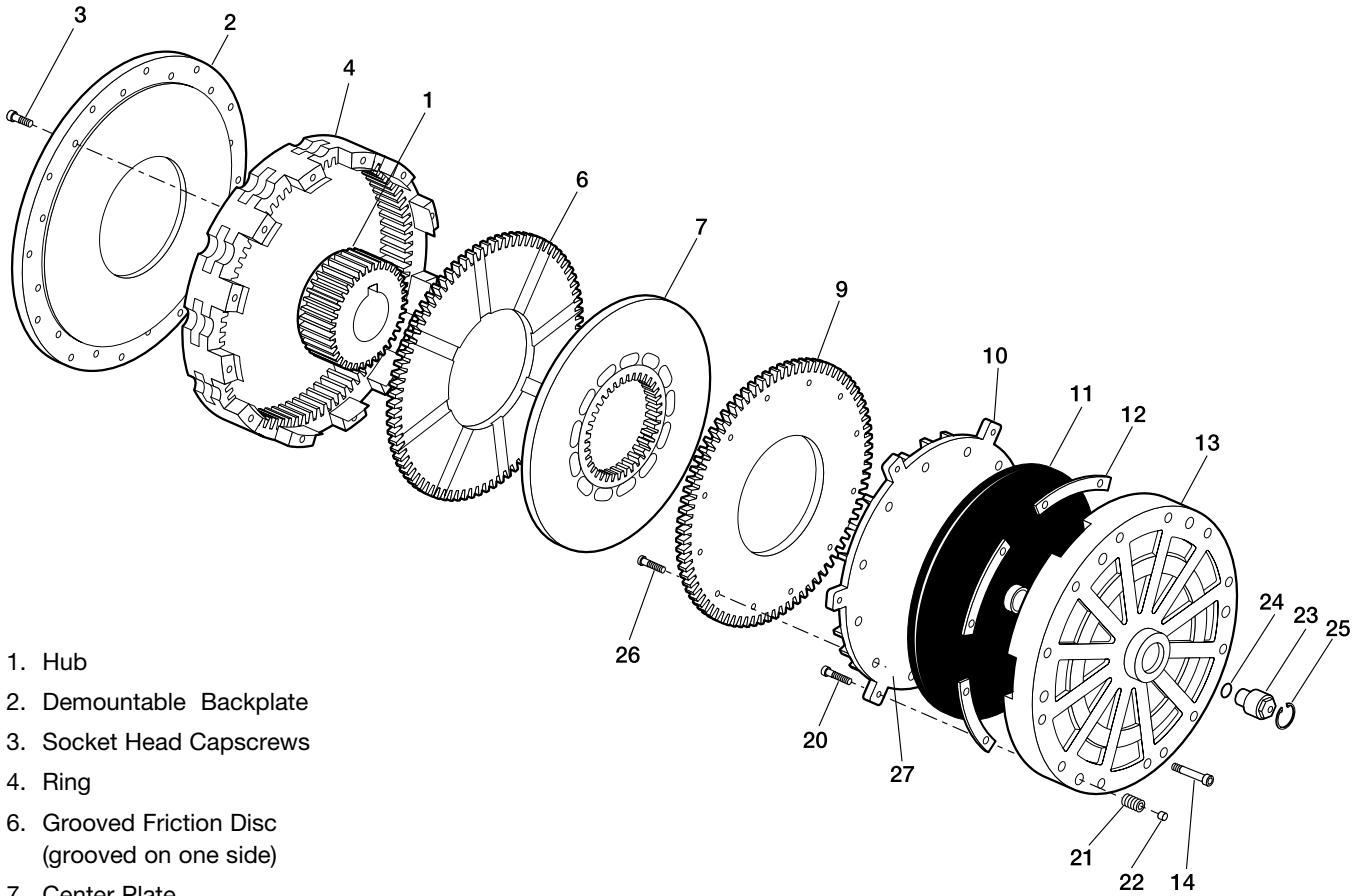

- | | |
|---|------------------------------|
| 1. Hub | 21. Release Springs |
| 2. Demountable Backplate | 22. Flexloc Nut |
| 3. Socket Head Capscrews | 23. Internal Roto-Coupling |
| 4. Ring | 24. "O" Ring |
| 6. Grooved Friction Disc
(grooved on one side) | 25. Snap Ring |
| 7. Center Plate | 26. Flathead Socket Capscrew |
| 9. Grooved Friction Disc | 27. Slotted Flush Nut |
| 10. Pressure Plate | |
| 11. Pancake Air Tube | |
| 12. Shims | |
| 13. Air Tube Holding Plate | |
| 14. Socket Head Capscrews | |
| 20. Hex Head Capscrew | |



Air Tube Disc Clutches and Brakes

High Torque Clutches

Inflation Coefficients

Model Size ATD-	Inflation Coefficients Operating Air Pressure					
	50 PSI		75 PSI		100 PSI	
	K	U	K	U	K	U
111	393,000	3	151,000	3	5,100	4
211	393,000	3	151,000	3	5,100	4
114	49,000	3	30,000	3	17,600	3
214	49,000	3	30,000	3	17,600	3
118	5,700	2.8	5,700	2.8	7,500	3
218	5,700	2.8	5,700	2.8	7,500	3
124	10,400	3	5,200	2.7	2,600	2.5
224	10,400	3	5,200	2.7	2,600	2.5
130	940	2.2	1,070	2.2	590	2
230	940	2.2	1,070	2.2	590	2
136	77,000	3.5	58,000	3.5	44,000	3.5
236	77,000	3.5	58,000	3.5	44,000	3.5
148	1,200	2.5	1,240	3.5	800	2.5
248	1,200	2.5	1,240	3.5	800	2.5

B

Exhaust Coefficients

Model Size ATD-	Exhaust Coefficients Operating Air Pressure								
	50 PSI			75 PSI			100 PSI		
	R	E	V	R	E	V	R	E	V
111	480,000	.04	4	180,000	.05	4	*	.056	5
211	480,000	.04	4	180,000	.05	4	*	.056	5
114	5,600	.032	2.5	2,200	.044	2.5	910	.064	2.5
214	5,600	.032	2.5	2,200	.044	2.5	910	.064	2.5
118	4,100	.062	3	9,800	.1	4	8,500	.104	4
218	4,100	.062	3	9,800	.1	4	8,500	.104	4
124	280	.06	2	775	.068	2.5	575	.078	2.5
224	280	.06	2	775	.068	2.5	575	.078	2.5
130	690	.072	2.5	500	.083	2.5	500	.084	2.5
230	690	.072	2.5	500	.083	2.5	500	.084	2.5
136	86	.048	1.5	76	.056	1.5	1,100	.064	1.5
236	86	.048	1.5	76	.056	1.5	1,100	.064	1.5
148	160	.11	2.3	120	.136	2.4	111	.15	2.5
248	160	.11	2.3	120	.136	2.4	111	.15	2.5

* 1.88 x 10⁶

Air Tube Disc Clutches and Brakes

Air System Data

PSI pressure

Inflation

Clutch air pressure during inflation can be closely estimated by the following:

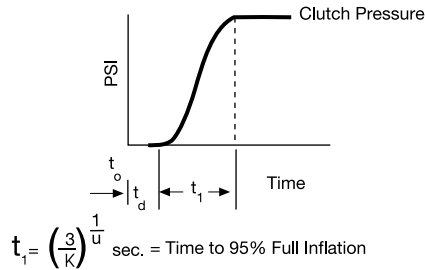

Clutch pressure = $P_1 \left(1 - \frac{1}{e^{Kt^U}}\right)$ PSI (inflation)

This equation is accurate from 5% up to 95% P_1 .

P_1 = Line pressure to clutch PSI

K and U = coefficients for specific clutch and air pressure from Specification Table on page 51.

e = Naperian base log

t_0 = Time at initiation of signal for inflation sec.

t_d = Time delay of air system – sec.

Exhaust

Clutch air pressure during exhaust can be closely estimated by the following:

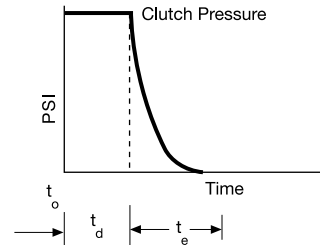

Clutch pressure = $(P_1) (R) (E-t)^V$ PSI (exhaust)

R , E and V = coefficients for specific clutch and air pressure from Specification Table on page 51.

t_e = Time to exhaust = E from Specification Table on page 51.

t = Time variable – seconds. In the exhaust equation “ t ” cannot exceed the value of “ E ” sec.

Shown are some of the air systems used on Wichita clutches. These systems are acceptable for remote operation where clutch reaction time is not important. Faster clutch reaction time is accomplished as indicated in the diagram by locating the flow control valve, if required, and the solenoid valve as close as possible to the roto-coupling. Where clutches are located on long shafts, the use of quick release valves on the clutch will facilitate faster clutch response.

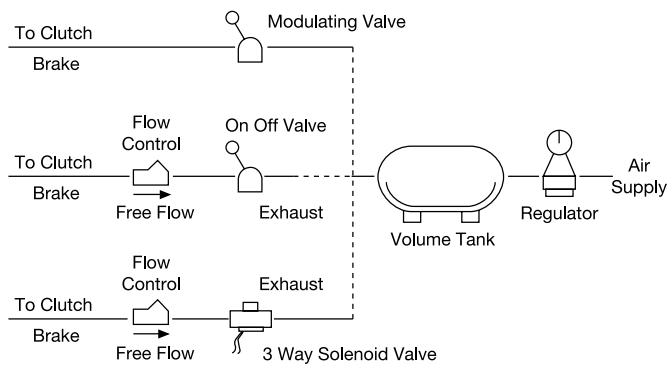

Air Tube Disc Clutches and Brakes

Air System Data

PSI pressure

Overlap

A typical clutch-brake torque curve for a single backshaft press (cyclic application) would appear as shown below.

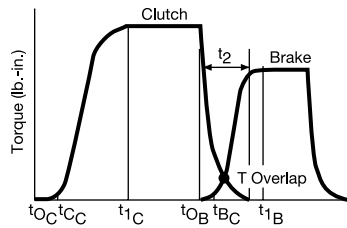

Time (sec.)

- t_{0c} = time at which disengaged clutch receives signal
- t_{cc} = time of clutch engagement
- t_{1c} = time of clutch full inflation
- t_{0b} = time at which disengaged brake receives signal
- t_{bc} = time of brake engagement
- t_{1b} = time of brake full exhaust
- t_2 = overlap time at which clutch and brake are both engaged

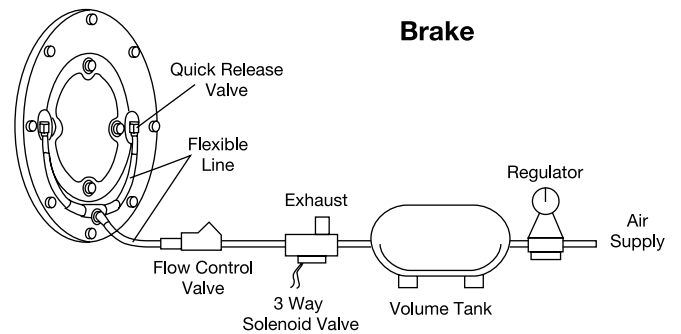
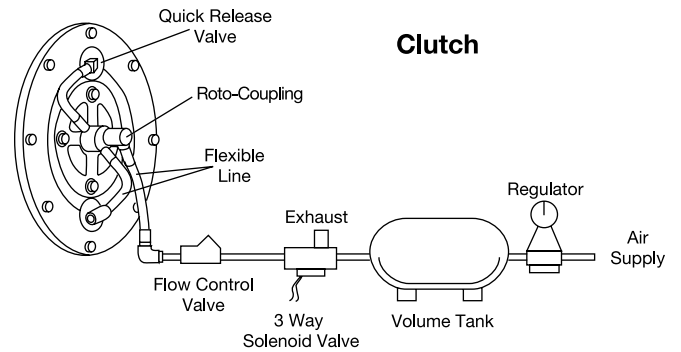

Air Tube Disc Clutches and Brakes

High Torque Clutches

Sizes 4-24

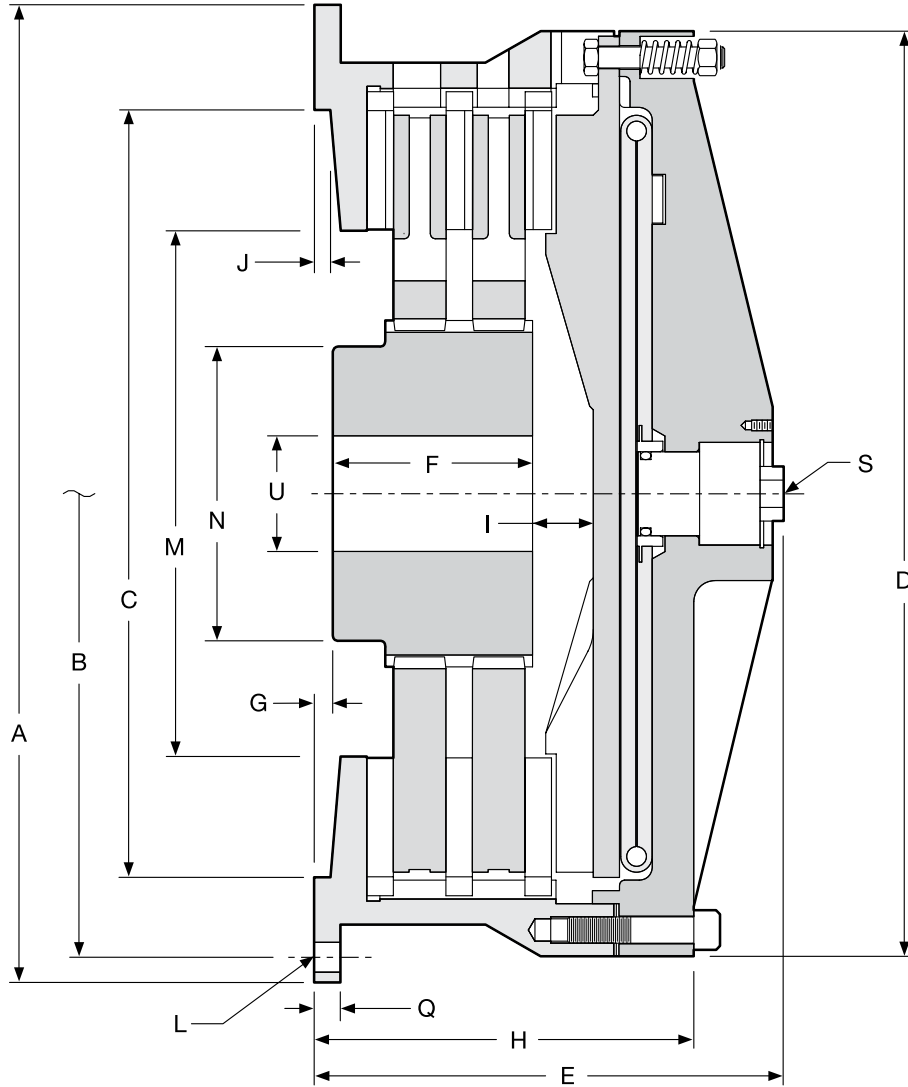

Air Tube Disc Clutches and Brakes

High Torque Clutches

Sizes 4-24

Dimensions: inches (mm)

Model Size ATD-	A	B Hole Circle	C Pilot	D	E	F	G	H
HTC 104 ²	7.38	6.875	4.375 / 4.378	6.38	3.38 (85.9)	1.00 (25.4)	0.06 (1.5)	2.50 (63.5)
HTC 204 ²	(187.5)	(174.63)	(111.13 / 111.20)	(162.1)	2.50 (63.5)	1.88 (47.8)	0.00 (0.0)	3.19 (81.0)
HTC 106 ³	8.75	8.000	7.377 / 7.379	8.81	5.03 (127.8)	2.00 (50.8)	0.00 (0.0)	4.53 (115.1)
HTC 206	(222.3)	(203.20)	(187.38 / 187.43)	(223.8)	6.25 (158.8)	3.25 (82.6)	0.06 (1.5)	5.75 (146.1)
HTC 108 ¹	12.13	11.125	8.375 / 8.378	11.13	6.21 (157.7)	1.50 (38.1)		4.37 (111.0)
HTC 208 ¹	(308.1)	(282.58)	(212.73 / 212.80)	(282.7)	7.52 (191.0)	2.88 (73.2)	0.50 (12.7)	5.68 (144.3)
HTC 111 ¹	16.00	14.750	11.375 / 11.378	14.75	7.82 (198.6)	2.00 (950.8)		5.44 (138.2)
HTC 211 ¹	(406.4)	(374.65)	(288.93 / 289.00)	(374.7)	9.63 (244.6)	3.75 (95.3)	0.50 (12.7)	7.25 (184.2)
HTC 114 ¹					8.39 (213.1)	3.75 (95.3)	.13 (3.3)	6.06 (153.9)
HTC 214	18.75	17.500	14.375 / 14.378	17.50	10.50 (266.7)	4.50 (114.3)	.38 (9.7)	7.88 (200.2)
HTC 314 ³	(476.3)	(444.50)	(365.13 / 365.20)	(444.5)	10.00 (254.0)	4.50 (114.3)	.38 (9.7)	7.88 (200.2)
HTC 116					9.16 (232.7)	2.75 (69.9)		6.78 (172.2)
HTC 216	21.25	20.000	16.250 / 16.253	20.00	11.16 (283.5)	4.75 (120.7)	0.38 (9.7)	8.66 (220.0)
HTC 316	(539.8)	(508.00)	(412.75 / 412.83)	(508.0)	13.06 (331.7)	6.63 (168.4)		10.69 (271.5)
HTC 118					9.28 (235.7)	2.75 (69.9)		7.16 (181.9)
HTC 218	23.25	22.000	18.250 / 18.253	22.00	11.20 (283.5)	4.75 (120.7)	0.44 (11.2)	9.03 (229.4)
HTC 318	(590.6)	(558.80)	(463.55 / 463.63)	(558.8)	12.81 (325.4)	6.50 (165.1)		10.94 (277.9)
HTC 121					10.19 (258.8)	2.88 (73.2)	0.69 (17.5)	7.56 (192.0)
HTC 221	27.00	25.500	21.375 / 21.378	24.88	11.83 (300.5)	5.13 (130.3)	0.75 (19.1)	9.69 (246.1)
HTC 321	(685.8)	(647.70)	(542.93 / 543.00)	(632.0)	14.19 (360.4)	7.13 (181.1)	0.75 (19.1)	12.06 (306.3)
HTC 124					10.06 (255.5)	3.50 (88.9)	0.38 (9.7)	8.38 (212.9)
HTC 224	30.00	28.750	24.375 / 24.378	28.00	12.38 (314.5)	3.50 (88.9)	0.75 (19.1)	10.69 (271.5)
HTC 324	(762.0)	(730.25)	(619.13 / 619.20)	(711.2)	14.69 (373.1)	5.13 (130.3)	0.75 (19.1)	13.00 (330.2)
HTC 424 ³	29.00	26.75	25.500 / 25.503	28.00	15.64 (397.3)	8.38 (212.9)	0.72 (18.3)	13.81 (350.8)
	(736.6)	(679.5)	(647.70 / 647.78)	(711.2)				

Dimensions: inches (mm)

Model Size ATD-	I	J	L		M	N	Q	S	U	
			No.-	Size					Min.	Max.
HTC 104	.38 (9.7)								0.50	1.00
HTC 204	.63 (16)	0.13 (3.3)	6 -	9/32 (7.1)	2.88 (73.2)	2.58 (65.5)	0.38 (9.7)	5/8-18NF	(12.7)	(25)
HTC 106	.94 (23.9)								1.00	2.00
HTC 206	.82 (20.8)	0.06 (1.5)	4 -	11/32 (8.7)	4.19 (106.4)	2.69 (68.3)	0.56 (14.2)	5/8-18NF	(25)	(50.8)
HTC 108	.81 (20.6)								1.00	2.38
HTC 208	.75 (19.1)	0.25 (6.4)	6 -	17/32(13.5)	5.38 (136.7)	3.62 (91.9)	0.50 (12.7)	1/4 NPT	(25)	(60.5)
HTC 111	1.06 (26.9)								1.00	2.63
HTC 211	1.12 (28.4)	0.38 (9.7)	6 -	11/16 (17.5)	7.00 (177.8)	4.12 (104.6)	1.13 (28.7)	1/2 NPT	(25)	(66.8)
HTC 114	1.06 (26.9)	.38 (9.7)								4.13 (104.9)
HTC 214	.81 (20.6)	.38 (9.7)	8 -	21/32 (16.7)	9.44 (239.8)	5.50 (139.7)	0.63 (16.0)	1/2 NPT	1.38	3.63 (92.2)
HTC 314	.94 (23.9)	.13 (3.3)		5/8-11NC	9.50 (241.3)	6.66 (169.2)	—		(35.1)	4.63 (117.6)
HTC 116	1.25 (31.8)			11/16 (17.5)					1.38	4.00
HTC 216	1.25 (31.8)	0.38 (9.7)	12 -	21/32 (16.7)	10.50 (266.7)	6.00 (152.4)	0.63 (16.0)	1/2 NPT	(35.1)	(101.6)
HTC 316	1.13 (28.7)			21/32 (16.7)						
HTC 118				21/32 (16.7)						
HTC 218	1.44 (36.6)	0.38 (9.7)	12 -	11/16 (17.5)	12.50 (317.5)	7.00 (177.8)	0.63 (16.0)	1/2 NPT	2.00	4.75
HTC 318				21/32 (16.7)					(50.8)	(120.7)
HTC 121	1.50 (38.1)									
HTC 221	1.31 (33.3)	0.31 (7.9)	12 -	21/32 (16.7)	14.50 (368.3)	9.00 (228.6)	0.75 (19.1)	1/2 NPT	2.00	6.00
HTC 321	1.44 (36.6)								(50.8)	(152.4)
HTC 124	1.13 (28.7)									
HTC 224	1.38 (35.1)	0.25 (6.4)	12 -	21/32(16.7)	14.50 (368.3)	9.00 (228.6)	0.75 (19.1)	1/2 NPT	2.00	6.00
HTC 324	1.56 (39.6)								(50.8)	(152.4)
HTC 424 ³	1.56 (39.6)	0.13 (3.3)	12 -	5/8-11NC	14.50 (368.3)	9.00 (228.6)	—	1/2 NPT	2.00 (50.8)	6.00 (152.4)

Note: For mounting, use socket head capscrews conforming to the ASTM-574-97a.

¹ Non-Ventilated center plate, "centerplate is solid".

² Drive plate assembly, "friction material is attached to a drive plate".

³ Less backplate.

(Consult factory for drawing before final layout.)

Air Tube Disc Clutches and Brakes

High Torque Clutches

Sizes 27-48

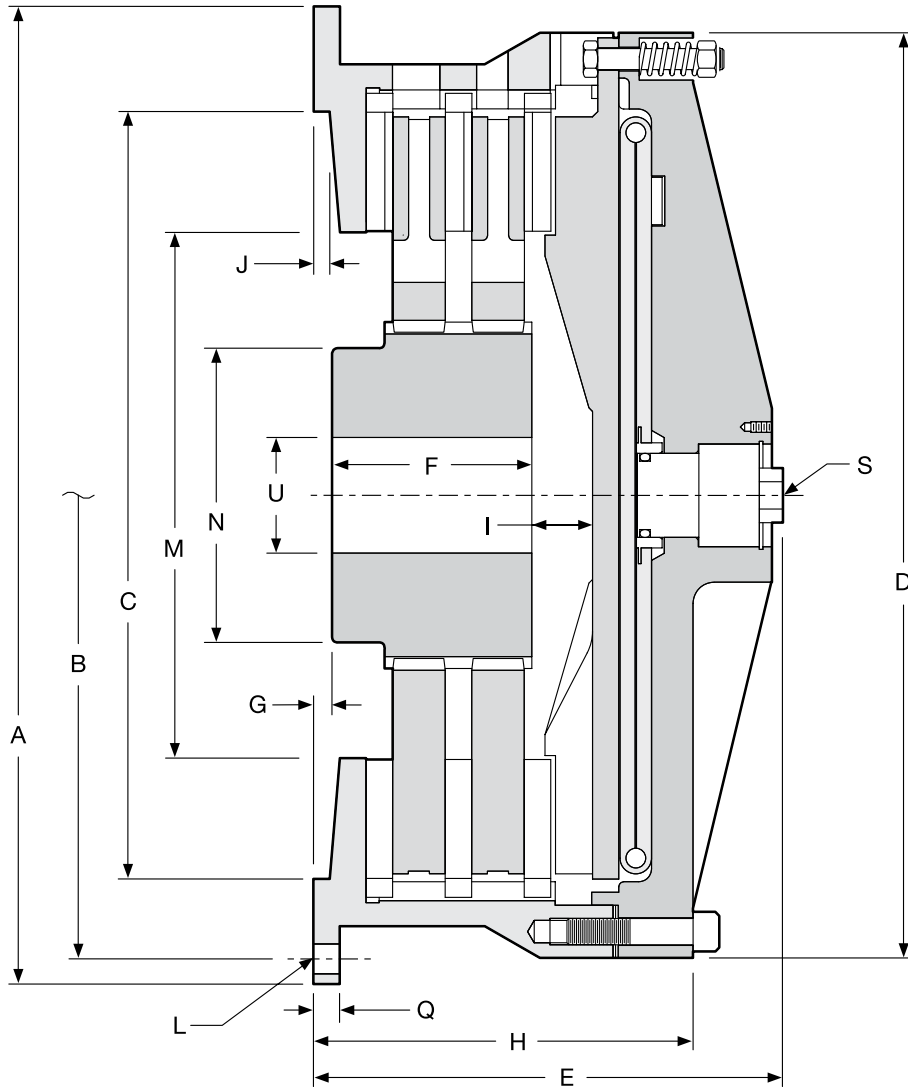

Air Tube Disc Clutches and Brakes

High Torque Clutches

Sizes 27-48

Dimensions: inches (mm)

Model Size ATD-	A	B Hole Circle	C Pilot	D	E	F	G	H
HTC 127	32.75	31.500	27.375 / 27.378	31.00	10.34 (262.6)	3.50 (88.9)		8.50 (215.9)
HTC 227	(831.9)	(800.10)	(695.33 / 695.40)	(787.4)	12.75 (323.9)	5.50 (139.7)	0.75 (19.1)	10.91 (277.1)
HTC 327					15.39 (390.9)	7.94 (201.7)		13.34 (338.8)
HTC 130	37.00	35.500	30.375 / 30.378	36.13	11.44 (290.6)	4.25 (108.0)		10.06 (255.5)
HTC 230	(939.8)	(901.70)	(771.53 / 771.60)	(917.7)	14.75 (374.7)	7.50 (190.5)	0.75 (19.1)	13.38 (339.9)
HTC 330					16.25 (412.8)	9.50 (241.3)		15.13 (384.3)
HTC 136	43.50	42.000	36.375 / 36.378	41.50	11.88 (301.8)	4.13 (104.9)	1.13 (28.7)	11.63 (295.4)
HTC 236	(1,104.9)	(1,066.80)	(923.93 / 924.00)	(1,054.1)	15.31 (388.9)	7.50 (190.5)	1.13 (28.7)	15.06 (382.5)
HTC 336					18.75 (476.3)	10.75 (273.1)	1.25 (31.8)	18.50 (469.9)
HTC 148	61.00	58.000		59.00	26.44(671.6)	6.00 (152.4)	1.00 (25.4)	17.13 (435.1)
	(1,525.0)	(1,473.2)		(1,498.6)				
HTC 248	62.00	60.000	52.000 / 52.005	57.00	30.12 (765.0)	8.75(222.3)	1.75 (44.5)	20.81(528.6)
	(1,574.8)	(1,524.0)	(1,320.8 / 1,320.9)	(1,447.8)				
HTC 348 ¹	61.00	58.000		59.00	23.44 (595.4)	12.63 (320.8)	0.00 (0.0)	23.44 (595.4)
	(1,525.0)	(1,473.2)		(1,498.6)				

Dimensions: inches (mm)

Model Size ATD-	I	J	L		M	N	Q	S	U	
			No. -	Size					Min.	Max.
HTC 127	1.50 (38.1)					10.50 (266.7)		1/2 NPT		6.50 (165.1)
HTC 227	1.63 (41.4)	0.25 (6.4)	16 -	21/32 (16.7)	16.25 (412.8)	10.50 (266.7)	.75 (19.1)	1 NPT	2.50	6.50
									(63.5)	
HTC 327	1.63 (41.4)					9.00 (228.6)		1-1/2 -12NF		6.00 (152.4)
HTC 130	1.38 (35.1)					11.00 (279.4)		1/2 NPT		7.25 (184.2)
HTC 230	1.38 (35.1)	0.25 (6.4)	18 -	25/32 (19.8)	19.25 (489)	11.00 (279.4)	.75 (19.1)	1/2 NPT	2.50	7.25 (184.2)
									(63.5)	
HTC 330	1.00 (25.4)					12.00 (304.8)		1-1/2 -12NF		8.00 (203.2)
HTC 136						12.00 (304.8)				8.00 (203.2)
HTC 236	1.50 (38.1)	0.25 (6.4)	18-	1-1/32 (26.2)	23.63 (600.2)	12.00 (304.8)	1.50 (38.1)	1/2 NPT	6.00	8.00 (203.2)
									(152.4)	
HTC 336						14.00 (355.6)				9.25 (235.0)
HTC 148	2.70 (68.6)	0.25 (6.4)	24 -	1-1/16 (27.0)	32.00 (812.8)	25.75 (654.1)	1.75 (44.5)	2 NPT	6.00	18.00 (457.2)
									(152.4)	
HTC 248	3.44 (87.4)						1.50 (38.1)			
HTC 348 ¹	3.96 (100.6)	0.23 (5.8)	24 -	1-9/32 (32.5)	31.88 (809.8)	24.00 (609.6)	1.50 (38.1)	2-1/2 NPT	6.00	18.00 (457.2)
									(152.4)	

NOTE: For mounting, use socket head capscrews conforming to the ASTM-574-97a.

¹ Less backplate.

(Consult factory for drawing before final layout.)

Air Tube Disc Clutches and Brakes

Spring-Set Air Release Brakes

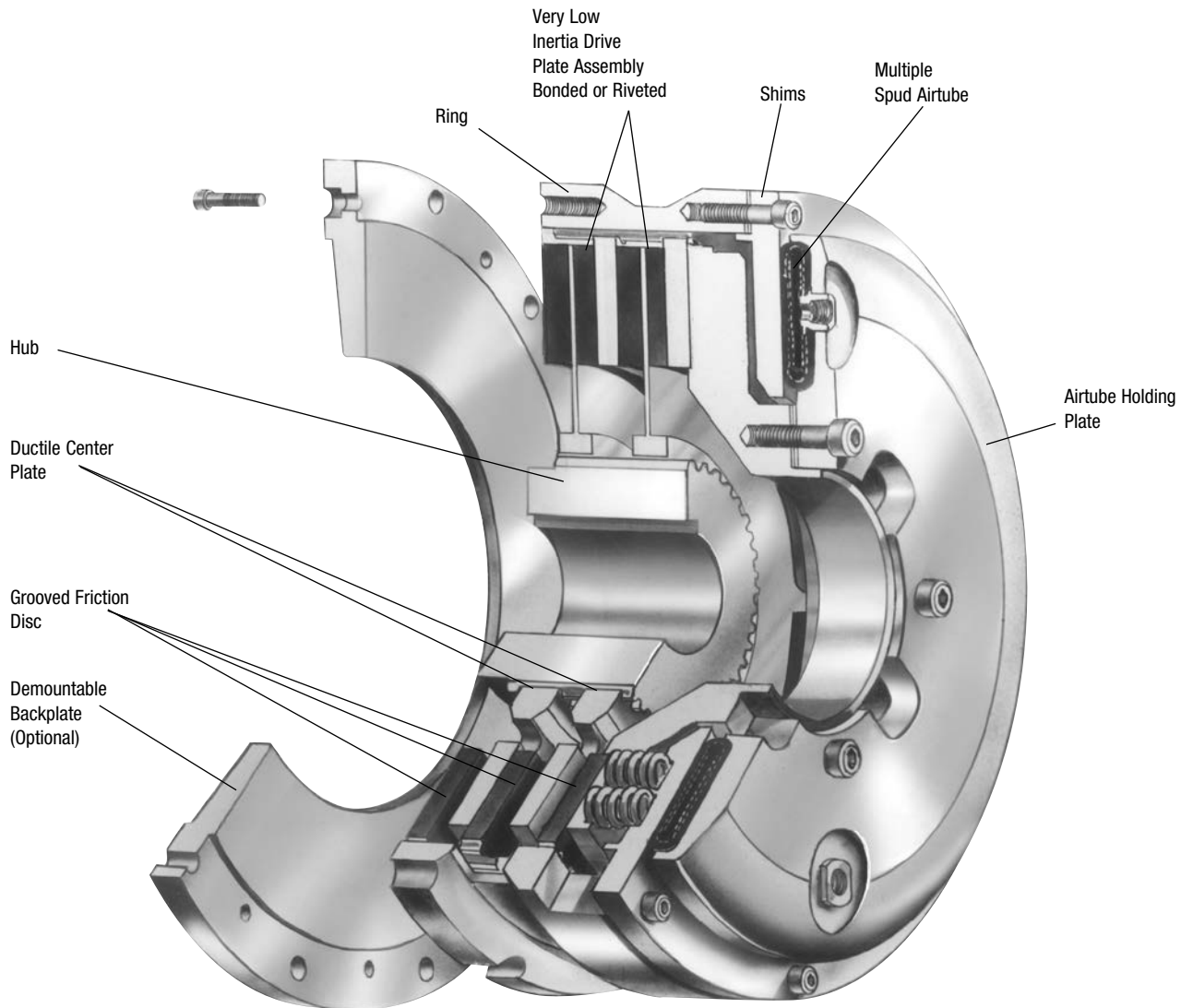

Wichita Spring-Set Air Release Brakes are ideal for fail safe protection of process equipment. Constructed of high strength cast iron, this improved design has thick friction discs for longer wear life. The fast acting air-tube design assures quick, smooth stops.

- No lubrication
- No adjustment
- Available in vertical mount
- Quick, simple installation
- Explosion proof design

Selection requirements

The selection of a Low Inertia Brake is based on:

1. Torque required to stop a load
2. Friction area necessary to absorb rotational energy
3. Contact velocity of rotating discs
4. Maximum bore capacity of unit

Low Inertia Spring-Set Brake

To properly select a brake, the total rotating inertia, WR^2 , must be reflected to the brak shaft.

Application Data:

Refer to page 45, except, cyclic operation—7 CPM, and 218 Very Low Inertia Clutch.

Alternate Shaft WR^2 referred to clutch shaft =

$$(\text{Alternate Shaft } WR^2) \left(\frac{\text{Alternate Shaft RPM}}{\text{Clutch Brake Shaft RPM}} \right)^2$$

WR^2 referred to clutch-brake shaft

$$= (39,091) \left(\frac{30}{204} \right)^2$$

WR^2 referred to clutch-brake shaft

$$= 845.4 \text{ lb.ft.}^2 @ 204 \text{ RPM}$$

$$\text{Crank Shaft } WR^2 = 845.4 \text{ lb.ft.}^2$$

$$\text{Clutch-Brake Shaft } WR^2 = 78.2 \text{ lb.ft.}^2$$

$$\text{Clutch Hub and Drive Plate } WR^2 \text{ from Specification Table = } 14.7 \text{ lb.ft.}^2 \text{ (page 61)}$$

$$\text{Est. Brake } WR^2 = 14.7 \text{ lb.ft.}^2$$

$$\text{Est. Total } WR^2 = 953.0 \text{ lb.ft.}^2$$

Brake Selection:

Stopping angle of crank shaft = $120^\circ = \phi_b$
Use 90° for calculation

Estimated time to stop:

$$t = \left(\frac{\phi_b}{360^\circ} \right) \left(\frac{60}{\text{crank shaft RPM}} \right)$$

$$= \left(\frac{90}{360} \right) \left(\frac{60}{30} \right) = .5 \text{ sec.}$$

Deceleration Torque

$$= (12) \left(\frac{WR^2}{32.2} \right) \left(\frac{\text{clutch-brake RPM}}{(9.5) (t)} \right)$$

$$= (12) \left(\frac{953}{32.2} \right) \left(\frac{204}{(9.5) (.5)} \right)$$

$$= 15,250 \text{ lb.in.}$$

HP/100 RPM

$$= \frac{15,250}{630} = 24 \text{ HP/100 RPM}$$

From duty chart (page 23) "Group B" for spring-set brake (SS):

214 SS Brake is rated @ 28 HP/100 RPM
90% torque rating = 24,800 lb.in.

WR^2 of 214 SS VLI Brake = 4.5 lb.ft.², therefore deceleration torque calculation is correct.

*Average heat horsepower to clutch & brake.

$$\text{Avg. heat HP} = \frac{(\text{Total } WR^2) (\text{RPM}^2) (\text{CPM})}{1.9 \times 10^8}$$

$$= \frac{(953) (41,616) (7)}{1.9 \times 10^8} = 1.45 \text{ HP}$$

*Check with factory for heat capacity.

Note:

This application example is for preliminary sizing only. Contact a Wichita Sales Engineer or the factory for final selection.

Air Tube Disc Clutches and Brakes

Spring-Set Brakes

Specifications

Model Size ATD-	Assembly Number 60 PSI Release	Slip Torque Capacity						Max. Bore Rect. Key	
		60 PSI	lb.in. 75 PSI	90 PSI	4.1 BAR	Nm 5.2 BAR	6.2 BAR	in.	(mm)
SSB 104H	71104-730*	451				51			1.00 (25)
SSB 106	7-106-100-200-0	2,225	2,900	3,700	251	328	418		
SSB 206	7-106-200-200-0	4,300	5,600	7,200	486	633	813	2.00	(50)
SSB 306	7-106-300-100-0*	5,750	7,400	9,050	650	836	1,022		
SSB 108	7-108-100-123-0	3,700	4,800	6,200	418	542	700		
SSB 208	7-108-200-121-0	7,100	9,100	12,000	802	1,028	1,356	2.25	(57)
SSB 308	7-108-300-101-0	8,800	11,300	13,400	994	1,277	1,514		
SSB 111	7-111-100-102-0	8,200	10,500	11,600	926	1,186	1,311		
SSB 211	7-111-200-100-0	15,600	20,000	22,200	1,763	2,260	2,508	2.50	(64)
SSB 311	7-111-300-100-0	19,300	24,900	28,400	2,181	2,813	3,209		
SSB 114	7-114-100-127-0	14,500	18,600	24,700	1,638	2,101	2,791		
SSB 214	7-114-200-103-0	27,600	35,400	46,300	3,118	4,000	5,231	3.50	(89)
SSB 314	7-114-300-100-0	36,000	44,700	53,900	4,067	5,050	6,090		
SSB 116	7-116-100-100-0	19,300	23,800	28,400	2,181	2,689	3,209		
SSB 216	7-116-200-100-0	35,300	44,700	53,400	3,988	5,050	6,033	4.00	(102)
SSB 316	7-116-300-100-0	49,500	62,600	75,000	5,593	7,073	8,474		
SSB 118	7-118-100-100-0	31,400	40,400	51,600	3,548	4,564	5,830		
SSB 218	7-118-200-100-0	60,000	77,000	100,000	6,779	8,700	11,298	4.75	(120)
SSB 318	7-118-300-100-0	80,900	102,000	122,000	9,140	11,524	13,784		
SSB 121	7-121-100-100-0	38,300	47,400	57,400	4,327	5,355	6,485		
SSB 221	7-121-200-100-0	71,700	88,800	107,600	8,101	10,033	12,157	6.00	(152)
SSB 321	7-121-300-101-0	100,200	124,100	150,400	11,321	14,021	16,992		
SSB 124H	7-125-100-100-0	75,500	86,600	—	8,530	9,784	—		
SSB 224H	7-125-200-100-0	137,000	161,200	—	15,478	18,213	—	6.00	(152)
SSB 324H	7-125-300-100-0	178,900	223,600	—	20,212	25,263	—		
SSB 127	7-127-100-105-0	75,300	94,200	113,400	8,508	10,643	12,812		
SSB 227	7-127-200-118-0	140,900	176,200	212,100	15,919	19,907	23,963	6.50	(165)
SSB 327	7-127-300-102-0	196,700	245,900	296,000	22,223	27,782	33,443		
SSB 130H	7-131-100-101-0	162,200	211,700	260,500	18,326	23,918	29,432		
SSB 230H	7-131-200-100-0	310,000	404,500	495,500	35,024	45,701	55,982	7.25	(184)
SSB 330H	7-131-300-305-0	395,500	496,100	589,900	44,684	56,050	66,648		
SSB 136H	7-137-100-100-0	254,500	300,000	400,000	28,754	33,894	45,193	9.00	(229)
SSB 236H	7-137-200-104-0	477,500	564,000	760,000	53,949	63,722	85,866	10.00	(254)
SSB 336H	7-137-300-101-0*	675,000	840,100	1,012,600	76,263	94,916	114,405	10.00	(254)
SSB 436H	7-137-400-102-0	868,800	1,081,300	1,303,400	98,158	122,167	147,260	10.00	(254)
SSB 142	7-142-100-302-0	425,000			48,017				
SSB 242	7-142-200-306-0	796,000			89,933			14.00	(355)
SSB 342	7-142-300-301-0	1,072,000			121,116				
SSB 148	7-148-100-300-0	698,250			78,889				
SSB 248	7-148-200-300-0	1,335,000			150,830			18.00	(455)
SSB 348	7-148-300-103-0	1,726,000			195,006				
SSB 260	7-160-200-300-0	3,255,000			367,755				
SSB 360	TBD	4,921,000			555,982			19.00	(480)
SSB 460	TBD	5,355,000			605,016				

* Not the standard 60 PSI release pressure. See following pages for release pressure per assembly.

Air Tube Disc Clutches and Brakes

Spring-Set Brakes Specifications

Model Size ATD-	Recom- mended Clearance in.	Balance Speed RPM	Hub & C.P.		Swept Area in. ²	Airtube Volume in. ³ (cm ³)		Total Brake Wt.		Hub & Center Plate Wt.			
			Reg- Speed RPM	High Speed RPM*		New	Worn	lb.	(kg)	lb.	(kg)	WR ² / J=mr ²	
												lb.ft. ²	kgm ²
SSB 104H	1/32-1/16	3,325	5,250	5,250*	17	0.9	3.4	11.0	(7)	1.54	(0.7)	0.021	(0.001)
SSB 106	1/16-3/32				39								
SSB 206	3/32-1/8	2,225	3,800	5,700*	78	1.8	11.9	27.5	(12)	6.40	(2.9)	0.24	(0.010)
SSB 306	3/32-1/8				117			40.5	(18)	12.17	(5.5)	0.46	(0.019)
SSB 108	1/16-1/8				56			62	(28)	11	(5.0)	0.54	(0.023)
SSB 208	3/32-5/32	1,675	2,870	4,300*	112	3.4	18.3	70	(32)	19	(8.6)	1.00	(0.042)
SSB 308	1/8-3/16				168	(56)	(300)	87	(39)	28	(12.7)	2.00	(0.084)
SSB 111	1/16-1/8				114			130	(59)	23	(10.4)	2.30	(0.097)
SSB 211	3/32-5/32	1,200	2,090	3,125*	228	5.5	30.5	166	(75)	45	(20.4)	4.50	(0.190)
SSB 311	1/8-3/16				342	(90)	(500)	208	(94)	121	(54.9)	7.00	(0.295)
SSB 114	1/16-1/8				158			184	(83)	46	(20.9)	5.7	(0.240)
SSB 214	3/32-5/32	950	1,640	2,450*	316	7.6	42.7	233	(106)	77	(34.9)	11.0	(0.464)
SSB 314	1/8-3/16				474	(125)	(700)	290	(132)	121	(54.9)	16.7	(0.704)
SSB 116	1/16-1/8				228			254	(115)	59	(26.8)	10.2	(0.430)
SSB 216	3/32-5/32	835	1,430	2,150*	455	9.8	56.1	326	(148)	106	(48.1)	19.6	(0.826)
SSB 316	1/8-3/16				683	(161)	(919)	358	(162)	151	(68.5)	29.6	(1.248)
SSB 118	1/16-1/8				264			311	(141)	73	(33.1)	15.0	(0.632)
SSB 218	3/32-5/32	750	1,270	1,910*	528	15.3	85.4	377	(171)	120	(54.4)	28.8	(1.214)
SSB 318	1/8-3/16				792	(251)	(1,400)	461	(209)	180	(81.6)	43.2	(1.821)
SSB 121	3/32-5/32				362			460	(209)	116	(52.6)	32	(1.35)
SSB 221	1/8-3/16	650	1,090	1,650*	724	18.3	97.6	575	(261)	198	(89.8)	61	(2.57)
SSB 321	5/32-7/32				1,086	(300)	(1,599)	723	(328)	312	(141.5)	122	(5.14)
SSB 124H	3/32-5/32				574			618	(280)	132	(60.0)	56	(2.4)
SSB 224H	1/8-3/16	550	950	1,410*	1,148	29.9	159	840	(381)	260	(117.9)	110	(4.6)
SSB 324H	5/32-7/32				1,722	(490)	(2,606)	1,025	(465)	379	(172.0)	160	(6.8)
SSB 127	3/32-5/32				730			760	(345)	187	(84.8)	98	(4.1)
SSB 227	1/8-3/16	500	850	1,250*	1,460	29.9	159	924	(419)	329	(149.2)	191	(8.1)
SSB 327	5/32-7/32				2,190	(490)	(2,606)	1,112	(504)	555	(251.7)	285	(12.0)
SSB 130H	3/32-5/32				827			972	(441)	298	(135.2)	189	(8.0)
SSB 230H	1/8-3/16	450	765	1,130*	1,654	58.6	311	1,350	(612)	546	(247.7)	370	(15.6)
SSB 330H	5/32-7/32				2,481	(960)	(5,096)	1,751	(794)	810	(367.4)	477	(20.1)
SSB 136H	3/32-5/32				1,150			1,388	(630)	461	(209.1)	372	(15.7)
SSB 236H	1/8-3/16	375	640	950*	2,300	110	415	1,993	(904)	708	(321.1)	725	(30.6)
SSB 336H	5/32-7/32				3,450	(1,803)	(6,801)	2,610	(1,184)	1,134	(514.4)	1,091	(46.0)
SSB 436H	3/16-1/4				4,600			4,025	(1,826)	1,600	(697)	1,457	(61.4)
SSB 142	5/32-7/32				1,400			1,967	(892)	680	(308)	705	(30)
SSB 242	3/16-1/4	325	545	805*	2,800	128	488	2,732	(1,239)	1,197	(543)	1,385	(58)
SSB 342	7/32-9/32				4,200	(2,098)	(7,997)	3,704	(1,680)	1,324	(601)	1,809	(76)
SSB 148	1/8-1/4				2,010			3,158	(1,432)	1,101	(499)	1,785	(75)
SSB 248	7/32-9/32	275	475	705*	4,020	217	824	4,700	(2,132)	1,942	(881)	3,335	(141)
SSB 348	3/16-5/16				6,030	(3,550)	(13,500)	6,540	(2,966)	2,950	(1,338)	4,925	(208)
SSB 260	3/16-5/16				7,230			9,453	(4,288)	2,567	(1,164)	7,077	(298)
SSB 360	1/4-3/8	225	380	575*	10,845	513	1,788	11,643	(5,281)	3,870	(1,755)	10,615	(448)
SSB 460	5/16-7/16				14,460	(8,407)	(29,300)	14,500	(6,577)	5,700	(2,585)	15,070	(635)

* Consult Factory for Special Assembly Number.

Air Tube Disc Clutches and Brakes

Specifications

Model Size ATD-	Release Pressure PSI	BAR	Assembly Number	Duty Factors HP/100 RPM			
				A	B	C	D
SSB 104H	65	4.5	71104-730	0.7	0.5	0.3	0.1
	60	4.1	7-106-100-200-0	3	2.3	1.2	0.6
SSB 106	75	5.2	7-106-100-216-0	4	3	1.5	0.8
	90	6.2	7-106-100-217-0	5	3.8	2	1
SSB 206	60	4.1	7-106-200-200-0	6	4.4	2.3	1.1
	75	5.2	7-106-200-205-0	8	5.7	3	1.5
SSB 306	90	6.2	7-106-200-206-0	10	7.4	3.9	2
	80	5.5	7-106-300-100-0	11.7	8.2	4.1	2.1
SSB 108	60	4.1	7-108-100-123-0	5.3	3.8	2	1
	75	5.2	7-108-100-124-0	7	5	2.6	1.3
SSB 208	90	6.2	7-108-100-125-0	9	6.3	3.3	1.6
	60	4.1	7-108-200-121-0	10	7.3	3.8	2
SSB 308	75	5.2	7-108-200-122-0	13	9.3	5	2.5
	90	6.2	7-108-200-110-0	17	12.3	6.5	3.2
SSB 111	60	4.1	7-108-300-101-0	14	9.8	4.9	2.4
	75	5.2	7-108-300-102-0	17.9	12.6	6.3	3.1
SSB 211	90	6.2	7-108-300-103-0	21.3	14.9	7.4	3.7
	60	4.1	7-111-100-102-0	11.7	8.4	4.4	2.2
SSB 311	75	5.2	7-111-100-120-0	15	10.7	5.7	2.8
	90	6.2	7-111-100-121-0	16.6	12	6.3	3.1
SSB 114	60	4.1	7-111-200-100-0	22	16	8.4	4.2
	75	5.2	7-111-200-126-0	28.6	20.5	11.0	5.4
SSB 214	90	6.2	7-111-200-127-0	35.2	24.7	12.3	6.2
	60	4.1	7-111-300-100-0	30.6	21.4	10.7	5.4
SSB 314	75	5.2	7-111-300-103-0	39.5	27.7	13.8	6.9
	90	6.2	7-111-300-104-0	45.1	31.6	15.8	7.9
SSB 116	60	4.1	7-114-100-127-0	20	15	6	4
	75	5.2	7-114-100-101-0	26.6	19	10	5
SSB 216	90	6.2	7-114-100-128-0	35	25	13	6.7
	60	4.1	7-114-200-103-0	39	28	15	7.5
SSB 316	75	5.2	7-114-200-108-0	50	36	19	9.5
	90	6.2	7-114-200-122-0	66	47	25	12.5
SSB 118	60	4.1	7-114-300-100-0	57.1	40	20	10
	75	5.2	7-114-300-104-0	71	49.7	24.8	12.4
SSB 218	90	6.2	7-114-300-105-0	85.6	59.9	29.9	15
	60	4.1	7-116-100-100-0	31	21	11	5
SSB 318	75	5.2	7-116-100-110-0	38	26	13	7
	90	6.2	7-116-100-111-0	45	32	16	8
SSB 110	60	4.1	7-116-200-100-0	56	39	20	10
	75	5.2	7-116-200-116-0	71	50	25	12
SSB 210	90	6.2	7-116-200-117-0	85	59	30	15
	60	4.1	7-116-300-100-0	79	55	28	14
SSB 310	75	5.2	7-116-300-101-0	99	50	25	12
	90	6.2	7-116-300-102-0	119	83	42	21
SSB 112	60	4.1	7-118-100-100-0	45	32	17	8.5
	75	5.2	7-118-100-136-0	58	41	22	11
SSB 212	90	6.2	7-118-100-137-0	74	53	28	14
	60	4.1	7-118-200-100-0	86	61	32	16
SSB 312	75	5.2	7-118-200-148-0	110	79	41	21
	90	6.2	7-118-200-149-0	143	102	54	27
SSB 114	60	4.1	7-118-300-100-0	128	90	45	22
	75	5.2	7-118-300-104-0	162	113	57	28
SSB 314	90	6.2	7-118-300-105-0	194	136	68	34

Air Tube Disc Clutches and Brakes

Specifications

Model Size ATD-	Release Pressure PSI	BAR	Assembly Number	Duty Factors HP/100 RPM			
				A	B	C	D
SSB 121	60	4.1	7-121-100-100-0	61	43	21	11
	75	5.2	7-121-100-106-0	75	53	26	13
	90	6.2	7-121-100-107-0	91	64	32	16
SSB 221	60	4.1	7-121-200-100-0	114	80	40	20
	75	5.2	7-121-200-118-0	141	99	49	25
	90	6.2	7-121-200-119-0	171	120	60	30
SSB 321	60	4.1	7-121-300-101-0	159	111	56	28
	75	5.2	7-121-300-102-0	197	138	69	34
	90	6.2	7-121-300-103-0	239	167	84	42
SSB 124H	60	4.1	7-125-100-100-0	108	77	41	20
	75	5.2	7-125-100-124-0	137	96	48	24
SSB 224H	60	4.1	7-125-200-100-0	196	140	74	37
	75	5.2	7-125-200-134-0	256	179	90	45
SSB 324H	60	4.1	7-125-300-100-0	284	199	99	50
	75	5.2	7-125-300-104-0	355	248	124	62
SSB 127	60	4.1	7-127-100-105-0	120	84	42	21
	75	5.2	7-127-100-100-0	150	105	53	26
	90	6.2	7-127-100-106-0	180	126	63	32
SSB 227	60	4.1	7-127-200-118-0	224	157	78	39
	75	5.2	7-127-200-100-0	280	196	98	49
	90	6.2	7-127-200-119-0	337	236	118	59
SSB 327	60	4.1	7-127-300-102-0	312	219	109	55
	75	5.2	7-127-300-100-0	390	273	137	68
	90	6.2	7-127-300-103-0	470	329	164	82
SSB 130H	60	4.1	7-131-100-101-0	232	166	88	44
	75	5.2	7-131-100-104-0	303	217	115	57
	90	6.2	7-131-100-105-0	372	267	141	70
SSB 230H	60	4.1	7-131-200-100-0	443	318	167	84
	75	5.2	7-131-200-110-0	578	415	218	110
	90	6.2	7-131-200-111-0	710	508	268	134
SSB 330H	60	4.1	7-131-300-305-0	628	439	220	110
	75	5.2	7-131-300-306-0	787	551	276	138
	90	6.2	7-131-300-307-0	936	655	328	164
SSB 136H	60	4.1	7-137-100-100-0	404	283	141	71
	75	5.2	7-137-100-101-0	476	333	167	83
	90	6.2	7-137-100-102-0	635	444	222	211
SSB 236H	60	4.1	7-137-200-104-0	758	531	265	133
	75	5.2	7-137-200-105-0	895	627	313	157
	90	6.2	7-137-200-106-0	1,206	844	422	211
SSB 336H	60	4.1	7-137-300-101-0	917	642	321	160
	75	5.2	7-137-300-102-0	1,155	808	404	202
	90	6.2	7-137-300-103-0	1,381	967	483	242
SBB 436H	60	4.1	7-137-400-102-0	1,616	1,132	564	284
	75	5.2	7-137-400-103-0	1,904	1,332	668	332
	90	6.2	7-137-400-104-0	2,540	1,776	888	444
SSB 142	60	4.1	7-142-100-302-0	610	435	230	115
SSB 242	60	4.1	7-142-200-306-0	1,140	815	430	215
SSB 342	60	4.1	7-142-300-301-0	1,702	1,192	596	298
SSB 148	60	4.1	7-148-100-300-0	1,000	715	375	190
SSB 248	60	4.1	7-148-200-300-0	1,910	1,370	720	360
SSB 348	60	4.1	7-148-300-103-0	2,740	1,918	959	479
SSB 260	60	4.1	7-160-200-300-0	4,650	2,340	1,760	880
SSB 360	60	4.1	—	7,030	4,050	2,660	1,330
SSB 460	60	4.1	—	8,500	5,950	2,975	1,488

B

Air Tube Disc Clutches and Brakes

Low Inertia Spring-Set Brake Component Parts

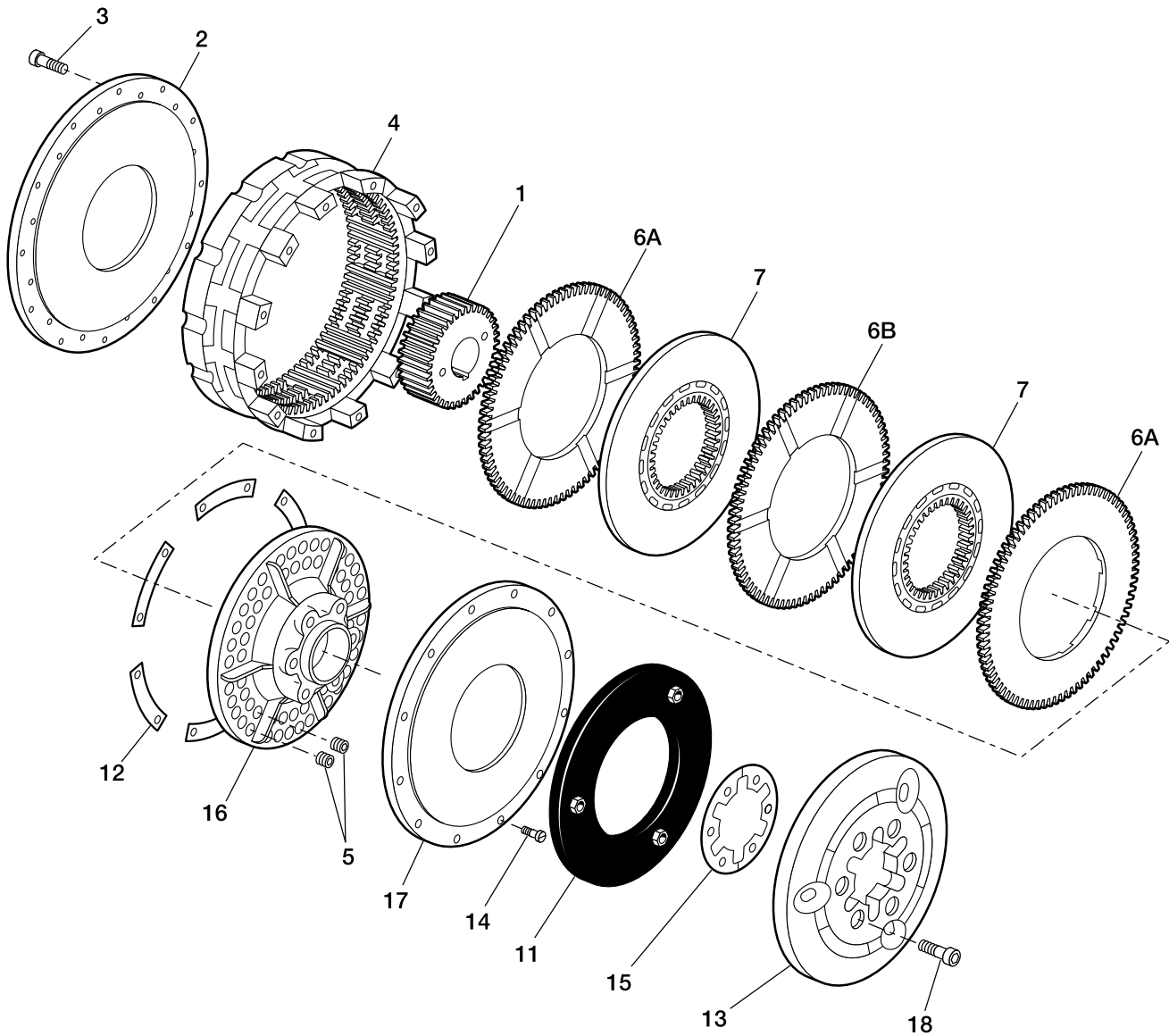

Component Parts

- | | |
|---|----------------------------|
| 1. Hub | 11. Airtube |
| 2. Backplate | 12. O. D. Shims |
| 3. Socket Head Capscrews | 13. Air Tube Holding Plate |
| 4. Ring | 14. Socket Head Capscrews |
| 5. Springs | 15. I.D. Shims |
| 6A. Grooved Friction Disc (grooved on one side) | 16. Spring Release Plate |
| 6B. Grooved Friction Disc (grooved on both sides) | 17. Airtube Spring Plate |
| 7. Center Plate | 18. Socket Head Capscrews |

Air Tube Disc Clutches and Brakes

Spring-Set Brake Air Hose Kits

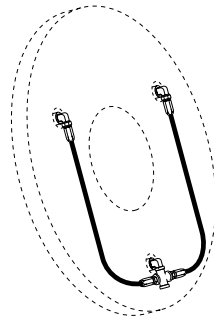
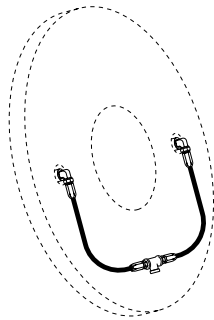
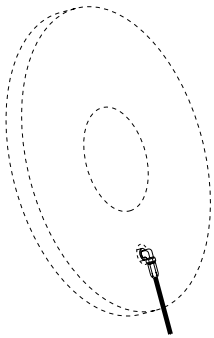

Model	Part Number
8"	8-908-912-100-5 8-908-924-100-5 QRV

Model	Part Number
6"	8-906-912-200-4 8-906-931-201-5 QRV
8"	8-908-913-200-5 8-908-931-200-5
11"	8-911-913-200-5 8-911-931-200-5 QRV
14"	8-914-913-200-5 8-914-921-200-5 QRV
16"	8-916-913-200-5 8-916-921-200-5 QRV

Model	Part Number
18"	8-918-912-200-5 8-918-931-200-5 QRV
21"	8-921-913-200-5 8-921-931-200-5 QRV
24"	8-924-913-200-5 8-924-931-200-5 QRV
27"	8-927-913-200-5 8-927-921-200-5 QRV

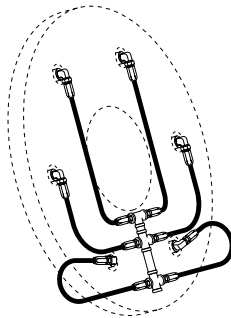
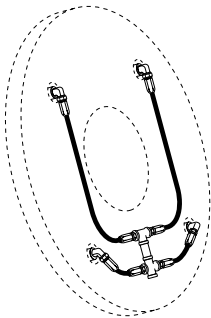

Air hose kits contain all necessary parts (fittings, hoses and extensions) to completely plumb the brake air system.

Optional Quick Release Valves can replace elbows on most units (see page 121).

Model	Part Number
30"	8-930-913-400-5 8-930-931-400-5 QRV
36"	8-936-913-400-6 8-936-931-400-6 QRV
42"	8-942-913-400-6 8-924-931-400-6 QRV
48"	8-948-912-400-6 8-948-923-400-6 QRV

Model	Part Number
60"	8-960-912-500-5 8-960-923-400-6 QRV



Air Tube Disc Clutches and Brakes

Spring-Set Brakes (Sizes 4H, 8-36)

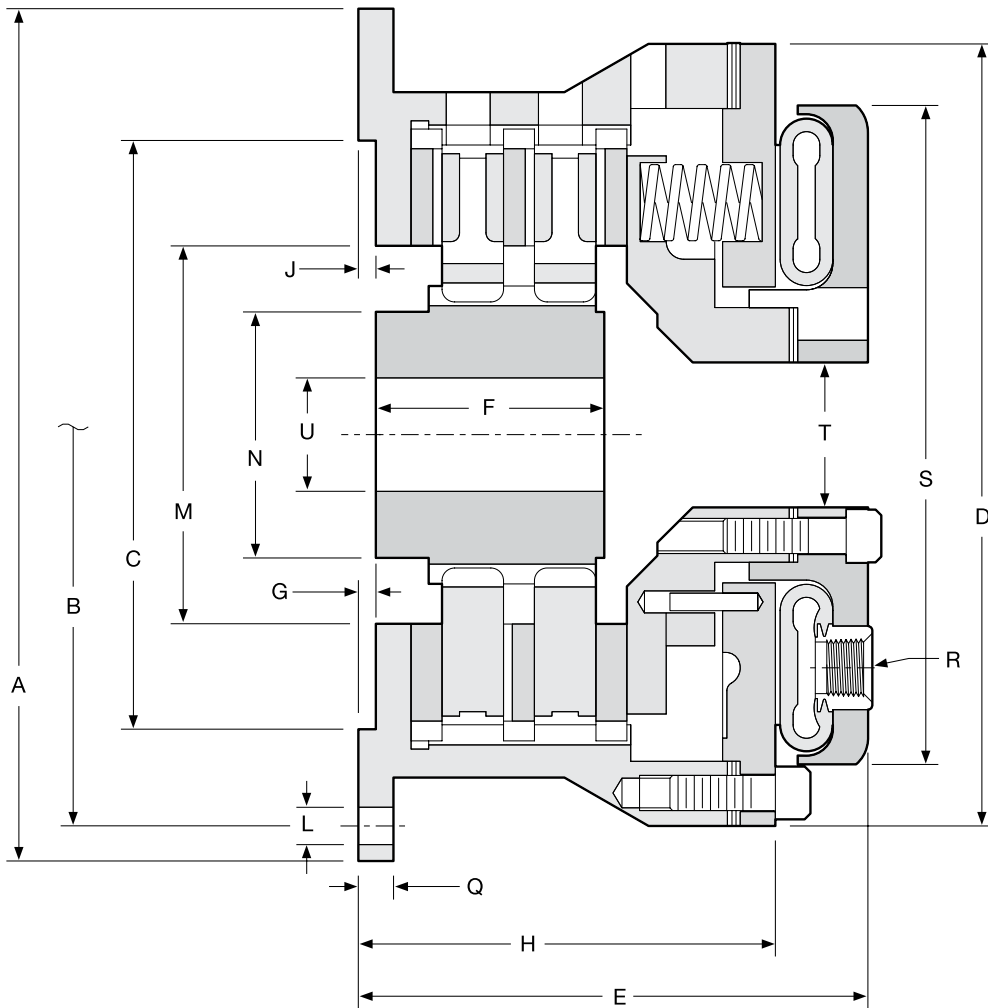

Air Tube Disc Clutches and Brakes

Dimensions: inches (mm)

Model Size ATD-	A	B Hole Circle	C Pilot	D	E	F	G	H
SSB 104H	7.09 (180)	6.496 (165)	5.512 / 5.515 (140.00 / 140.06)	7.09 (180)	4.13 (105)	0.98 (25)	0.06 (1.6)	3.78 (96)
SSB 108	12.13 (308.1)	11.125 (282.58)	8.375 / 8.378 (212.73 / 212.80)	11.13 (282.7)	5.88 (149.4)	2.00 (50.8)	0.25 (6.4)	4.56 (115.8)
SSB 208	16.00 (406.4)	14.750 (374.65)	11.375 / 11.378 (288.93 / 289.00)	14.75 (374.7)	6.56 (166.6)	2.75 (69.9)	0.13 (3.3)	5.44 (138.2)
SSB 111	18.75 (476.3)	17.500 (444.50)	14.375 / 14.378 (365.13 / 365.20)	17.50 (444.5)	8.00 (203.2)	3.00 (76.2)	0.13 (3.3)	6.00 (152.4)
SSB 211	21.25 (539.8)	20.000 (508.00)	16.250 / 16.253 (412.75 / 412.83)	20.00 (508.0)	8.25 (209.6)	4.00 (101.6)	0.38 (9.7)	6.00 (152.4)
SSB 114	23.25 (590.6)	22.000 (558.80)	18.250 / 18.253 (463.55 / 463.63)	22.00 (558.8)	10.06 (255.5)	4.75 (120.7)	0.38 (9.7)	7.87 (199.9)
SSB 214	27.00 (685.8)	25.500 (647.70)	21.375 / 21.378 (542.93 / 543.00)	24.88 (632.0)	12.13 (308.1)	6.63 (168.4)	—	9.88 (251.0)
SSB 314	30.00 (762)	28.750 (730.25)	24.375 / 24.378 (619.13 / 619.20)	29.00 (736.6)	9.00 (228.6)	4.00 (101.6)	0.44 (11.2)	6.56 (166.6)
SSB 116	32.75 (831.9)	31.500 (800.10)	27.375 / 27.378 (695.33 / 695.40)	31.00 (787.4)	10.70 (271.8)	4.75 (120.7)	0.44 (11.2)	8.45 (214.6)
SSB 216	37.00 (939.8)	35.500 (901.70)	30.375 / 30.378 (771.53 / 771.60)	34.75 (882.7)	—	—	—	—
SSB 316	43.50 (1,104.9)	42.000 (1,066.80)	36.375 / 36.378 (923.93 / 924.00)	41.00 (1,041.4)	9.69 (241.6)	4.00 (101.6)	0.75 (19.1)	7.38 (187.5)
SSB 118	—	—	—	—	11.88 (301.8)	5.13 (130.3)	0.75 (19.1)	9.57 (243.1)
SSB 218	—	—	—	—	—	—	—	—
SSB 318	—	—	—	—	—	—	—	—
SSB 121	—	—	—	—	9.56 (242.8)	4.00 (101.6)	0.75 (19.1)	6.50 (165.1)
SSB 221	—	—	—	—	11.88 (301.8)	5.13 (130.3)	0.81 (20.6)	9.50 (241.3)
SSB 321	—	—	—	—	—	—	—	—
SSB 124H	—	—	—	—	9.94 (252.5)	4.50 (114.3)	—	7.69 (195.3)
SSB 224H	—	—	—	—	12.5 (317.5)	6.88 (174.8)	0.75 (19.1)	10.13 (257.3)
SSB 324H	—	—	—	—	15.25 (387.4)	7.94 (201.7)	—	12.56 (319.0)
SSB 127	—	—	—	—	11.00 (279.4)	5.00 (127.0)	0.63 (16)	8.31 (211.1)
SSB 227	—	—	—	—	14.75 (374.7)	7.13 (181.1)	1.88 (47.8)	11.75 (298.5)
SSB 327	—	—	—	—	—	—	—	—
SSB 130H	—	—	—	—	11.75 (298.5)	4.25 (108.0)	0.63 (16)	8.56 (217.4)
SSB 230H	—	—	—	—	15.13 (384.3)	9.00 (228.6)	0.63 (16)	12.00 (304.8)
SSB 330H	—	—	—	—	19.06 (484.1)	12.38 (314.5)	1.00 (25.4)	15.81 (401.6)

Dimensions: inches (mm)

Model Size ATD-	J	L No. - Size	M	N	Q	R No. - Size	S	T	U Min. Max.
SSB 104H	0.19 (4.7)	4 - 0.35 (9)	2.99 (76)	1.97 (50)	2.13 (54)	2 - 1/8 NPT	7.09 (180)	1.97 (50)	0.60 (15) 1.00 (25)
SSB 108	0.25 (6.4)	6 - 17/32 (13.5)	5.38 (136.7)	3.50 (88.9)	0.50 (12.7)	2 - 1/2 NPT	9.38 (238.3)	2.06 (52.3)	1.00 (25) 2.00 (50.8)
SSB 111	0.38 (9.7)	6 - 21/32 (16.7)	7.00 (177.8)	4.00 (101.6)	0.63 (16)	2 - 1/2 NPT	11.94 (303.3)	3.02 (76.7)	1.00 (25) 2.50 (63.5)
SSB 114	0.38 (9.7)	8 - 21/32 (16.7)	9.44 (239.8)	5.50 (139.7)	0.63 (16)	2 - 1/2 NPT	14.38 (365.3)	3.88 (98.6) 4.25 (108) 3.88 (98.6)	1.38 (35.1) 3.50 (88.9)
SSB 116	0.38 (9.7)	11/16 (17.5)	10.50 (266.7)	6.00 (152.4)	0.63 (16)	2 - 1/2 NPT	16.30 (414)	4.38 (111.3)	1.38 (35.1) 4.00 (101.6)
SSB 216	0.38 (9.7)	12 - 11/16 (17.5)	12.50 (317.5)	7.00 (177.8)	0.63 (16)	3 - 1/2 NPT	19.38 (492.3)	4.88 (124)	2.00 (50.8) 4.75 (120.7)
SSB 316	0.38 (9.7)	21/32 (16.7)	14.50 (368.3)	9.00 (228.6)	0.75 (19.1)	3 - 1/2 NPT	21.31 (541.3)	6.25 (158.8)	2.00 (50.8) 6.00 (152.4)
SSB 118	0.31 (7.9)	12 - 21/32 (16.7)	14.50 (368.3)	9.00 (228.6)	0.75 (19.1)	3 - 1/2 NPT	26.50 (673.1)	8.25 (209.6)	2.00 (50.8) 6.00 (152.4)
SSB 218	0.31 (7.9)	12 - 21/32 (16.7)	16.25 (412.8)	9.00 (228.6)	0.75 (19.1)	3 - 1/2 NPT	27.00 (685.8)	8.25 (209.6)	2.50 (63.5) 6.50 (165.1)
SSB 318	—	—	19.25 (489)	10.00 (254)	0.75 (19.1)	4 - 1/2 NPT	31.94 (811.3)	8.25 (209.6)	2.50 (63.5) 7.25 (184.2)
SSB 121	0.25 (6.4)	16 - 21/32 (16.7)	23.63 (600.2)	12.00 (304.8)	0.88 (22.4)	4 - 1/2 NPT	38.25 (971.6)	12.75 (323.9)	6.00 (152.4) 9.00 (228.6)
SSB 221	0.25 (6.4)	18 - 25/32 (19.8)	—	—	—	—	—	—	—
SSB 321	0.25 (6.4)	25/32 (19.8)	—	—	—	—	—	—	—
SSB 124H	0.25 (6.4)	18 - 25/32 (19.8)	—	—	—	—	—	—	—
SSB 224H	0.25 (6.4)	11/16 (17.5)	—	—	—	—	—	—	—
SSB 324H	—	—	—	—	—	—	—	—	—
SSB 127	0.25 (6.4)	18 - 25/32 (19.8)	—	—	—	—	—	—	—
SSB 227	0.25 (6.4)	11/16 (17.5)	—	—	—	—	—	—	—
SSB 327	—	—	—	—	—	—	—	—	—
SSB 130H	0.25 (6.4)	18 - 25/32 (19.8)	—	—	—	—	—	—	—
SSB 230H	0.25 (6.4)	11/16 (17.5)	—	—	—	—	—	—	—
SSB 330H	—	—	—	—	—	—	—	—	—
SSB 136H	0.25 (6.4)	18 - 25/32 (19.8)	—	—	—	—	—	—	—
SSB 236H	—	—	—	—	—	—	—	—	—
SSB 336H	—	—	—	—	—	—	—	—	—

Note: For mounting, use socket head capscrews conforming to the ASTM-574-97a.
(Consult factory for drawing before final layout.)

Air Tube Disc Clutches and Brakes

Spring-Set Brakes (Sizes 6, 42-48)

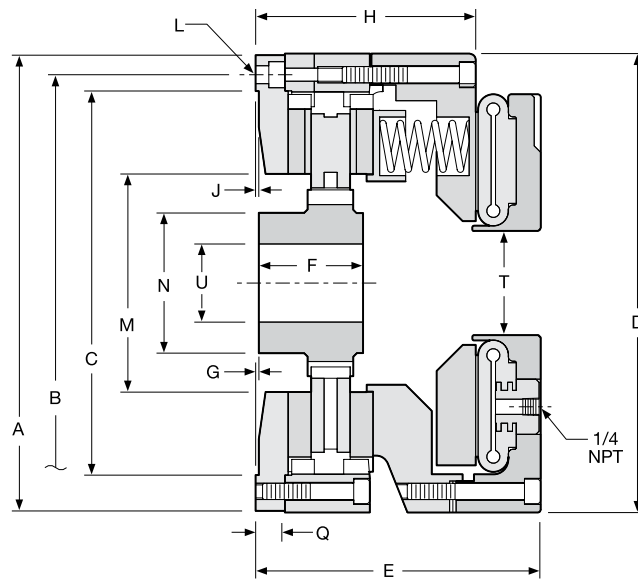

Size 6

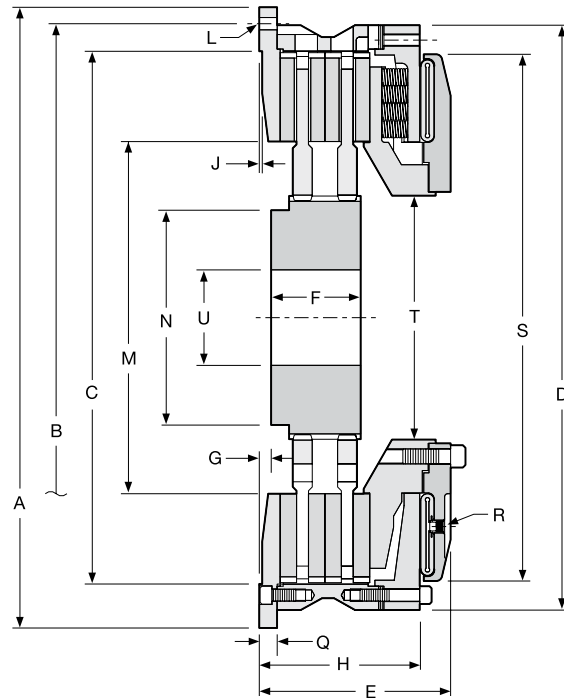

Sizes 42-48

Air Tube Disc Clutches and Brakes

Dimensions: inches (mm)

Model Size ATD-	A	B Hole Circle	C Pilot	D	E	F	G	H
SSB 106	8.75	8.000	7.377 / 7.379	8.81	5.47 (138.9)	2.00 (50.8)	0.00 (0.0)	4.22 (107.2)
SSB 206	(222.3)	(203.20)	(187.38 / 187.43)	(223.8)	6.66 (169.2)	3.25 (82.6)	0.06 (1.5)	5.44 (138.2)
SSB 142	52.00	49.250	44.625 / 44.628	49.00	12.28 (311.9)	5.63 (143.0)	1.00 (25.40)	9.69 (246.1)
SSB 242	(1,320.8)	(1,250.95)	(1,133.48 / 1,133.55)	(1,244.6)	16.03 (407.2)	7.50 (190.5)		13.44 (341.4)
SSB 148	61.00	58.000	52.000 / 52.005	56.75	15.00 (381.0)	6.00 (152.4)	0.00 (0.0)	11.19 (284.2)
SSB 248	(1,549.4)	(1,473.20)	(1,320.80 / 1,320.93)	(1,441.5)	19.33 (491.0)	8.75 (222.3)	1.00 (25.4)	15.5 (393.7)
SSB 260 ¹	70.50	66.500	62.750 / 62.760	70.50	22.31 (566.7)	9.38 (238.3)	0.25 (6.40)	17.61 (447.3)
SSB 360 ¹	(1,790.7)	(1,689.10)	(1,593.85 / 1,594.10)	(1,790.7)	26.88 (682.8)	14.13 (358.9)		22.25 (565.2)

Dimensions: inches (mm)

Model Size ATD-	J	L		M	N	Q	R		S	T	U	
		No. -	Size				No. -	Size			Min.	Max.
SSB 106	0.06	4 -	0.34 (8.6)	4.19	2.69	0.56	2 -	1/4 NPT	—	2.00	0.60	2.00
SSB 206	(1.5)			(106.4)	(68.3)	(14.2)				(50.8)	(15.2)	(50.8)
SSB 142	0.25	24 -	1.06 (26.9)	29.50	18.00	1.50	4 -	1/2 NPT	44.13	20.44	8.00	14.00
SSB 242	(6.4)			(749.3)	(457.2)	(26.9)			(1,102.9)	(519.2)	(203.2)	(355.6)
SSB 148	0.25	24 -	1.06 (26.9)	32.00	25.75	1.50	4 -	1/2 NPT	52.13	19.00	10.00	18.00
SSB 248	(6.4)			(812.8)	(654.1)	(38.1)			(1,324.1)	(482.6)	(254.0)	(457.2)
SSB 260 ¹	0.25	24 -	4.5" NC	36.00	27.00	—	6 -	1/2 NPT	61.50	20.63	11.00	19.00
SSB 360 ¹	(6.4)			(914.4)	(685.8)				(1,562.1)	(524.0)	(279.4)	(482.6)

¹ Less backplate.

NOTE: For mounting, use socket head capscrews conforming to the ASTM-574-97a.
(Consult factory for drawing before final layout.)