

HC Oil Immersed Clutches

Model HC Oil Immersed

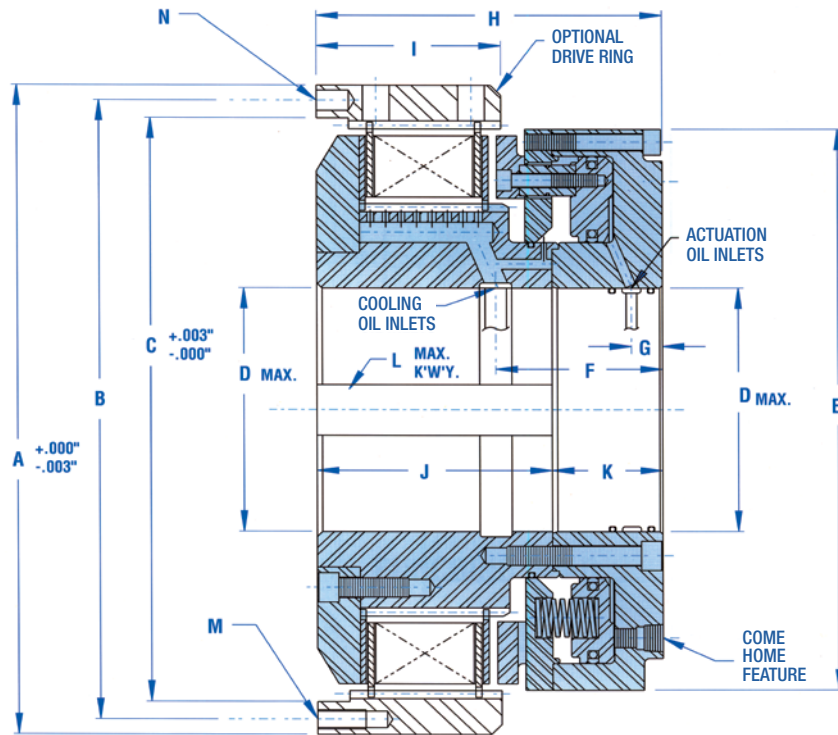

Dimensions (mm)

Clutch Model	A	B	C	D	E	F	G	H	I	J	K	L	M	N
HC-8-6	257	239.7	222	76	211	78	13	150	68.1	96.8	54.1	19	(12) - M10	(4) - 10
HC-8-8	257	239.7	222	76	211	78	13	166	83.3	111.8	54.1	19	(12) - M10	(4) - 10
HC-8-10	257	239.7	222	76	211	78	13	181	98.6	127	54.1	19	(12) - M10	(4) - 10
HC-10-6	298	281	264	102	249	81	14	157	75.4	107	49.3	25	(12) - M10	(4) - 12
HC-10-8	298	281	264	102	249	81	14	173	91.7	124	49.3	25	(12) - M10	(4) - 12
HC-10-10	298	281	264	102	249	81	14	189	108	140.2	49.3	25	(12) - M10	(4) - 12
HC-13-6	406	387.4	365	152	351	99	18	186	90	121.2	65	32	(12) - M12	(4) - 12
HC-13-8	406	387.4	365	152	351	99	18	204	109.2	139.2	65	32	(12) - M12	(4) - 12
HC-13-10	406	387.4	365	152	351	99	18	223	127.5	57.5	65	32	(12) - M12	(4) - 12
HC-15-6	467	441.3	416	165	400	95	20	213	111	145.8	66.8	38	(12) - M16	(4) - 16
HC-15-8	467	441.3	416	165	400	95	20	236	134.9	169.7	66.8	38	(12) - M16	(4) - 16
HC-15-10	467	441.3	416	165	400	95	20	260	158.8	193.8	66.8	38	(12) - M16	(4) - 16
HC-16-6	508	482.6	457	191	438	113	35	219	111	146.1	72.9	38	(12) - M16	(4) - 16
HC-16-8	508	482.6	457	191	438	113	35	243	134.9	169.9	72.9	38	(12) - M16	(4) - 16
HC-16-10	508	482.6	457	191	438	113	35	267	158.8	193.8	72.9	38	(12) - M16	(4) - 16
HC-18-6	559	527.1	495	203	473	122	38	259	147.8	181.1	77.7	38	(12) - M20	(4) - 20
HC-18-8	559	527.1	495	203	473	122	38	291	180.3	213.6	77.7	38	(12) - M20	(4) - 20
HC-18-10	559	527.1	495	203	473	122	38	324	212.9	246.1	77.7	38	(12) - M20	(4) - 20
HC-20-6	635	603.3	572	229	524	146	44	287	157.2	194.6	91.9	38	(12) - M20	(4) - 20
HC-20-8	635	603.3	572	229	524	146	44	319	189.7	227.1	91.9	38	(12) - M20	(4) - 20
HC-20-10	635	603.3	572	229	524	146	44	352	222.3	259.6	91.9	38	(12) - M20	(4) - 20

NOTES

- Use DXF certified drawing dimensions only for final layouts.
- DXF and IGES files available upon request.
- Dimensions subject to change without notice.
- All threaded fasteners are metric.

Model HC/HCD Clutch Description

The Model HC or HCD clutches are designed to be used in either an end of shaft or through shaft mounting configuration. Their compact size makes these units ideal for incorporating within a gear housing. Multiple speed transmissions use a variety of these units to effect fixed mesh speed changes, or they may be used as a stand alone device for disconnect service.

The Model HCD clutches are provided with an internally splined outer drive ring for bolting to the user's driving or driven member. The Model HC clutches are provided without this drive ring to allow the user to spline the inside diameter of their driving or driven member which conserves radial space and provides for design compactness. All units incorporate provisions for forced oil cooling allowing high energy engagements to be made without causing thermal distress within the disc pack. Cooling oil is introduced from an external supply through axial holes provided in the shaft. Actuation pressure may come from either a pneumatic or hydraulic source. This pressure may be introduced through an axial hole provided at the shaft centre, or in the case of end shaft mounts, it may be introduced through a separate manifold.

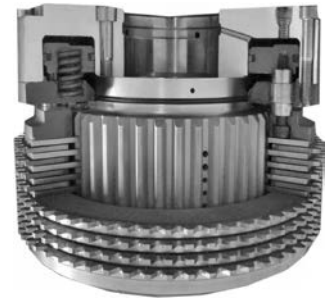

All torque transmitting members are designed for continuous heavy duty industrial service. Hubs and drive rings are fully hardened and manufactured from high quality alloy steel forgings. Disc pack cores are designed using extra-heavy plate thicknesses to maximize torque and heat capacity. Friction materials and grooving patterns are designed to provide for high thermal and smooth engagement performance. All of the Model HC and HCD clutches contain friction materials which allow for controlled slip operation in those applications requiring this feature.

Marine main propulsion forward/reverse or disconnect service, winch disconnects, conveyor or mill soft-starts, and multi-speed transmissions are but a few of the applications for the model HC/HCD oil immersed clutches.

Operational Data

Clutch Model	Static Torque (Nm)	Dynamic Torque (Nm)	Actuator Volume (cm ³)	Weight Outer (kg)	Weight Inner (kg)	WR2 Outer (kgm ³)	WR2 Inner (kgm ³)	Maximum RPM
HC-8-6	6200	4400	72	3	27	0.023	0.160	2600
HC-8-8	8000	5600	72	3	30	0.030	0.170	2600
HC-8-10	9500	6800	72	4	32	0.038	0.181	2600
HC-10-6	8500	6000	120	4	38	0.043	0.316	2200
HC-10-8	11000	8000	120	5	41	0.058	0.340	2200
HC-10-10	14000	10000	120	6	44	0.072	0.362	2200
HC-13-6	22500	16000	229	7	89	0.181	1.513	1700
HC-13-8	31000	22000	229	10	96	0.224	1.618	1700
HC-13-10	40000	28000	229	12	103	0.304	1.719	1700
HC-15-6	36000	26000	311	15	132	0.464	2.823	1450
HC-15-8	48000	34000	311	20	143	0.632	3.034	1450
HC-15-10	60000	42000	311	26	155	0.801	3.245	1450
HC-16-6	50000	36000	393	18	162	0.674	4.340	1300
HC-16-8	67500	48000	393	24	176	0.927	4.635	1300
HC-16-10	85000	60000	393	30	189	1.138	4.973	1300
HC-18-6	65000	46000	508	29	224	1.264	6.911	1200
HC-18-8	80000	56000	508	38	247	1.686	7.543	1200
HC-18-10	105000	76000	508	48	269	2.107	8.175	1200
HC-20-6	85000	62000	836	43	304	2.444	11.757	1100
HC-20-8	115000	82000	836	58	331	3.287	12.642	1100
HC-20-10	144000	103000	836	72	357	4.088	13.527	1100

NOTES

- Operating pressure 24 BAR
- Torque capacities can be modified. Consult Engineering.
- Consult factory for service factors required per application.
- Consult factory for oil flow requirements per application and shaft oil hole diameters.

HC (Dry) Clutches

Model HC (Dry)

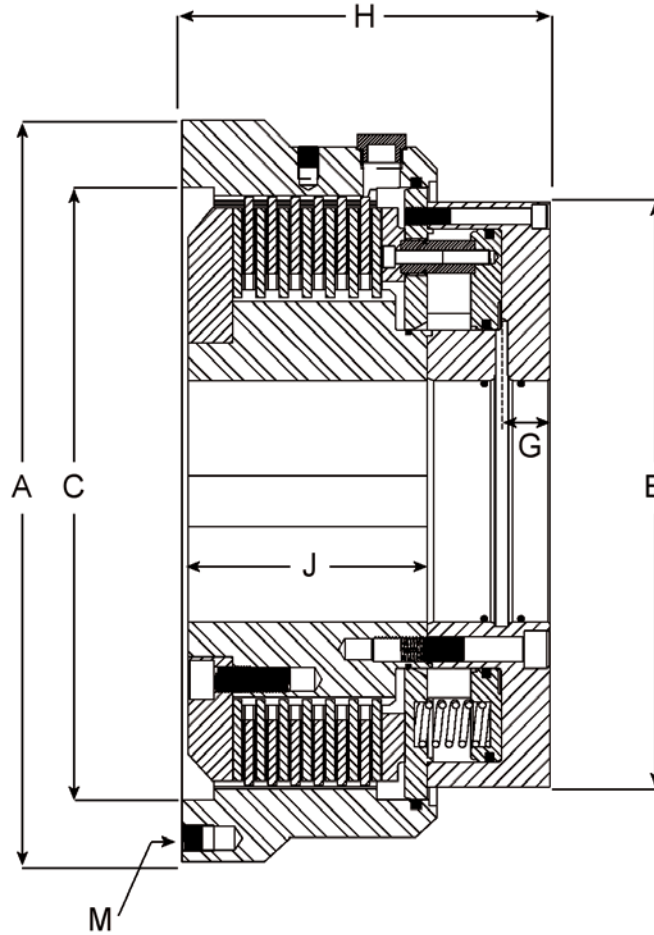

Dimensions (mm):

Clutch Model	A	B	C	D	E	F	G	H	I	J	K	L	M
HC-8-6	257	-	222	-	211	-	13	150	-	108	-	-	12 x M10
HC-10-6	298	-	264	-	249	-	14.2	166	-	117	-	-	12 x M10
HC-13-6	430	-	365	-	351	-	18.3	213	-	129	-	-	24 x M20
HC-15-6	400	-	416	-	400	-	19.8	234	-	154	-	-	30 x M20
HC-18-6	600	-	495	-	473	-	38	290	-	188	-	-	36 x M20
HC-20-6	660	-	546	-	524	-	44.4	312	-	201	-	-	36 x M24

Model HC (Dry)

The Model HC (Dry Lining) clutches are designed to be used in either an end of shaft or through shaft mounting configuration. The use of 24 bar hydraulic actuation and multiple dry organic lined friction plates provides a clutch range with very high torque capability relative to overall diameter. The end result is a clutch that is compact dimensionally, whilst providing high torque solutions in the smallest envelope space.



The Model HC(D) clutches are provided with an internally splined outer drive ring for bolting to the users driving or driven member. The clutch can also be supplied without an external drive ring to allow for customers to incorporate the external drive spline within a component of their own manufacture. This possibility enables designs where minimal axial space is desirable, by allowing the clutch to fit within the customers driving or driven component.

Actuation pressure may come from either a pneumatic or hydraulic source. This pressure may be introduced through an axial hole provided at the shaft centreline, or, in the case of end shaft mounts, it may be introduced through a separate manifold.

All torque transmitting members are designed to provide for continuous heavy duty industrial service. Hubs and drive rings are fully hardened and manufactured from high quality alloy steel forgings. Disc pack cores are designed using extra-heavy plate thicknesses to maximise torque and heat capacity.

Friction materials designed to provide for high thermal load acceptance and smooth engagement performance.

The clutch range is designed for use in harsh external environments benefitting from a completely enclosed design and incorporating a dust / water ingress seal between the rotating components this makes it ideal for applications open to the elements. Optional 2 pack epoxy paint finishes provide additional protection and can be specified if required.

Winch connect / disconnect drives, conveyor or mill drives and multi-speed transmissions are but a few of the applications for the model HC/HCD dry lined clutch range.

Operational Data:

Clutch Model	Static Torque (Nm)	Dynamic Torque (Nm)	Actuator Volume (cm ³)	Weight Outer (kg)	Weight Inner (kg)	MR2 Outer (kgm ³)	MR2 Inner (kgm ³)	Maximum RPM
HC-8-6	15525	18628	71.6	2.63	27.48	0.079	0.159	2600
HC-10-6	20550	24468	119.6	3.53	37.9	0.043	0.316	2200
HC-13-6	56110	66045	229.41	7.39	88.7	0.168	1.512	1700
HC-15-6	90205	106126	311.35	15.42	131.99	0.463	2.823	1450
HC-18-6	155802	178945	507.99	28.57	224.07	1.264	6.911	1200
HC-20-6	278410	320626	835.74	35.83	298.46	1.938	11.378	1100