

Size 15 thru 29 Mesur-Fil® Fluid Couplings

Installation Instructions

P-1033-2



An Altra Industrial Motion Company

Installation Instructions

Sizes 15-29 for HC, HCF, HCR and HSD Models

These models are similar in their assembly procedures, but the following steps must be observed for the HCF, HCR and HSD types before proceeding:

HCF & HCR - Remove the flexible coupling "half," which is located on the output of the unit.

HSD - Lubricate the tapers on both the sheave inside diameter and the units sheave hub outside diameter. Bolt the sheave to the coupling and tighten the bolts to 40-44 lb. ft.

Proceed as follows:

- 1) Drill and tap the motor shaft axially to the specification indicated in Table A, Figure 1. This hole must be reasonably straight and concentric.
- 2) Clean the motor shaft and coupling bore. Lubricate with an anti-seizing grease. Insert a threaded rod per the specifications in Table A into the motor shaft tapped hole.
- 3) Insert the key in the motor shaft keyway. Slip the coupling over the threaded rod and onto the motor shaft, taking care to align the keyways with the key.

- 4) Place a washer (preferably of brass or heavy nylon) over the threaded rod and slide it up to the coupling. This washer is to protect the coupling from damage during installation, and should be sized so that it engages the bearing carrier without slipping inside where it may damage the seal.
- 5) Thread an appropriate nut onto the threaded rod and tighten the nut against the washer until the coupling is fully seated on the shaft.
- 6) Remove the threaded rod, insert the axial retaining bolt in the hole from which the rod was removed and tighten the retaining bolt into the motor shaft to lock the unit on the shaft.

When installing an HCF, position the motor to establish a gap of 1/8" between the coupling halves when the coupling is attached to the driven equipment. See Figure 2. Other mounting information is listed in Table B.

The tools and hardware required for mounting are available in kit form. Contact your Wichita sales representative for more information.

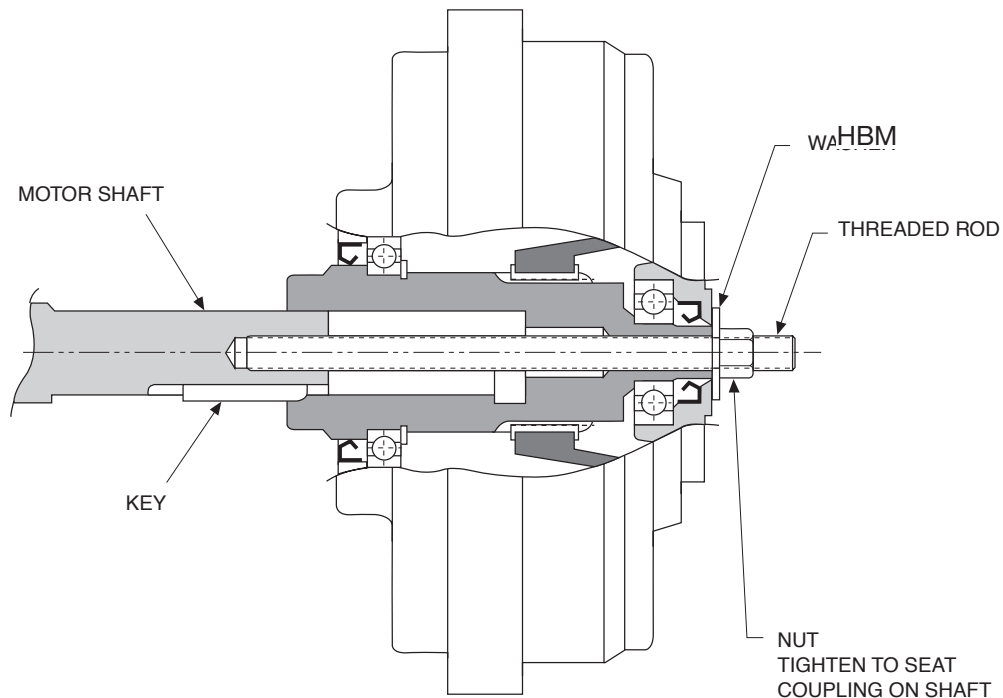

(Figure 1)

Table A

Coupling Size	Tap Motor Shaft	Threaded Rod	Washer	Hex Nut
15	3/4-10 1" Deep	3/4-10 10" Long	3/4" I.D.	3/4-10
17-24	7/8-9 1" Deep	7/8-9 14" Long	7/8" I.D.	7/8-9
27, 29	1-8 1.5" Deep	1-8 17" Long	1" I.D.	1-8

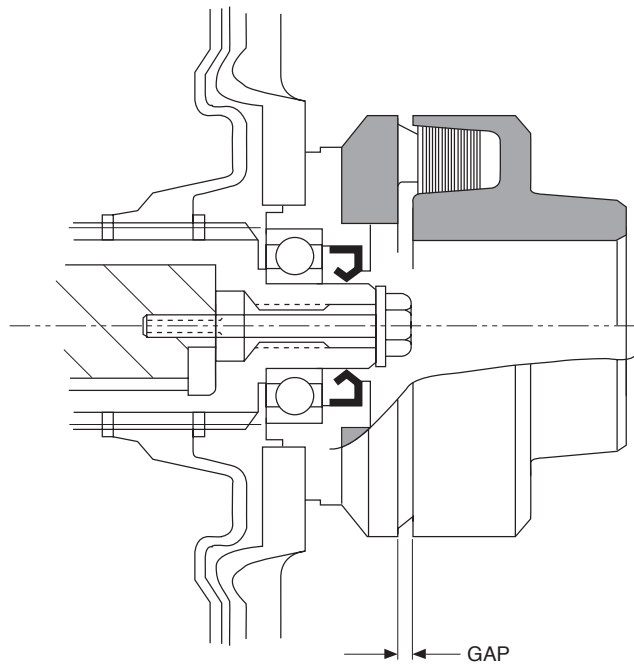

(Figure 2)

Table B

HCF	BT	GAP	<*	≠*
15	40	.118	45'	.015"
17-19	50	.118	35'	.020"
21-24	60	.118	35'	.024"
27-29	80	.157	15'	.024"

* For speeds over 1800 RPM reduce values by 50 percent.

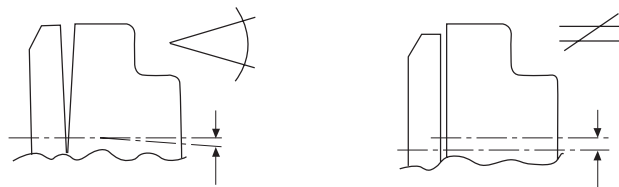

Size 15-29 for HCM Models

This unit is to be installed between two halves of a double engagement gear-tooth flexible coupling that must be provided by the user. Coupling size is listed for each Mesur-Fil size in the specification page of the catalog. Install as follows:

- 1) Assemble the flexible coupling onto the application shafts.
- 2) Align shafts within .005" TIR.
- 3) Install fluid coupling. Use capscrews and other hardware supplied with the fluid coupling to assemble the flex coupling sleeve to the input flange. Use the hardware supplied with the flexible coupling to connect the output side.
- 4) Lubricate the flexible coupling according to the manufacturer's instructions.

Filling Instructions

To fill the fluid coupling, or to make any change in the quantity of oil, the unit must be held or mounted with the shaft horizontal. Failure to do this will result in improper filling which may lead to damage to the coupling or other equipment.

- 1) Select the proper fill number (see Engineering and Selection Manual, or contact your Dana representative). Orient the coupling, with the shaft horizontal, so that the number on the casting corresponding to the selected fill is at the top, or 12 o'clock, position. See Figure 3. Use fill No. 2 for delayed fill couplings.
- 2) Remove the filler plug(s) from the coupling. The coupling is at the specified fill when the oil is level with the filler holes. To change the fill level, put the appropriate number in the 12 o'clock position and add or remove oil until it is level with the filler holes.

For vertical applications, or applications where performing the above procedure may be difficult, the fill must be measured. These fill measures are listed in Table C.

Recommended Oil: SAE 10 W

Agip:	OSO 32
Aral:	HT 4
BP:	ENERGOL HLP 32
Castrol:	HYSPIN AWS 32
Chevron:	HYDRAULIC OIL EP 32
Esso:	TERESSO 32 O NUTO H32
Mobil:	DTE OIL LIGHT (MEDIUM)
Shell:	TELLUS 32
Texaco:	RANDO HDA 32
Total:	AZOLLA 32

Fusible Plug

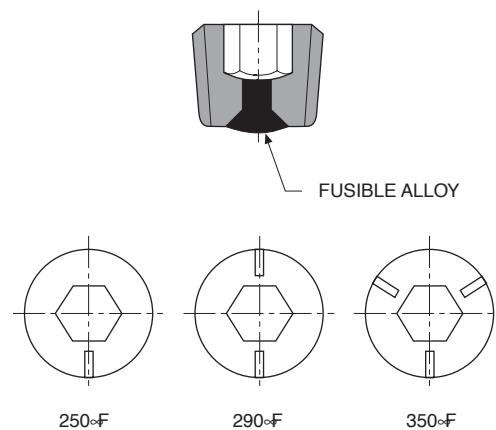

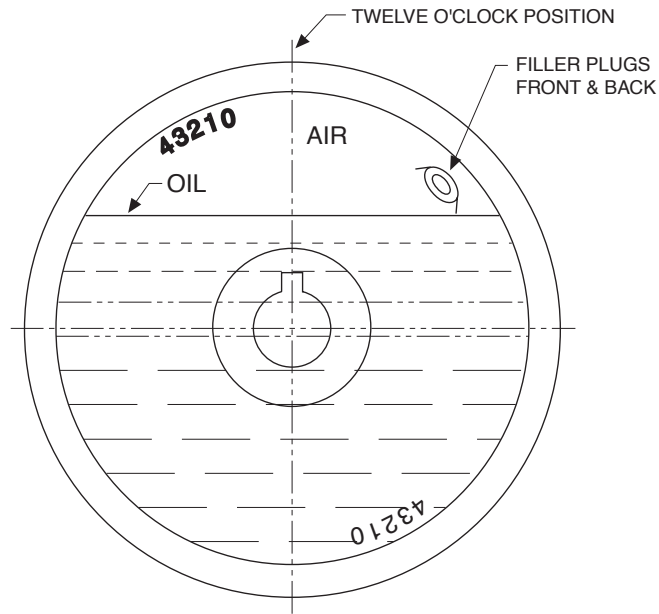

(Figure 3)

Table C

Size	Quarts 0 or X	Oil Quantities for Fill Number				Delayed Fill
		1	2	3	4	
15	8.0	7.6	7.0	6.3	5.7	9.1
17	12.4	11.5	10.6	9.6	8.7	14.0
19	15	14	13	11.8	10.6	17.4
21	20	18.8	17.3	15.8	14.3	24.3
24	30	28	26	23.9	21.7	33
27	47	43.3	40.2	36.5	32.8	53
29	52	48.4	44.7	40.7	36.5	67

Disassembly

HC, HCF, HSD Models

Note: HCF model flexible coupling halves must be removed before proceeding.

- 1) Remove the axial retaining bolt from the end of the unit.
- 2) Insert a bolt (see Table D for size) into the tapped hole Q in the end of the fluid coupling shaft in the center of the bearing carrier. See Figure 4. Screw the bolt in to push the coupling off the motor shaft.

HCM Models

Disassembly is the reverse of assembly: Remove the bolts from the output and input flanges of the coupling, then lift the unit clear.

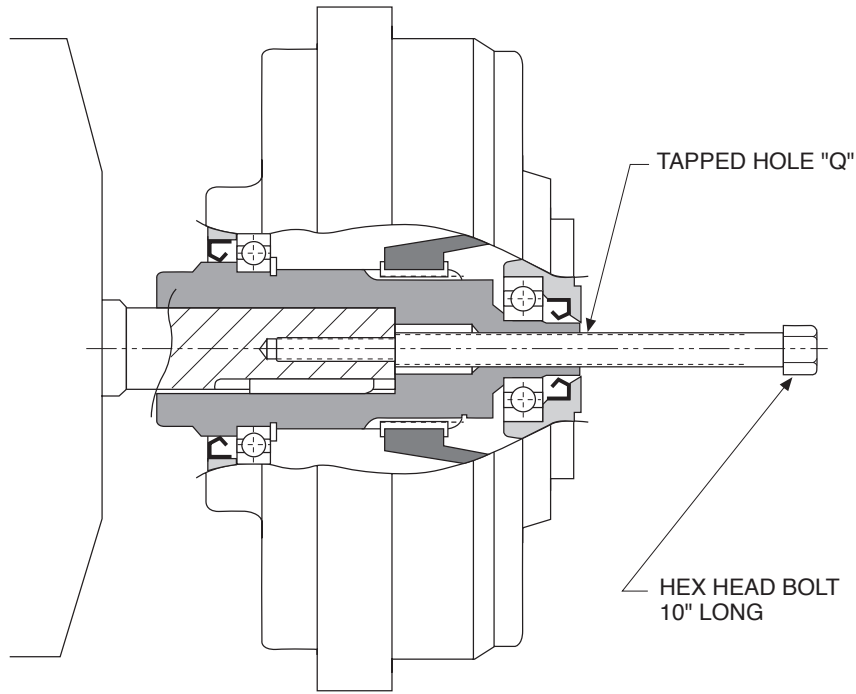

(Figure 4)

Table D

Unit Size	Thread Size "Q"
15	7/8 - 9
17-24	1 1/4 - 7
27, 29	1 3/4 - 5

Operation and Maintenance

1) Start motor several times to check coupling performance. Maximum housing temperature should not exceed 200°F.

High operating temperature can be caused by one or more of the following:

- a) Low oil level
- b) Load too great for motor
- c) Ambient temperature too high
- d) Starting or cycling too frequently
- e) Starting time too long
- f) Inadequate ventilation
- g) Coupling improperly applied

2) After the first twenty days, check the oil level. This must be performed cold. At this time, check the retaining screw and all mounting bolts. These operations should be repeated every six months.

3) Check tightness of all hardware. HCF units: check alignment of the flexible coupling. If the "backlash" in the flexible coupling exceeds two degrees, the rubber element should be replaced.

4) Oil should be replaced after 4000 hours of operation.

Spare Parts

Recommended Spare Parts

- Seal KitItems 4, 5, 6, 15 & 20
- Bearing KitItems 16 & 21
- Fusible PlugItem 13
- Rubber Elements for HCF TypeItem 28

Note: When ordering spare parts, specify size and model type along with specification number marked on side of coupling. See Figure 5.

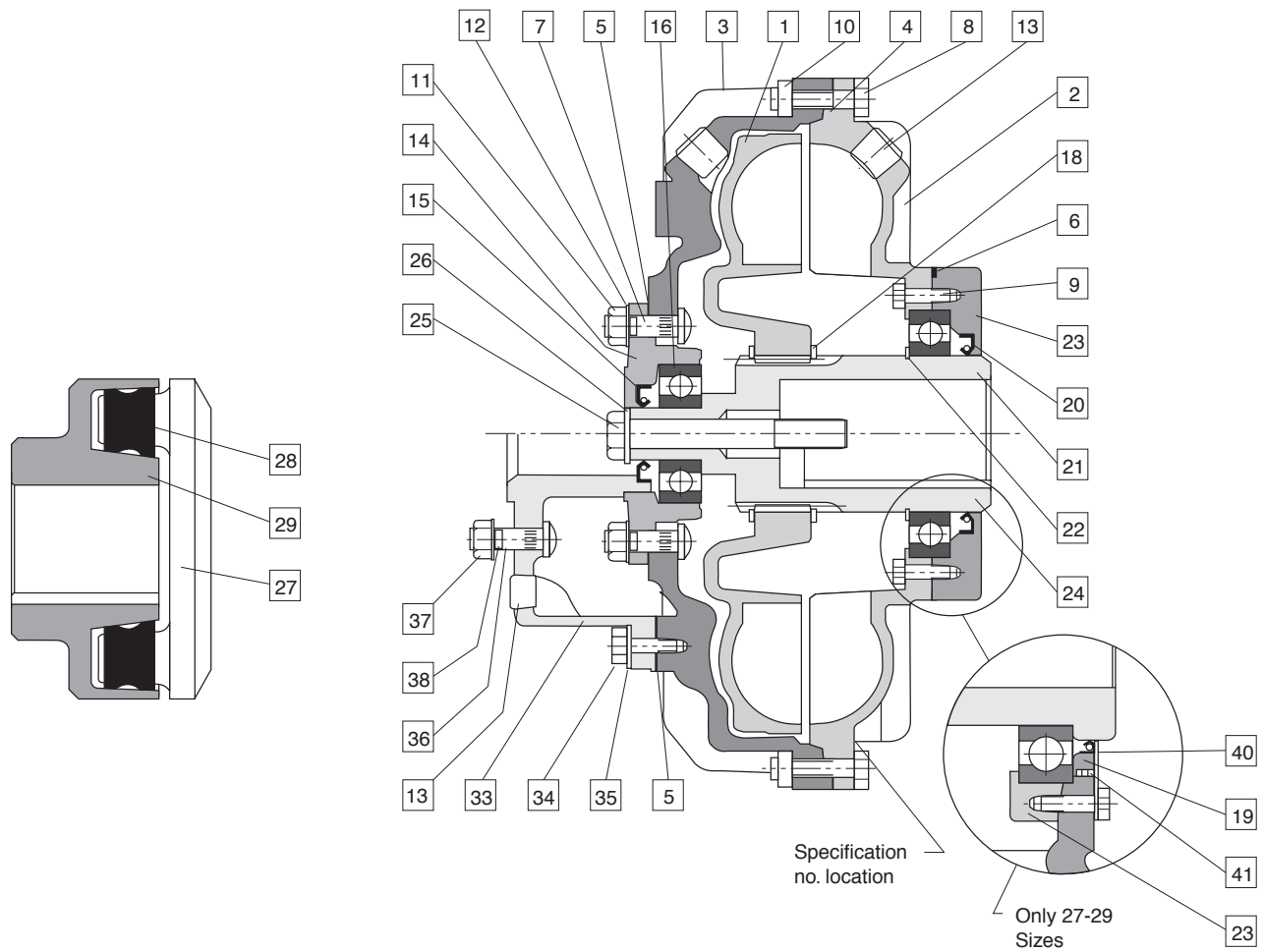

(Figure 5)

- | | | | |
|----|-----------------|----|-----------------|
| 1 | Runner | 21 | Ball Bearing |
| 2 | Impeller | 22 | Snap Ring |
| 3 | Cover | 23 | Bearing Carrier |
| 4 | O Ring | 24 | Shaft |
| 5 | Gasket | 25 | Retaining Bolt |
| 6 | Gasket | 26 | Washer |
| 7 | Bolt | 27 | Flange |
| 8 | Bolt | 28 | Rubber Block |
| 9 | Bolt | 29 | Coupling Half |
| 10 | Nut | 33 | D.F. Chamber |
| 11 | Nut | 34 | Bolt |
| 12 | Lock Washer | 35 | Lock Washer |
| 13 | *Plug | 36 | Bolt |
| 14 | Bearing Carrier | 37 | Nut |
| 15 | Seal | 38 | Lock Washer |
| 16 | Ball Bearing | 40 | Plate |
| 18 | Snap Ring | 41 | O Ring |
| 20 | Seal | | |

* Fusible plug is supplied in replacement of standard plug (item 13) fitted on outer housing item 2.

Warranty

Wichita/Warner Electric warrants that it will repair or replace (whichever it deems advisable) any product manufactured and sold by it which proves to be defective in material or workmanship within a period of one (1) year from date of original purchase for consumer, commercial or industrial use. This warranty extends only to the original purchaser and is not transferable or assignable without Wichita/Warner Electric's prior consent. This warranty covers normal use and does not cover damage or defect which results from alteration, accident, neglect, or improper installation, operation, or maintenance. Wichita/Warner Electric's obligation under this warranty is limited to the repair or replacement of the defective product and in no event shall Wichita/Warner Electric be liable for consequential, indirect or incidental damages of any kind incurred by reasons of manufacture, sale or use of any defective product. Wichita/Warner Electric neither assumes nor authorizes any other person to give any other warranty or to assume any other obligation or liability on its behalf.



Wichita Clutch
2800 Fisher Road, Wichita Falls, TX 76032 - USA
800-964-3262 • Fax: 940-723-3436
www.wichitaclutch.com