

# Size 7.0 Mesur-Fil<sup>®</sup> Fluid Couplings

## Installation Instructions

P-1033  
WC-96



 **Wichita<sup>®</sup>**  
Clutch

An Altra Industrial Motion Company

**Size 7.0 Fluid Couplings  
Models HC, HCF, HCM, HBM**

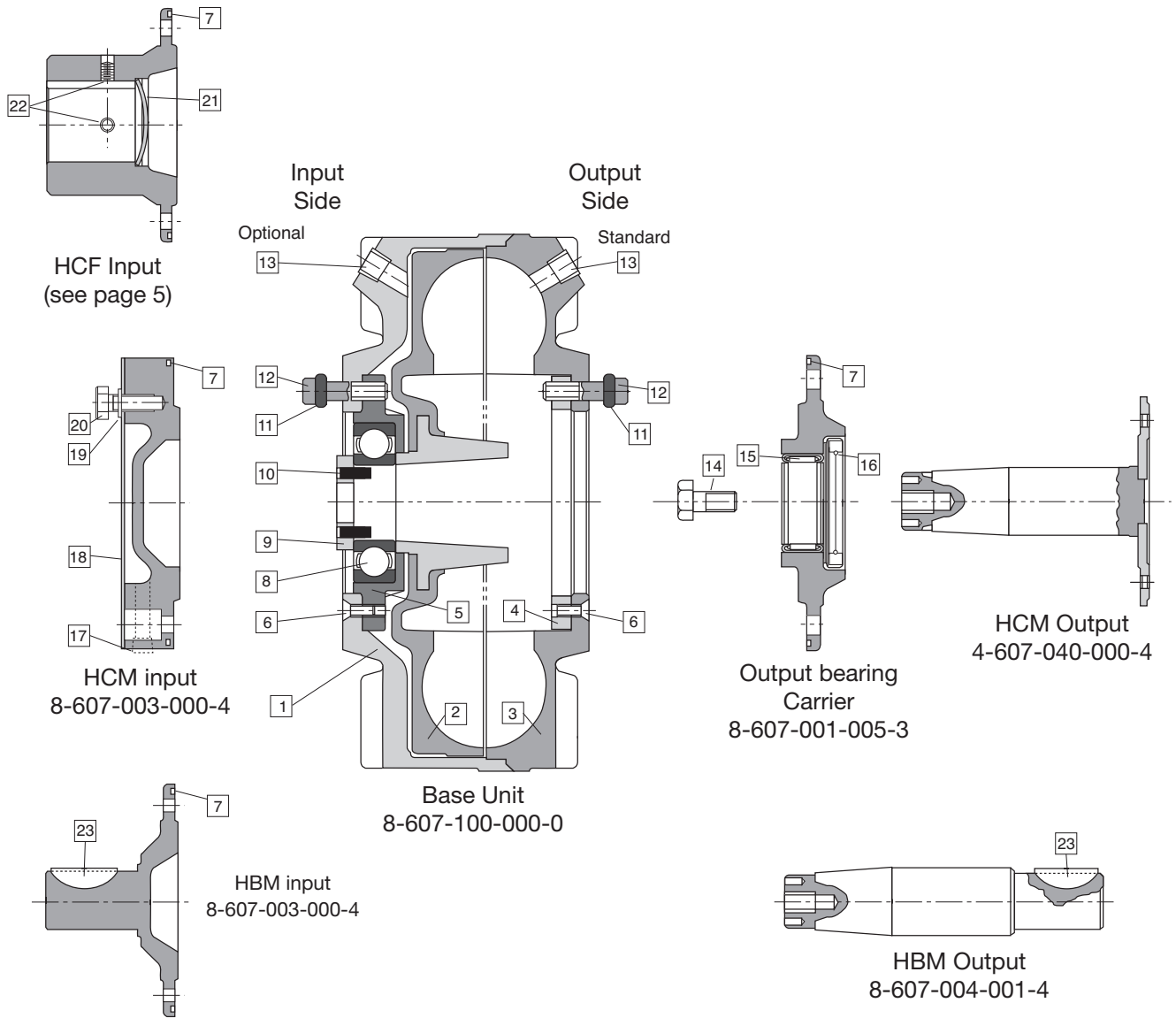

Item	Description	Qty.	Part Number
1	Front Cover	1	Items 1-6 are
2	Runner	1	components of
3	Impeller	1	subassembly
4	Retaining Ring	1	8-607-001-000-0
5	Input Bearing Carrier	1	
6	Flathead Capscrew	4	
7	O-Ring	2	2-756-037-000-3
8	Ball Bearing	1	2-701-009-000-1
9	Retaining Washer	1	4-607-026-000-4
10	Roll Pin	2	2-105-012-050-2
11	O-Ring	12	2-756-002-000-1
12	12 Point Screw	12	2-197-025-007-0

Item	Description	Qty.	Part Number
13	Fill Plug	2	2-221-003-420-1
14	Retaining Bolt	1	2-173-037-012-0
15	Needle Bearing	1	2-721-012-000-1
16	Oil Seal	1	2-730-012-001-1
17	Grease Plug	1	2-221-001-424-1
18	Gasket	1	4-607-018-000-9
19	Lock Washer	6	2-135-025-111-0
20	Hex Head Capscrew	6	2-172-025-012-0
21	Expansion Plug	1	4-607-070-018-3
22	Set Screw	2	2-192-031-003-0
23	Woodruff Key	1	2-120-008-024-0

## Assembly Instructions

**Note:** Tapers to be cleaned with suitable solvent, wiped dry prior to assembly. Do not use molybdenum disulfide or equivalent friction reducing compounds on fasteners or taper.

1. If seal and needle bearing are not in place in rear bearing carrier, install them.
2. Install "O" ring in rear bearing carrier. Mount rear bearing carrier and "O" ring to coupling face using the six 12 point capscrews with "O" rings. Tighten capscrews to 11-13 lb.ft. torque.
3. Install ball bearing into front bearing carrier. Care must be taken not to damage front cover adjacent to flat head screws.
4. Install output shaft or output flange assembly through rear bearing carrier and into taper in runner hub. Support the output end of output shaft or output flange assembly and press ball bearing onto output shaft until bearing inner race overhangs shaft end .060 to .120".

**▲CAUTION** Do not press flush with shaft end. Press force never to exceed 8,500 lbs. Install roll pins in retainer washer. Install retainer washer with roll pins and capscrew and tighten to 38-42 lb.ft. torque. Bearing and runner are now in place.

**Note:** Hold shaft from turning while tightening capscrew, with open end or pipe wrench on retainer washer.

5. Mount selected input group with "O" ring and six 12 point capscrews with "O" rings to input end. Tighten 11-13 lb.ft. torque.
6. Check air tightness with 5-10 psi pressure applied thru one fill hole.

## Service Disassembly Instructions

1. Remove the two pipe plugs in the front cover and impeller, and allow fluid to drain completely.
2. Remove coupling assembly from installation.
3. Remove the six 12 point capscrews and "O" rings from the input group. Remove input group and "O" ring.
4. Remove hex head capscrew which retains the output shaft or output flange assembly. Remove the retaining washer.
5. To remove models HC or HCF output shaft and model HCM output flange assembly, pack shaft center screw hole with grease. Wrap thread of removed hex head capscrew with several layers of teflon tape to seal against high grease pressure. Insert screw thru retainer washer into grease filled hole and tighten. Repack hole if necessary until release of taper joint is achieved. To remove model HBM output shaft, first remove output bearing carrier per instruction No. 6. Support runner on a tube\* and press output shaft from runner. Use plug against output shaft to protect threads in shaft.
6. Remove six 12 point capscrews and "O" rings from output bearing carrier. Remove carrier assembly and "O" ring.
7. If removal of bearing and seal from output bearing carrier is necessary, press out from coupling side.
8. To remove input ball bearing use a rod and tap out from coupling output end.

**Note:** If the front cover and impeller assembly is damaged, the basic unit must be replaced.

### \*Tools required for disassembly

1. Teflon tape
2. Tube (2.00 O.D. x 1.31 I.D. x 4.00 long)

### Recommended replacement for overhaul

1. Seal
2. Bearings
3. All "O" rings

Repair Kit Number:

8-607-001-003-2 - Major Repair Kit  
Includes 1, 2, & 3

8-607-001-002-2 - Minor Repair Kit  
Includes 1 & 3 only

**Size 7.0 Fluid Couplings  
Model HC**

**Assembly No. 6-607-001-002-0000**

Input - customer supplied/Output - customer supplied

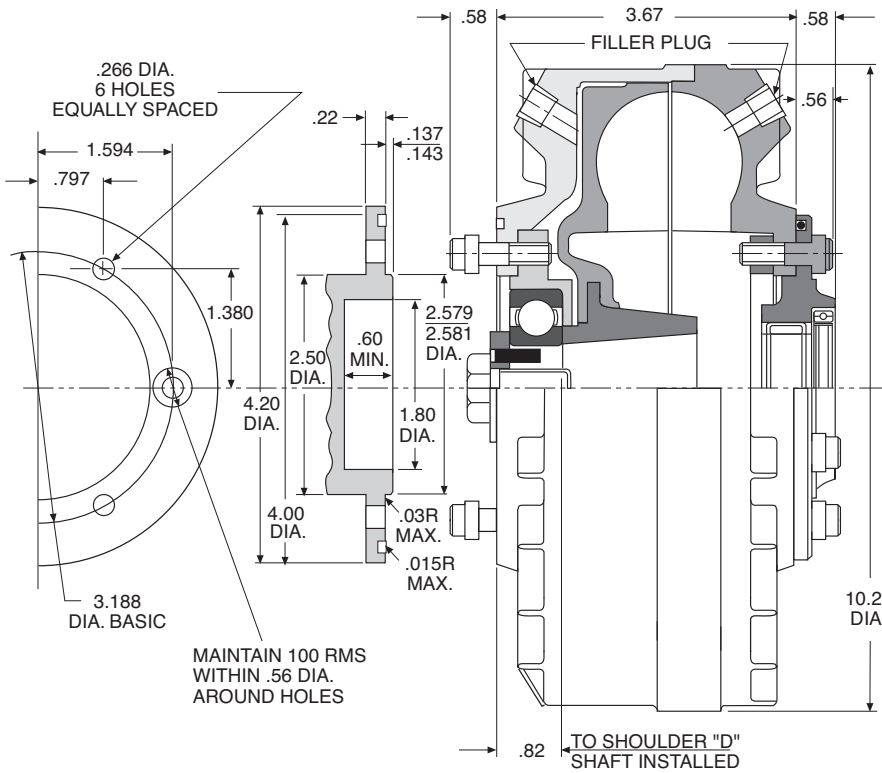

Customer supplied

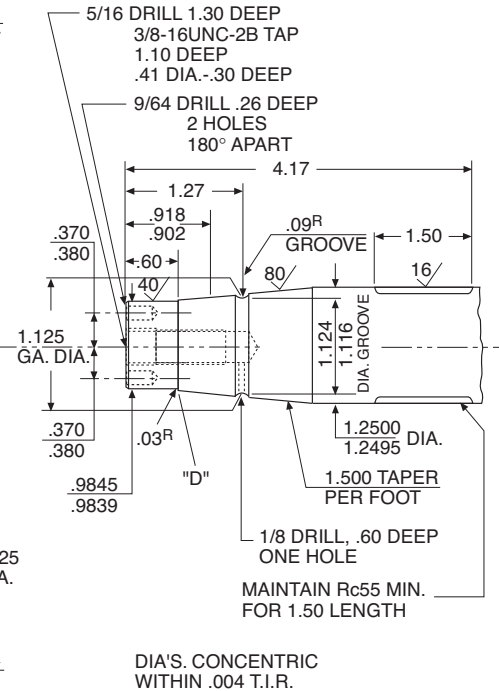

Customer supplied

**Installation Procedure**

This basic coupling must be completed by customer. Input flange and output shaft to be made per dimensions shown.

## Model HCF

**Assembly No. See chart below**

Input - see chart below/Output - customer supplied

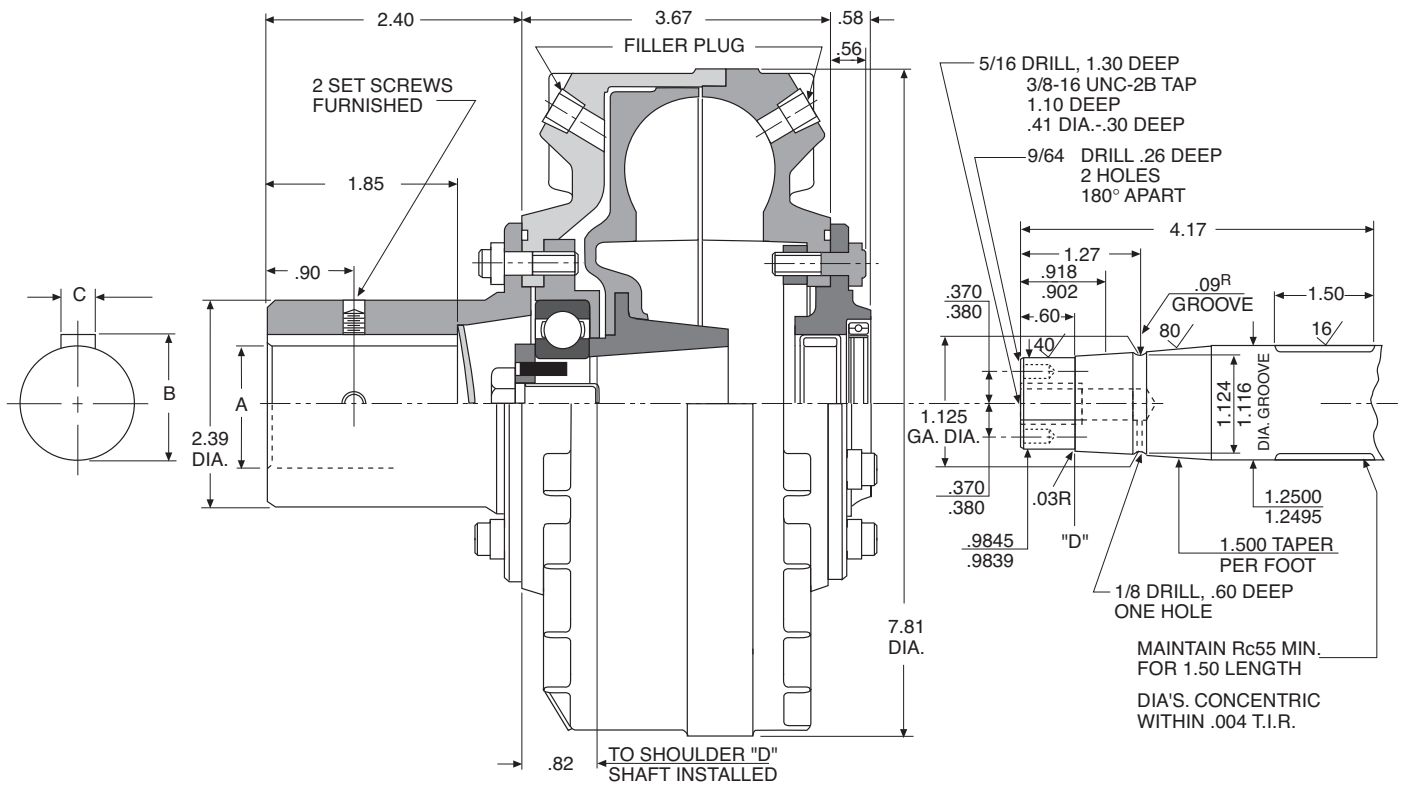

Customer supplied

Assembly No.	HFC Input Group	Bore A	B	KWY.C
6-607-002-000-0000	8-607-002-000-4	.874 - .875	.959 - .974	.1865 - .1885
6-607-002-003-0000	8-607-002-003-4	.999 - 1.000	1.109 - 1.124	.249 - .251
6-607-002-001-0000	8-607-002-001-4	1.124 - 1.125	1.235 - 1.250	.249 - .251
6-607-002-002-0000	8-607-002-002-4	1.374 - 1.375	1.512 - 1.527	.3115 - .3135

## Installation Procedure

This coupling must be completed by customer.  
Output shaft to be made per dimensions shown.

## Model HCM

### Assembly No. 6-607-003-000-0000

Input 8-607-003-000-4/Output 4-607-040-000-4

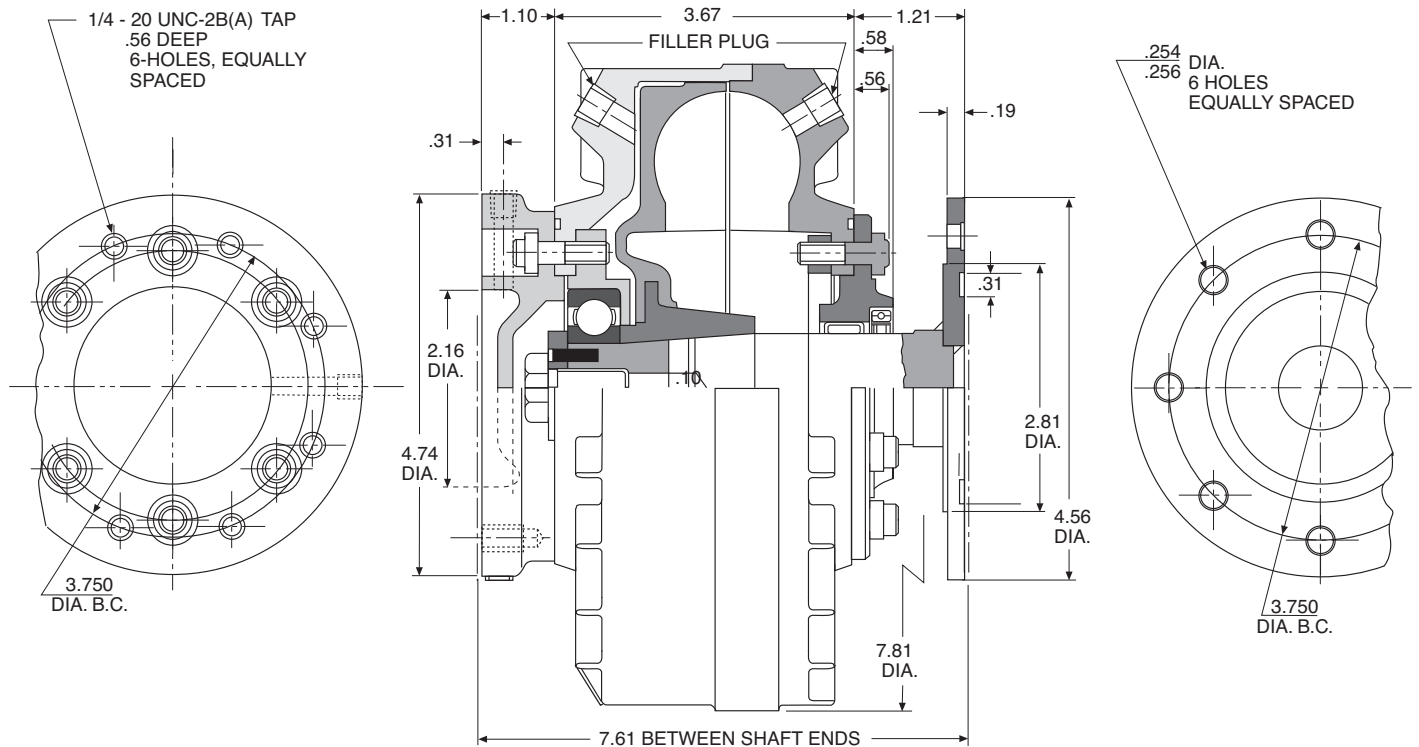

## Installation Procedure

This coupling is a complete unit and is to be installed between two halves of a double engagement gear-tooth flexible coupling provided by user. Install in the following sequence:

1. Assemble flexible coupling to shafts.
2. Align shafts within .005 total indicator reading.
3. Install fluid coupling.

**Note:** Use capscrews (2-172-025-012-0). Lock washers (2-135-025-111-0) and gasket (4-607-018-000-9). Assemble flexible coupling sleeve to input flange. Bolts, nuts and gasket furnished with flexible couplings to be used at flanged shaft end of fluid coupling.

4. Lubricate flexible coupling per manufacturer's instructions.

Recommended flexible couplings:

Manufacturer	Model	Max. Shaft Size
Poole	MXB 1x1.8	1.625
Waldron	1W	1.625

## Model HBM

### Assembly No. 6-607-004-000-0000

Input 8-607-004-000-4 Group/Output 8-607-004-001-4 Group

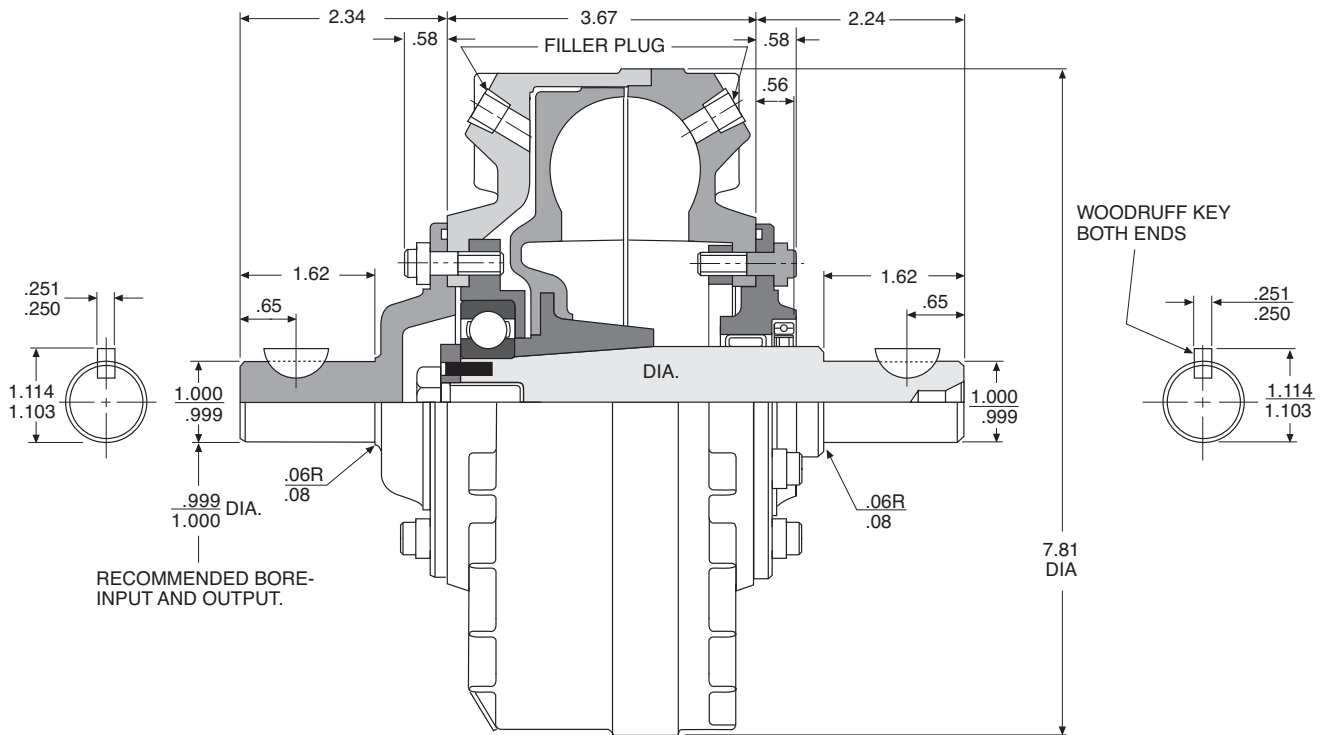

## Installation Procedure

This coupling is a complete unit and is to be installed between two piloting type flexible couplings provided by user. Install in the following sequence:

1. Assemble flexible couplings to shaft.—  
(T.B. Woods Formflex AJ15 or Equiv.)
2. Align shafts within .005 total indicator reading.
3. Install fluid coupling.
4. Lubricate flexible coupling per manufacturer's instructions.

# Model HSD

## Input and Output Side

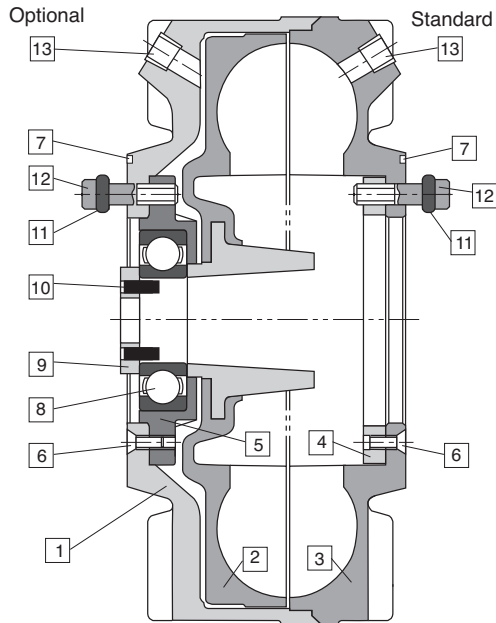

**Base Unit**  
8-607-100-000-0

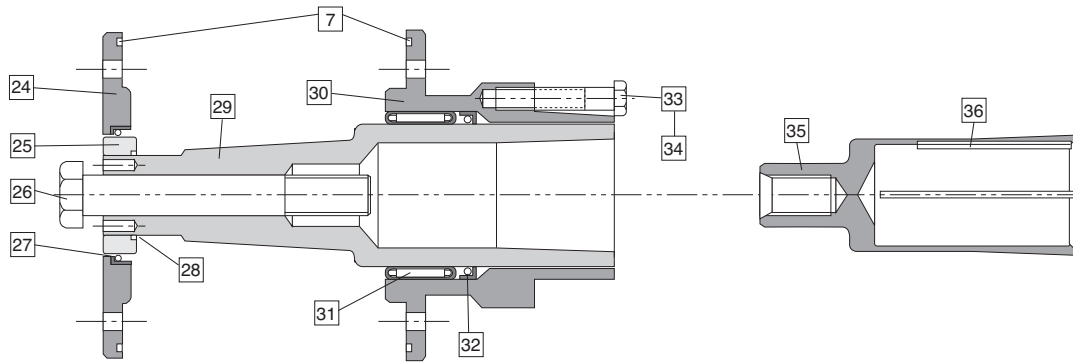

**HSD Input and Output**  
8-607-005-003-4

**Collet**

Item	Description	Qty.	Part Number	Item	Description	Qty.	Part Number
1	Front Cover	1	Items 1-6 are	24	End Cap	1	4-607-046-000-4
2	Runner	1	components of	25	Seal Bushing	1	4-607-043-000-4
3	Impeller	1	subassembly	26	Draw Bolt	1	2-173-037-034-0
4	Retaining Ring	1	8-607-001-000-0	27	Oil Seal	1	2-730-012-001-1
5	Input Bearing Carrier	1		28	O-Ring	1	2-740-009-001-1
6	Flathead Capscrew	4		29	Input Shaft	1	4-607-015-003-4
7	O-Ring	2	2-756-037-000-3	30	Sheave Hub	1	4-607-001-007-2
8	Ball Bearing	1	2-701-009-000-1	31	Needle Bearing	1	2-721-018-000-1
9	Retaining Washer	1	4-607-026-000-4	32	Oil Seal	1	2-730-022-000-1
10	Roll Pin	2	2-105-012-050-2	33	1/4" NC 11/4 Blt.	3	2-172-025-012-0
11	O-Ring	12	2-756-002-000-1	34	1/4" NC 13/4 Blt.	3	2-172-025-016-0
12	12 Point Screw	12	2-197-025-007-0	35	Collet	1	See page 10
13	Fill Plug	2	2-221-003-420-1	36	Step Key	1	See page 10



## Assembly Instructions

**Note:** Tapers to be cleaned with suitable solvent, wiped dry prior to assembly. Do not use molybdenum disulfide or equivalent friction reducing compounds on fasteners or taper.

1. If seal and needle bearing are not in place in sheave hub, install them.
2. Install "O" ring in sheave hub. Mount sheave hub to coupling face using the six 12 point capscrews with "O" rings. Tighten capscrews to 11-13 lb.ft. torque.
3. Install ball bearing into front bearing carrier. Care must be taken not to damage front cover adjacent to flat head screws.
4. To install input shaft, seal bushing with "O" ring, end cap assembly, and retaining ring.
  - a) Install input shaft through sheave hub and into taper in runner hub. Press shaft through ball bearing until it overhangs bearing 3/8 to 7/16 inch.
  - b) Install seal bushing with "O" ring onto overhung end of shaft.
  - c) If seal is not in place in end cap install it.
  - d) Mount end cap assembly with "O" ring and six 12 point capscrews with "O" rings. Tighten to 11-13 lb.ft. torque.
  - e) Install roll pins in retainer washer. Place retainer washer with roll pins over shaft end making sure pins align with holes in shaft.
  - f) Insert capscrew through retainer washer. Tighten capscrew to 38-42 lb.ft. torque.
  - g) To install collet, loosen capscrew. Insert collet and engage screw hand tight for shipment purposes only.
5. Check air tightness with 5-10 psi pressure applied thru one fill hole.

## Service Disassembly Instructions

1. Remove the two pipe plugs in the front cover and impeller, allow fluid to drain completely.
2. Remove six 12 point capscrews and "O" rings from end cap and coupling. Remove end cap and "O" ring.

3. Remove hex head capscrew which retains the collet. Remove retainer washer with roll pins.
4. Remove seal bushing and "O" ring from shaft end.
5. Insert push rod\* through hole in input shaft to bottom of tapped hole in collet. Use a capscrew\* in end of input shaft and tighten against push rod to break taper between input shaft and collet. Use flats on shaft end to counter wrench torque on screw. It may be necessary to tap end of capscrew to break taper contact.
6. Remove input shaft and coupling assembly with sheave from collet. Remove the 3 capscrews retaining the sheave. Remove sheave from sheave hub.
7. Remove six 12 point capscrews and "O" rings from sheave hub and coupling. Remove hub assembly and "O" ring.
8. If removal of bearing and seal from sheave hub is necessary, use a rod and tap from sheave side to remove.
9. Remove pusher rod from collet. Remove collet from motor shaft.
10. To remove input shaft, support runner on a tube\* and press input shaft from runner. Use plug against input shaft to protect threads in shaft.
11. To remove ball bearing, use a rod to tap out from sheave end.

**Note:** If the front cover and impeller assembly is damaged, the basic unit must be replaced.

### \* Tools required for disassembly

1. Push rod (.25 dia. x 3.00 long steel hardened to Rc50 min.)
2. Tube (2.50 O.D. x 2.12 I.D. x 5.00 long)
3. Capscrew (1/2-13 NC x 1.00 long)

### Recommended replacements for overhaul

1. Seals
2. Bearings
3. "O" rings

Repair Kit No.

8-607-005-001-2 - Major Repair Kit, includes 1, 2 & 3

8-607-005-000-2 - Minor Repair Kit, includes 1 & 3 only.

## Model HBM

Assembly No. see chart below

Input and Output — See chart below

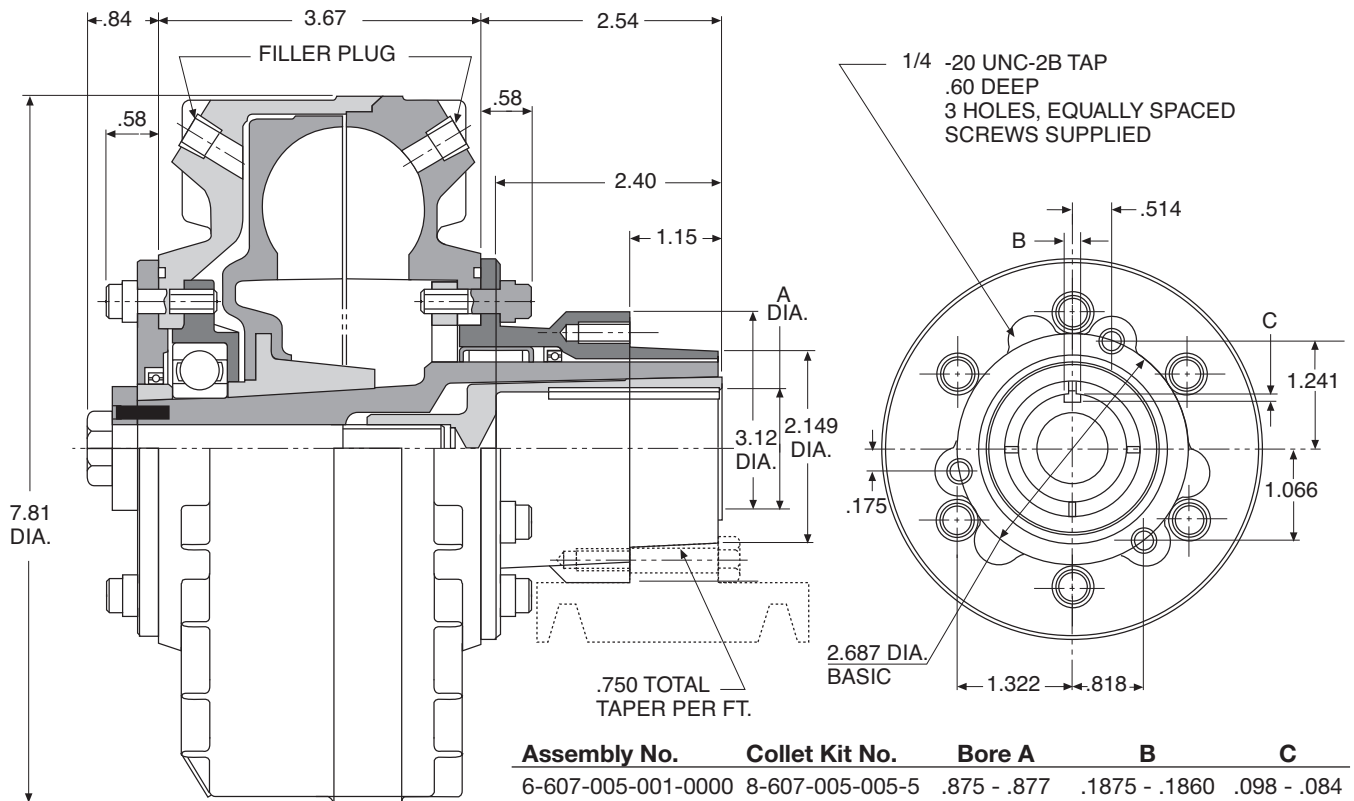

## Installation Procedure

This fluid coupling (hydro sheave) is a complete unit and is to be installed on the end of a drive shaft with a sheave mounted on the fluid coupling. Install in the following sequence

1. Install stepped key flush with end of drive shaft.
2. Install selected sheave to sheave assembly hub. Tighten capscrews to 8-9 lb. ft. torque.
3. Install coupling assembly on drive shaft. (It may be necessary to free the collet by pushing on loosened center capscrew.) Make sure collet does not ride up any radius for shoulder on the drive shaft.

**Note:** Shaft must protrude into the collet 2.00 in. min. tighten exposed center capscrew to 38-42 lb. ft. torque.

**CAUTION** The hydro sheave is installed on the end on a shaft and it is essential that a guard be provided.

Suitable sheaves are available from many manufacturers. QD sheaves should be made for SD and SDS hubs.

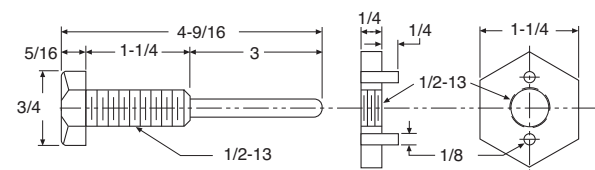

Removal Tool  
8-607-071-001-0

## Vertical Mounting for HSD

When mounting vertically, the motor and collet should be mounted above the sheave and fluid coupling.

This position insures even the smallest oil fill will react with the motor. Also, this position allows for addition of and maintenance of the oil level within the fluid coupling.

Order unit with standard and optional fill plugs.

## Fluid Recommendation

### Oil: SAE 10W

Castrol: Hyspin AWS 32      Shell: Tellus 32  
 Chevron: Hydraulic Oil EP 32      Texaco: Rando HD 32  
 Esso: Nuto H 32      Total: Azolla ZS 32  
 Mobil: DTE Oil Light

### Fire Resistant Fluid

Fyrquel: 220

## Filling Instructions

Fluid couplings are not filled at the factory. They must be filled after assembly or installation but before operation as follows:

1. Remove one pipe plug.
2. Fill with the proper fluid in proper quantity as required by the application

**Note:** 18.5 fl.oz. = Fill #8  
 21 fl.oz. = Fill #9  
 23 fl.oz. = Fill #10  
 25.5 fl.oz. = Fill #11  
 27.5 fl.oz. = Fill #12

3. Replace fill plug in fill hole using pipe sealant or teflon tape.
4. Change oil every 4,000 hours or once a year and fire resistant fluid every 10,000 hours or once every two years.

## Petroleum Oil

HP	Coupling Size	1200 RPM		1800 RPM			3600 RPM		
		Fill No.	% Slip	Coupling Size	Fill No.	% Slip	Coupling Size	Fill No.	% Slip
1/2	7.0	12	6	7.0	8	3			
3/4				7.0	8	4			
1				7.0	9	4			
1-1/2				7.0	11	5			
2				7.0	12	6			
3									
5									
7-1/2							7.0	8	4
10							7.0	8-1/2	4-1/2
15							7.0	10	4-1/2
20							7.0	10-1/2	5-1/2

**Note 1:** For vertical mounting, order unit with standard optional fill plugs.

**Note 2:** Reduced power capability when mounted vertically. Consult factory

## Application Notes

1. Max allowable operating speed: All models 3600 RPM
2. Select sheave, verifying that:
  - a. HP and speed of sheave and belts do not exceed manufacturers recommendations.
  - b. Sheave does not interfere with motor frame when motor shaft protrudes 2.00 in. min. into collet.

**⚠CAUTION** 7% or higher slips may cause overheating if coupling is cycled too rapidly.

**For minimum operating temperature below -10°F, consult Warner Electric.**

## Warranty

Wichita/Warner Electric warrants that it will repair or replace (whichever it deems advisable) any product manufactured and sold by it which proves to be defective in material or workmanship within a period of one (1) year from date of original purchase for consumer, commercial or industrial use. This warranty extends only to the original purchaser and is not transferable or assignable without Wichita/Warner Electric's prior consent. This warranty covers normal use and does not cover damage or defect which results from alteration, accident, neglect, or improper installation, operation, or maintenance. Wichita/Warner Electric's obligation under this warranty is limited to the repair or replacement of the defective product and in no event shall Wichita/Warner Electric be liable for consequential, indirect or incidental damages of any kind incurred by reasons of manufacture, sale or use of any defective product. Wichita/Warner Electric neither assumes nor authorizes any other person to give any other warranty or to assume any other obligation or liability on its behalf.



Wichita Clutch  
2800 Fisher Road, Wichita Falls, TX 76032 - USA  
800-964-3262 • Fax: 940-723-3436  
[www.wichitaclutch.com](http://www.wichitaclutch.com)