

Warner Electric

Boston Gear

TB Wood's

Formsprag Clutch

Wichita Clutch

Marland Clutch

Industrial Clutch

Bauer Gear Motor

Nuttall Gear

Warner Linear

Delroyd Worm Gear

Stieber Clutch

Svendborg Brakes

Ameridrives Couplings

Inertia Dynamics

Matrix International

Huco Dynatork

Bibby Turboflex

Twiflex Limited

Kilian Manufacturing

Lamiflex Couplings

Ameridrives Power
Transmission

Metallic Flexible Coupling Service Life and Failure Modes



As seen in
Hydrocarbon Processing
January, 1996

Metallic Flexible Coupling Service Life and Failure Modes

James H. Paluh, Manager-Engineering
Zurn Industries, Inc., Mechanical Drives Division

Consider these design factors that contribute to reliability

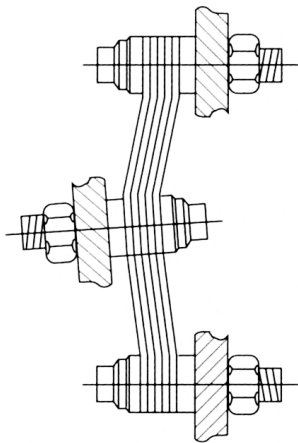

Figure 1: In disc couplings, torque is transmitted by the driving bolts pulling the driven bolts

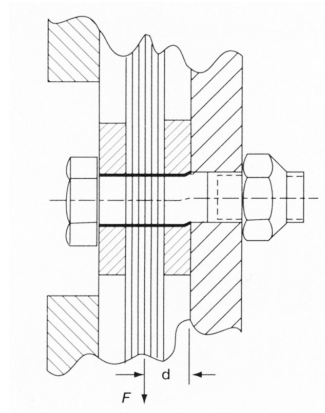

Figure 2: The highest bolt stresses are in bending for disc couplings.

Metallic disc and diaphragm are the two principle types of nonlubricated couplings used in high-performance turbomachinery. Both transmit torque and accommodate misalignment between turbomachinery equipment shafts. These types of couplings rely on the flexure of metallic membranes to accept angular and axial misalignment. Design differences contribute to reliability and service life calculations.

In disc couplings, torque is transmitted by the driving bolts pulling the driven bolts with the disc material at a constant bolt circle (Fig. 1). The disc elements generally consist of many thin, metallic, identically-shaped rings stacked directly on top of one another. The ring shape will vary by design such as circular, hex, or scalloped discs. The discs are clamped together with washers by bolts that are attached alternately to the driving and driven flanges.

In diaphragm couplings, the torque is transmitted radially from the outside diameter of a drive flange through one or more metallic plates to an attachment at the inside diameter. The diaphragms may have either a constant or tapered thickness and may be flat, convoluted or spoked. The diaphragm outside diameter is usually clamped by bolts while the inside diameter is unitized by electron beam welds, splines or bolts.

Reliability Factors

While disc couplings have multiple membranes, the individual discs are typically not separated. When disc flexing occurs under misalignment, each disc contacting surface rubs the adjoining disc surface causing some degree of fretting and wear. This fretting can allow corrosion to attack the disc material. When corrosion is combined with fatigue, known as corrosion fatigue, it reduces the endurance limit and may initiate a fatigue failure. The corrosion products can act as a wedge, opening a crack in the fretted area of the disc. Since there is direct contact with the adjoining discs, the crack could propagate quickly. By properly designing the shape (such as scalloping) and the thickness of the discs, fretting corrosion can be reduced, but not eliminated.

Some manufacturers apply coatings to each disc to increase the finite coupling life. However, studies have shown that most coatings have a negative impact on the base material endurance strength.

Stress corrosion cracking is defined as the combined action of static stress and corrosion leading to metal cracking or embrittlement and must be considered in metallic membrane material selection. Standard disc materials are austenitic stainless

steels such as 301 full hard. In corrosive environments such as atmospheric sodium chloride, austenitic stainless steels are highly susceptible to stress corrosion cracking when the temperature exceeds 150°F. Most disc coupling manufacturers offer alternate materials such as Inconel that are highly resistant to stress corrosion.

For diaphragm couplings, testing has shown that 15-5 PH age hardened to H1025 is highly resistant to stress corrosion cracking, even at sustained stress levels much greater than the diaphragm stresses. Shot peening can provide a surface layer of compressive stress on both sides of every diaphragm. Stress corrosion cracking can not occur in an area of compressive stress.

The design and proper installation of the disc coupling bolts is also critical since the inherent design of disc couplings requires the bolts to transfer torque through shear and bending. The highest bolt stresses are in bending (Fig. 2). This is in contrast to a typical diaphragm coupling flange-to-flange connection where torque subjects the bolts predominately to shear stresses. Proper disc coupling bolt tension not only decreases the bolt bending stress to acceptable levels, but affects fretting and corrosion fatigue characteristics of the disc surface at the washer interface.

Although disc couplings may have extremely long life, it is not infinite. Life of identical disc coupling designs in the same application at different sites can vary due to the actual equipment misalignment, the preload in the individual bolts and the specific environmental conditions. Adhering to the manufacturer's recommended bolt tightening torque and minimizing misalignment will assure the longest service life. Experience with the specific turbomachinery equipment must be considered when establishing maintenance and inspection intervals.

Life Analysis

Disc life analysis is complicated by fretting caused by coupling misalignment. Manufacturers typically calculate safety factors using the classical fatigue failure theories such as the modified Goodman diagram, but do not reduce the disc raw material endurance limit caused by corrosion fatigue, wear, or coatings. Published raw material endurance limits are not intended to consider wear with fatigue or the coating effects. Users should exercise caution when reviewing such data and consider the manufacturer's experience and disc life history for similar applications. Either a reduction of endurance properties or higher safety or service factors may be required. Some manufacturers may require a minimum service or application factor. A bolt fatigue analysis should be performed in high-torque applications due to the high bending stresses. This will ensure that the fatigue analysis is performed on the coupling's component with the lowest safety factor. Following these guidelines will help assure long disc coupling service life in typical high-performance turbomachinery.



Figure 3: The diaphragms will shear from the spool preventing transfer of power.

Design Improvements

Diaphragm couplings can incorporate life and safety factors that are not present in disc coupling designs. The metallic membranes can consist of thin, multiple, convoluted and separated diaphragms. Each of these properties provides a benefit to the overall coupling design. The diaphragm life is not dependent on the operating angle within its design rating.

The flex area is separated at the inside and outside diameters and then rigidly clamped. This separation prevents fretting corrosion from angular and axial misalignment usually associated with the rubbing of the flexing areas of multiple membrane couplings. Since there is no fretting, the designer can legitimately use classical infinite life engineering fatigue analysis for the diaphragm design utilizing the raw material properties. No reduction in the diaphragm material endurance limit or decreased reliability is caused by fretting corrosion or wear of the flex area. Using the appropriate stresses confirmed by finite element analysis and strain gage testing, safety factors can be accurately calculated using any of the fatigue failure theories such as Goodman, modified Goodman, or Constant Life. In operation, this translates into predictable equipment maintenance and inspection intervals regardless of the angular and axial misalignment within the coupling's design rating, environmental conditions and the length of service.

In the event of failure, a disc coupling and a diaphragm coupling affect the system differently. If a failure occurs in a disc coupling either in fatigue by fretting corrosion or ultimate failure due to a peak torque overload, the driving flange bolts will continue to load

the driven flange bolts and drive the equipment. The flailing and high bending loads that occur in this condition may cause significant damage to adjoining equipment and high vibration. Adequate vibration monitoring, plus typical overspeed trip devices are critical to prevent further damage to connected equipment.

Conversely, if a separated diaphragm coupling was subjected to excessive misalignment that initiated a fatigue failure, the crack would propagate gradually due to the separation of the diaphragm flex areas. Eventually, as each diaphragm fails, the remaining diaphragms will shear at their inside diameter due to excessive torque. Most importantly, regardless of the cause of failure, by fatigue or ultimate failure, the diaphragm inside diameter will shear from the spacer or spool preventing the transfer of power from the driving to driven equipment (Fig. 3). The instantaneous loss of load will result in a standard turbomachinery overspeed trip. After shear failure, anti-flail guards can contain the center section for safety and protect the adjoining equipment.



An Altra Industrial Motion Company

US (Customer Service)

814-480-5000

www.ameridrivescouplings.com

Asia Pacific

For a list of our AP sales offices:

www.AltraMotion.com/ContactUs