



Fractional HP Clutches/Brakes



Table of Contents



Fractional HP Clutches/Brakes

Features..... Page 3

Selection Guide..... Pages 4 - 5



SF Series clutches provide a bearing mounted clutch for use in parallel shaft applications. SF clutches easily adapt to a customer provided pulley, sprocket or gear to transmit torque between two shafts. Pages 6 - 7

SFP Series units provide a bearing mounted field/rotor assembly with a bearing mounted output hub suitable for mounting of pulley or sprocket. Pages 8 - 9

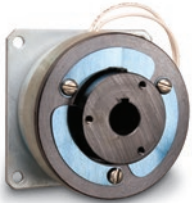

SFC Series clutches provide a bearing mounted clutch coupling for use in transmitting torque between two in-line shafts. Pages 10 - 11

PB Series brakes provide a flange mounted brake design for accurate stopping of rotating shafts. Pages 12 - 13



SFPB Series provides a clutch (SF) and brake (PB) combination for use with pulley or sprocket input. The clutch and brake are mounted back-to-back with a torque arm to provide for simplicity of mounting. Page 14

SFPBC Series provides a clutch coupling (SFC) and brake (PB) combination for coupling two in-line shafts. The clutch coupling and brake are mounted back-to-back with a torque arm to provide for simplicity of mounting..... Page 15

Selection Criteria..... Pages 16 - 17

How to Order Page 18

Power-On Clutches & Brakes Description

Features

Screw Terminals Standard On Larger Sizes; Smaller Sizes with Leads, UL Recognized Materials

Field Assembly

Sealed Ball Bearings Standard On Larger Sizes; Sintered Bronze On Smaller Sizes

Coils with UL Recognized Materials

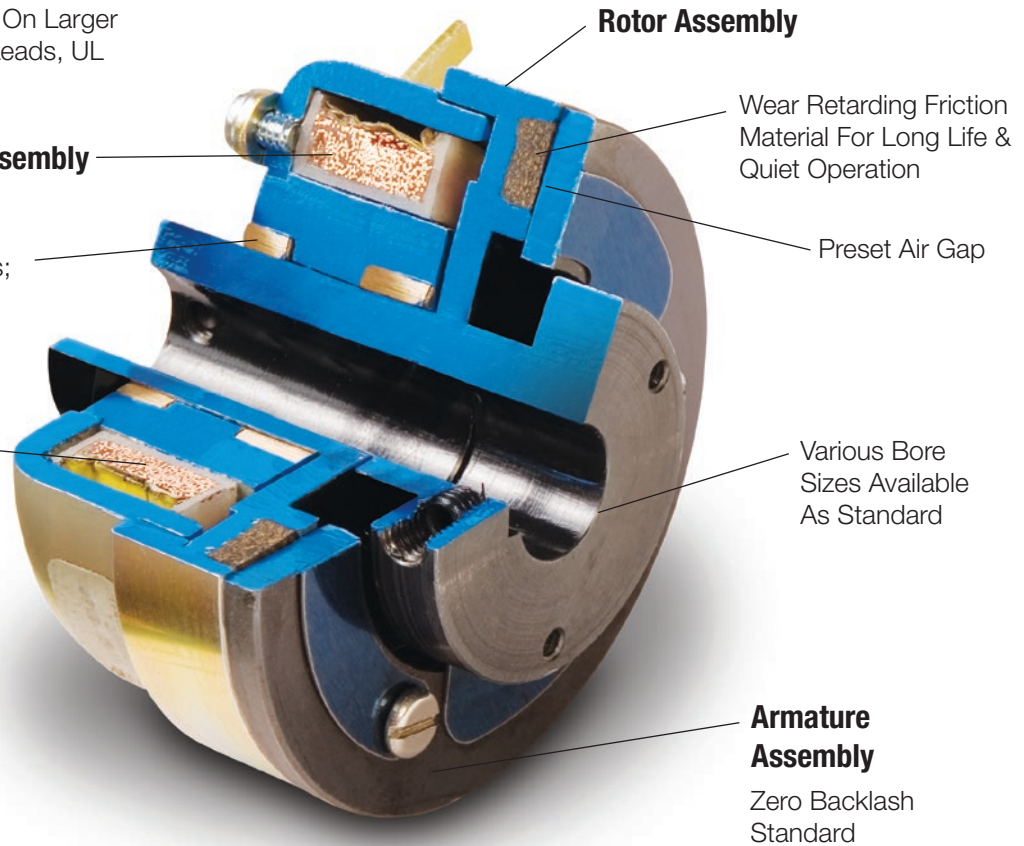

Wear Retarding Friction Material For Long Life & Quiet Operation

Preset Air Gap

Various Bore Sizes Available As Standard

Armature Assembly

Zero Backlash Standard

Typical Applications of Clutches & Brakes

- Copiers/Printers
- Packaging Machinery
- Microfilm Readers
- Medical Equipment
- Conveyors
- Postal Sorters/Readers
- Document Feeders
- Textile Equipment

Generating the Clutch or Brake Torque

Warner Electric™ clutches and brakes are designed to start and stop inertial loads when the voltage is turned on. When DC voltage is applied to the coil, the magnetic force caused by the magnetic flux pulls the armature across the air gap against the force of the zero-backlash spring attached to the armature. The mating of the armature and rotor face transmit torque.

When DC voltage is interrupted, the magnetic field collapses, and the zero-backlash spring retracts the armature from the rotor face. There is no residual torque produced.

Special Features of Warner Electric Clutches and Brakes

- Precision centered sleeve and ball bearings for long life
- Zero-backlash armature assembly providing a spring release for reliable and precise disengagement
- Stationary field coil assembly means no slip rings or brushes.
- All parts effectively protected against corrosion.
- Asbestos-free friction material
- Non-standard coil voltages available upon request
- Metric bore sizes available upon request
- Conforms to ROHS standards

How To Select

Selection Process

STEP 1

These graphics provide a visual guide to unit mounting in a typical installation.

PB

The brake will be mounted on a driven shaft with the magnet secured to the machine frame. When engaged, the brake will bring the rotating load to a stop and hold until power is removed.

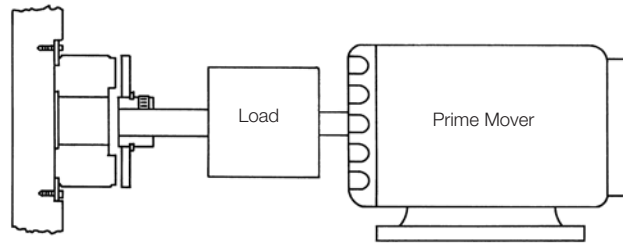

PB

SF/SFP

The SF or SFP clutches are designed for parallel shaft mounting and will connect to the load via a chain or belt drive. The clutch can be mounted to either a driving or driven shaft.

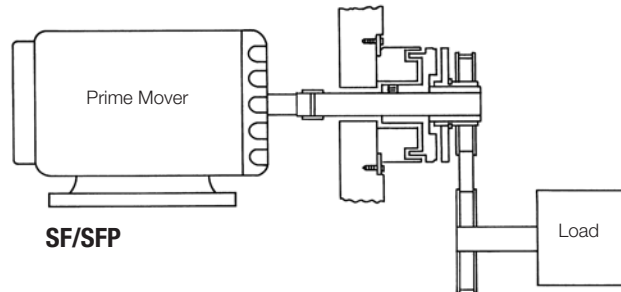

SF/SFP

SFC

The SFC clutches are designed for use with two in-line shafts. Half of the clutch will mount to the driving shaft and the other half to the driven shaft. When engaged the unit will couple the two shafts together.

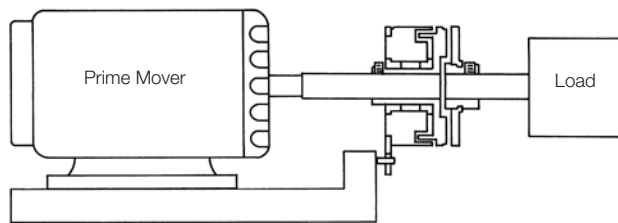

SFC

SFPB

This clutch/brake combination will be mounted on a driven shaft with the brake located closest to the load. SFPB units are designed for parallel shaft mounting and will have input from a chain or belt drive. When the clutch is engaged, it will drive the load, when the brake is engaged, the load will be stopped and held, and the clutch input will rotate.

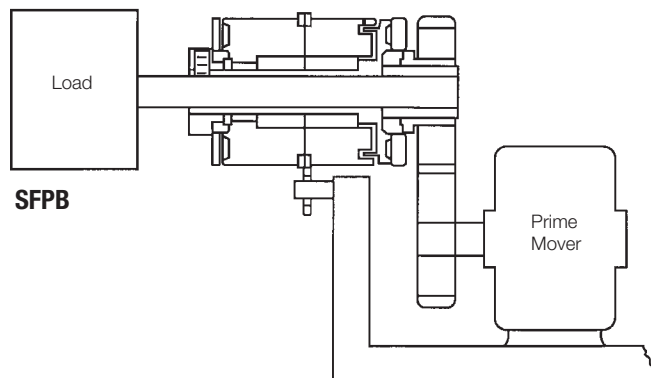

SFPB

SFPBC

This clutch/brake combination will be used with two in-line shafts with the brake on the driven shaft. When clutch engaged, the clutch will couple the two shafts together. With brake engaged, the driven shaft and load will be stopped and held while the input half of the clutch will rotate freely on the driving shaft.

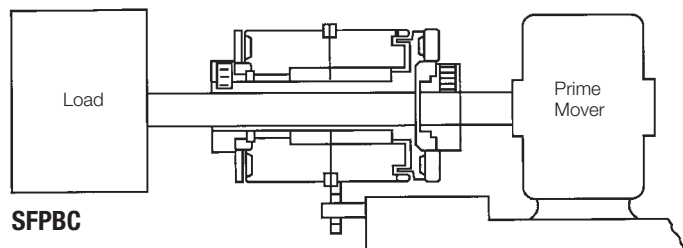

SFPBC

STEP 2

Determine the shaft speed at the clutch or brake location. Whenever possible locate the clutch or brake at the highest speed shaft available to perform the desired task. A higher speed will provide a lower torque requirement and therefore a smaller clutch or brake.

STEP 3

Use the chart below to find the intersection of the speed and torque for your application. This will provide the unit size.

STEP 4

Using the appropriate catalog page confirm unit dimensions and mounting. Provide unit bore size(s) and coil voltage.

For additional calculation formulae and dynamic torque curves, please refer to page 14.

Shaft Speed at Clutch (In RPM)

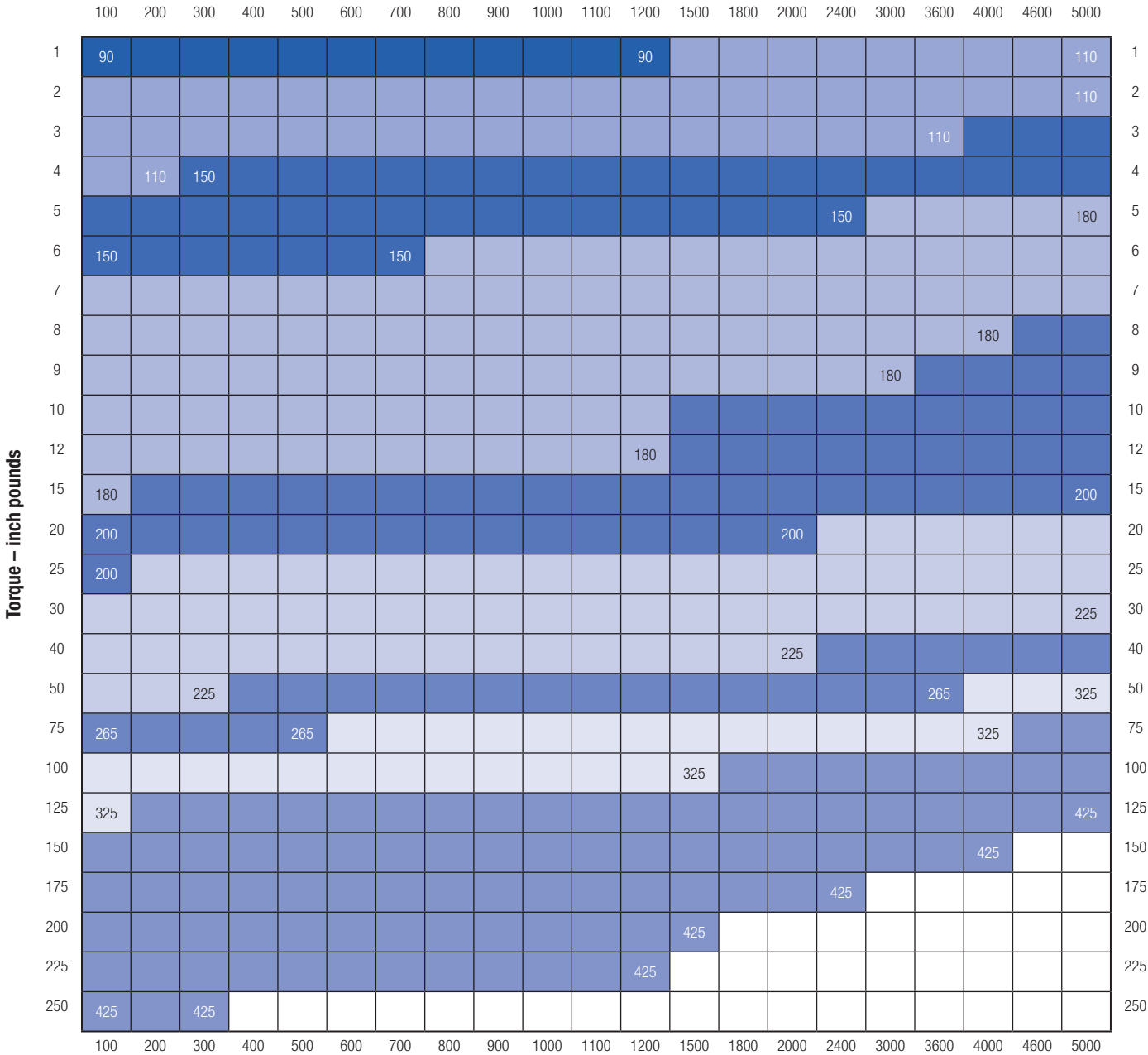

SF Series

Stationary Field Clutch for Parallel Shafts Models 090-265

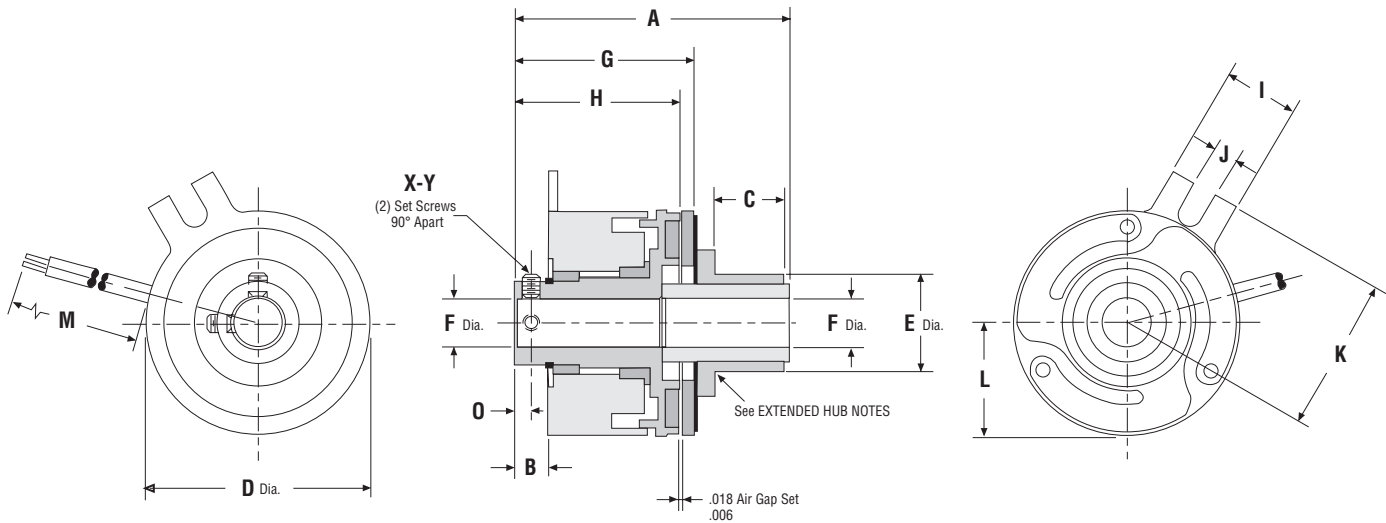

Dimensions

Model No.	A Max.	B Nom.	C Max.	D Max.	E ± .002	F Nom.	G Nom.	H Nom.	I Max.	J Min.	K Nom.	L Nom.	M ± .500	O Nom.	Rotor Keyway			
															Bore	Nominal Keyway		
																X	Y	
090	1.370	0.191	0.410	0.903	0.507 Knurl	1/8 3/16 1/4	0.874	0.763	0.305	0.094	0.625	0.445	12.00	0.080	N.A.	Set Screws Only		
110	1.409	0.147	0.396	1.160	0.506 Knurl	3/16 1/4 5/16	0.935	0.777	0.380	0.122	0.875	0.585	12.00	0.087	N.A.	Set Screws Only		
150	1.695	0.275	0.250	1.500	0.622	1/4 5/16 3/8	1.255	1.075	0.520	0.180	1.120	0.750	12.00	0.125	N.A.	Set Screws Only		
180	1.823	0.279	0.250	1.780	0.622	1/4 5/16 3/8	1.316	1.060	0.505	0.184	1.325	0.975	12.00	0.125	N.A.	Set Screws Only		
200	1.948	0.279	0.250	2.000	0.622	5/16 3/8	1.329	1.060	0.505	0.184	1.325	0.975	12.00	0.125	5/16 3/8	.0625 - .0655 .094 - .097	.347 - .352 .417 - .427	Set Screws
225	2.160	0.281	0.238	2.260	0.872	3/8 1/2	1.578	1.423	0.442	0.170	1.515	1.160	18.00	0.117	3/8 1/2	.094 - .097 .125 - .128	.417 - .427 .560 - .567	
265	2.454	0.280	0.472	2.645	0.998	3/8 1/2 5/8	1.740	1.437	0.510	0.190	1.750	1.465	18.00	0.154	3/8 1/2 5/8	.094 - .097 .125 - .128 .1885 - .1905	.417 - .427 .560 - .567 .709 - .716	

EXTENDED HUB NOTES:

1. Extended armature hubs Models 150, 180 and 200 (3) #4-40 tapped holes on a .812 BC
2. Extended armature hub Model 225 (3) #6-32 tapped holes on a 1.187 BC
3. Extended armature hub Model 265 (3) #8-32 tapped holes on a 1.375 BC

Mechanical

Model No.	Static Torque lb. - in.	Inertia lb. - in. ²		Wt. oz.
		Rotor	Arm & Hub	
090	2.5	0.002	0.0015	2.0
110	6	0.0058	0.0029	3.2
150	10	0.060	0.0031	3.8
180	15	0.061	0.036	11
200	25	0.082	0.047	12
225	50	0.215	0.079	20
265	80	0.362	0.292	28

Electrical

Model No.	90 VDC		24 VDC		12 VDC	
	Amps	Ohms	Amps	Ohms	Amps	Ohms
090	0.046	1977	0.117	205	0.246	48.8
110	0.047	1930	0.198	121	0.447	26.8
150	0.042	2150	0.183	132	0.380	31.6
180	0.066	1369	0.289	83	0.561	21.4
200	0.074	1213	0.294	81.6	0.574	20.9
225	0.079	1140	0.322	74.6	0.628	19.1
265	0.092	980	0.374	64.2	0.760	15.8

Lead wire is UL recognized style 1213, 1015 or 1430, 22 gage.

Insulation is .0509 O.D. on 090, 110, 150 units; .0649 or .0959 O.D. on all other units.

Stationary Field Clutch for Parallel Shafts Models 325-425

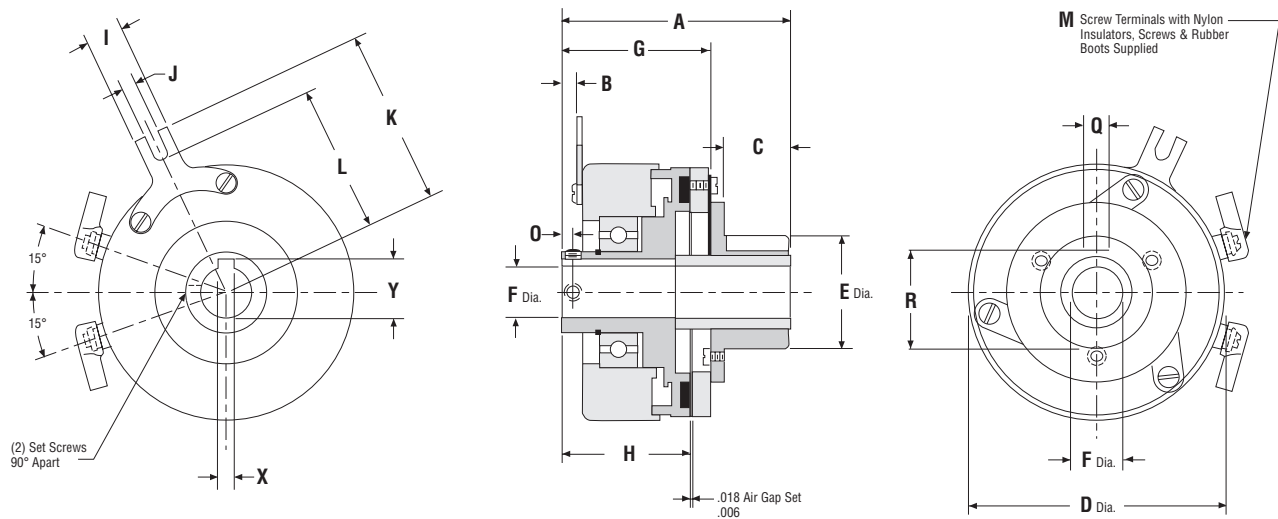

Dimensions

Model No.	A Max.	B Nom.	C Max.	D Max.	E ±.002	F Nom.	G Nom.	H Nom.	I Max.	J Min.	K Nom.	L Nom.	M	O Nom.	Rotor Keyway		
															Bore	Nominal Keyway	
																X	Y
325	2.800	0.250	0.830	3.268	1.374	1/8 1/2 5/8 3/4	1.815	1.390	0.442	0.170	2.050	1.695	Screw Terminals	0.135	1/2 5/8 3/4	.125 - .128 .1885 - .1905 .1885 - .1905	.560 - .567 .709 - .716 .836 - .844
425*	3.820	0.320	1.560	4.270	1.374	1/2 5/8 3/4 7/8 1	2.050	1.625	0.645	0.190	2.500	2.312	Screw Terminals	0.187	1/2 5/8 3/4 7/8* 1*	.125 - .128 .1885 - .1905 .1885 - .1905 .1885 - .1905 .251 - .253	.560 - .567 .709 - .716 .836 - .844 .962 - .970 1.113 - 1.121

* 7/8 and 1 inch bore in rotor only.

Mechanical

Model No.	Static Torque lb. - in.	Inertia lb. - in. ²		Wt. oz.
		Rotor	Arm & Hub	
325	125	0.610	0.561	50
425	250	2.50	2.30	85

Electrical

Model No.	90 VDC		24 VDC		12 VDC	
	Amps	Ohms	Amps	Ohms	Amps	Ohms
325	0.091	988	0.378	65.3	0.729	16.5
425	0.124	722	0.468	51.2	0.934	12.84

Lead wire is UL recognized style 1213, 1015 or 1430, 22 gage.

Insulation is .0509 O.D. on 090, 110, 150 units; .0649 or .0959 O.D. on all other units.

Customer shall maintain:

- A loose-fitting pin through the anti-rotation tab to prevent preloading the bearings.

SFP Series

Pre-Assembled SF Clutch For Parallel Shafts Models 110-180

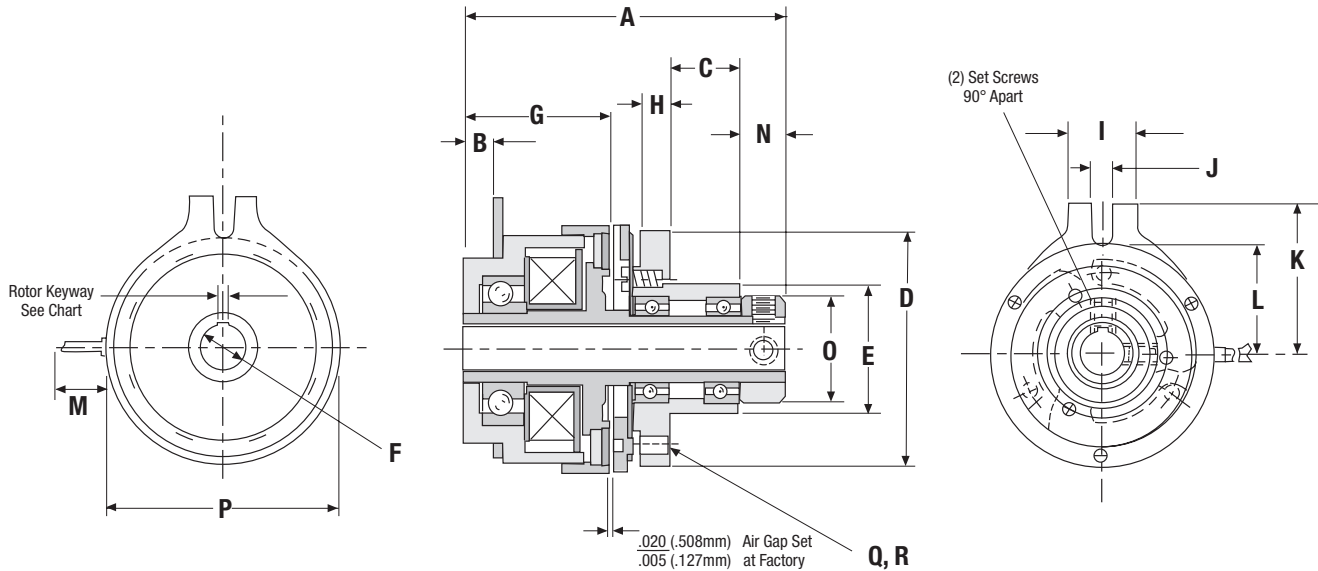

Dimensions

Model No.	A Max.	B Max.	C Nom.	D Max.	E ± .001	F Nom.	G Nom.	H Nom.	I Max.	J Min.	K Nom.	L Nom.	M ± .500	N Nom.	O Nom.	P Max.	Rotor Keyway		Q B.C.	R Size
																	Bore	Nominal Keyway		
110	1.785	0.184	0.405	1.380	0.7485	3/16 1/4	0.812	0.163	0.380	0.125	0.875	0.625	12.00	0.250	0.625	1.285	N.A.	Set Screws Only	1.125 3-Holes	6-32 UNC-2B
180	2.515	0.304	0.500	1.755	0.9985	1/4 5/16 3/8	1.290	0.193	0.505	0.184	1.325	0.975	12.00	0.315	0.875	1.620	N.A.	Set Screws Only	1.437 3-Holes	8-32 UNC-2B

Mechanical

Model No.	Static Torque lb. – in.	Inertia lb. – in. ²		Wt. oz.
		Rotor	Arm & Hub	
110	6	0.013	0.030	8
180	15	0.052	0.095	26

Electrical

Model No.	90 VDC		24 VDC		12 VDC	
	Amps	Ohms	Amps	Ohms	Amps	Ohms
110	0.048	1848	0.188	120	0.447	26.8
180	0.066	1369	0.289	83.1	0.561	21.4

Customer shall maintain:

- A loose-fitting pin through the anti-rotation tab to prevent preloading the bearings.

Pre-Assembled SF Clutch For Parallel Shafts Models 265-425

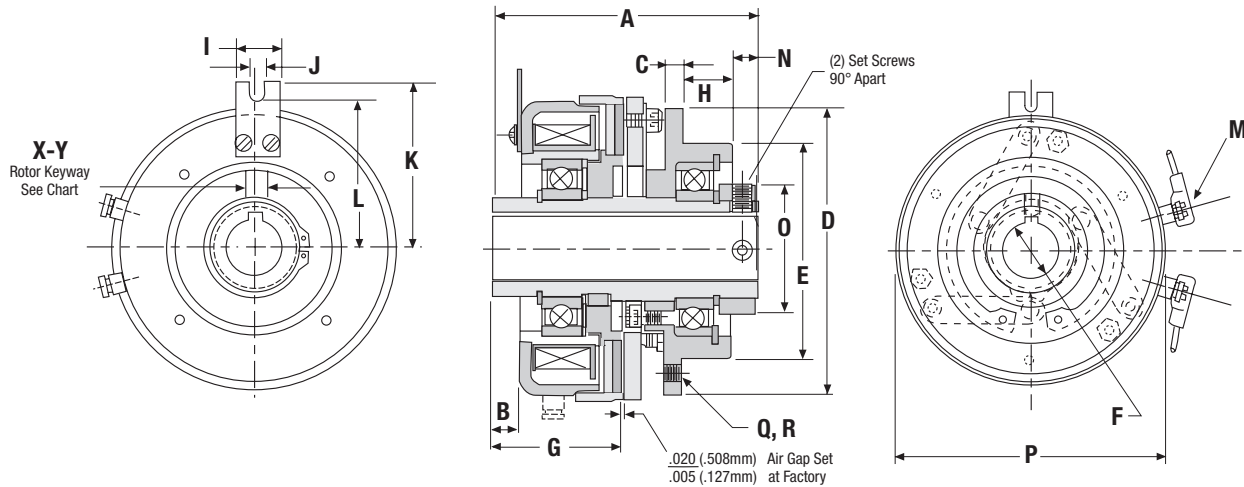

Dimensions

Model No.	A Max.	B Max.	C Nom.	D Max.	E ± .001	F Nom.	G Nom.	H Nom.	I Max.	J Min.	K Nom.	L Nom.	M	N Nom.	O Nom.	P Max.	Rotor Keyway			Q B.C.	R Size
																	Bore	Nominal Keyway			
																		X*	Y*		
265	2.930	0.140	0.260	2.505	1.498	1/2 5/8	1.375	0.500	0.510	0.190	1.750	1.467	Screw Terminals	0.420	1.187	2.645	1/2 5/8	.125 - .128 .1885 - .1905	.560 - .567 .709 - .716	1.790 3-Holes	6-32 UNC-2B
325	2.961	0.140	0.395	2.883	1.498	1/2	1.360	0.500	0.442	0.170	2.050	1.740	Screw Terminals	0.408	1.187	3.300	1/2	.125 - .128	.560 - .567	1.790 3-Holes	6-32 UNC-2B
425	3.350	0.000	0.267	4.015	2.999	3/4 7/8 1	1.405	0.673	0.645	0.188	2.500	2.216	Screw Terminals	0.383	1.810	4.270	3/4 7/8 1	.1885 - .1905 .1885 - .1905 .251 - .253	.836 - .844 .962 - .970 1.113 - 1.121	3.500 3-Holes	1/4-20 UNC-2B

* 7/8 and 1 inch bore rotor only.

Mechanical

Model No.	Static Torque lb. - in.	Inertia lb. - in. ²		Wt. oz.
		Rotor	Arm & Hub	
265	80	0.290	0.530	38
325	125	0.560	0.990	54
425	250	2.250	4.990	94

Electrical

Model No.	90 VDC		24 VDC		12 VDC	
	Amps	Ohms	Amps	Ohms	Amps	Ohms
265	0.088	1024	0.358	67.1	0.760	15.8
325	0.091	988	0.378	65.3	0.729	16.5
425	0.124	722	0.468	51.2	0.934	12.84

Lead wire is UL recognized style 1213, 1015 or 1430, 22 gage.

Insulation is .0509 O.D. on 110 units; .0649 or .0959 O.D. on all other units.

Customer shall maintain:

- A loose-fitting pin through the anti-rotation tab to prevent preloading the bearings.

SFC Series

Stationary Field Clutch Coupling For In-Line Shafts Models 090-265

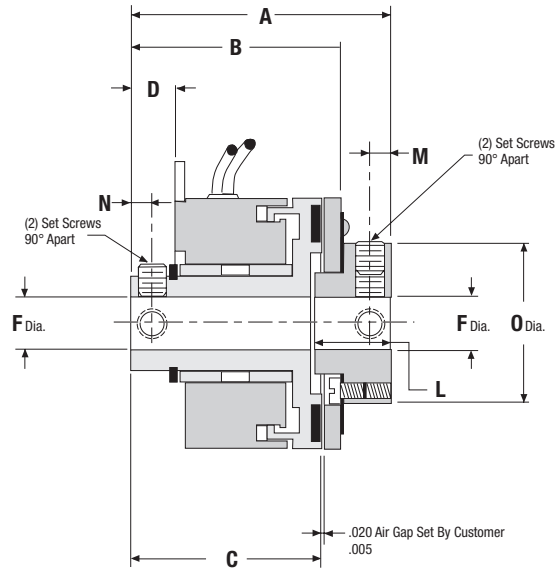
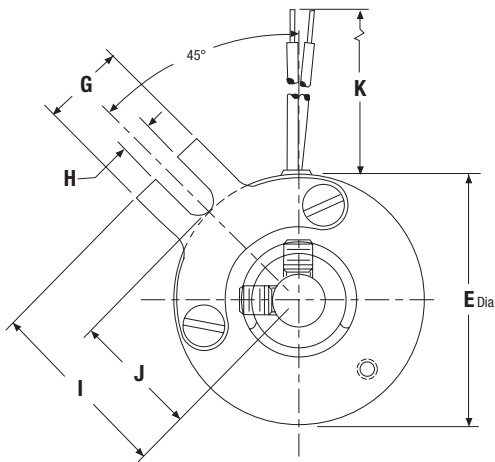

Dimensions

Model No.	A Max.	B Nom.	C Nom.	D Nom.	E Max.	F Nom.	G Max.	H Min.	I Nom.	J Nom.	K ± .500	Rotor Keyway		L Max.	M Nom.	N Nom.	O Max.	
												Bore	Nominal Keyway					
090	1.059	0.875	0.763	0.191	0.903	1/8 3/16 1/4	0.305	0.094	0.625	0.445	12.00	N.A.	Set Screws Only	0.237	0.070	0.080	0.500	
110	1.168	0.933	0.777	0.147	1.160	3/16 1/4 5/16	0.380	0.122	0.875	0.585	12.00	N.A.	Set Screws Only	0.307	0.093	0.087	0.687	
150	1.575	1.255	1.075	0.275	1.500	1/4 5/16 3/8	0.520	0.180	1.120	0.750	12.00	N.A.	Set Screws Only	0.475	0.125	0.125	0.965	
180	1.605	1.311	1.060	0.270	1.780	1/4 5/16 3/8	0.505	0.184	1.325	0.975	12.00	1/4 5/16 3/8	.0625 - .0655 .0625 - .0655 .094 - .097	.285 - .290 .347 - .352 .417 - .427	0.460	0.115	0.125	1.190
200	1.609	1.314	1.060	0.270	2.000	5/16 3/8 1/2	0.505	0.184	1.325	0.975	12.00	5/16 3/8 1/2	.0625 - .0655 .094 - .097 .125 - .128	.347 - .352 .417 - .427 .560 - .567	0.455	0.115	0.125	1.190
225	1.989	1.578	1.423	0.281	2.260	3/8 1/2	0.442	0.170	1.515	1.160	18.00	3/8 1/2	.094 - .097 .125 - .128	.417 - .427 .560 - .567	0.510	0.115	0.117	1.005
265	2.115	1.754	1.444	0.277	2.645	3/8 1/2 5/8	0.510	0.190	1.750	1.465	18.00	3/8 1/2 5/8	.094 - .097 .125 - .128 .1885 - .1905	.417 - .427 .560 - .567 .709 - .716	0.610	0.150	0.187	1.440

Mechanical

Model No.	Static Torque lb. - in.	Inertia lb. - in. ²		Wt. oz.
		Rotor	Arm & Hub	
090	2.5	0.002	0.0011	2
110	6	0.0058	0.0024	3.2
150	10	0.060	0.026	3.8
180	15	0.061	0.031	11
200	25	0.082	0.042	12
225	50	0.215	0.070	20
265	80	0.362	0.320	28

Electrical

Model No.	90 VDC		24 VDC		12 VDC	
	Amps	Ohms	Amps	Ohms	Amps	Ohms
090	0.046	1977	0.117	205	0.246	48.8
110	0.047	1930	0.198	121	0.447	26.8
150	0.042	2150	0.183	132	0.380	31.6
180	0.066	1369	0.289	83	0.561	21.4
200	0.074	1213	0.322	74.4	0.574	20.9
225	0.079	1140	0.322	74.6	0.628	19.1
265	0.092	980	0.374	64.2	0.760	15.8

Stationary Field Clutch Coupling For In-Line Shafts Models 325-425

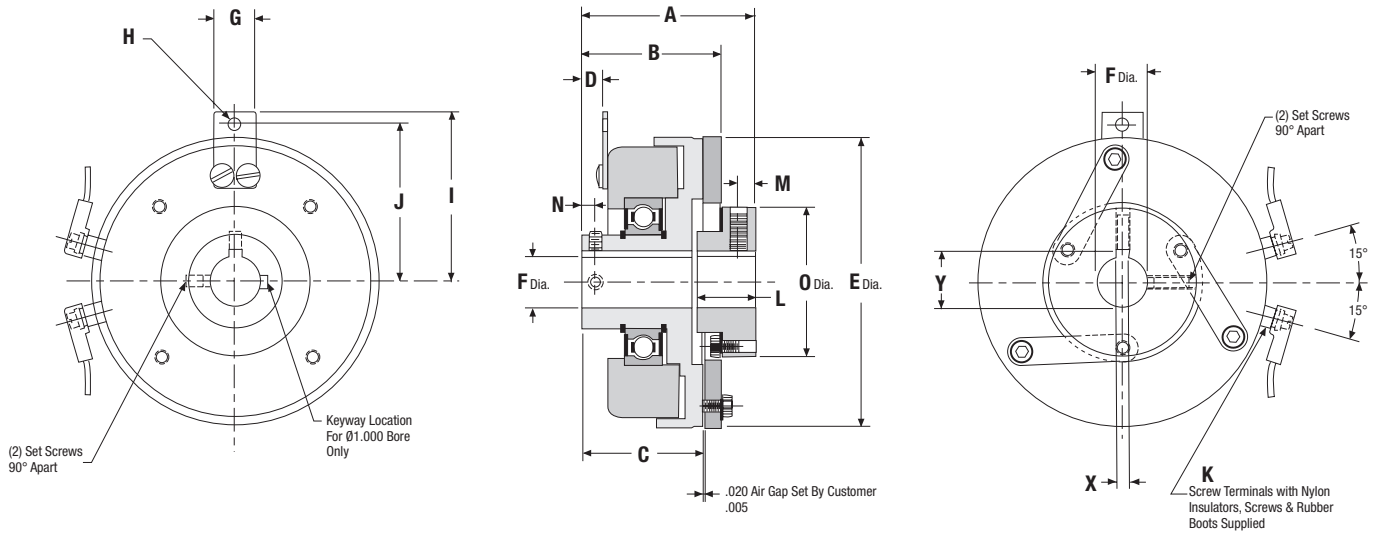

Dimensions

Model No.	A Max.	B Nom.	C Nom.	D Nom.	E Max.	F Nom.	G Max.	H Min.	I Nom.	J Nom.	K	Rotor Keyway						
												Bore	Nominal Keyway		L Max.	M Nom.	N Nom.	O Max.
													X	Y				
325	2.151	1.815	1.403	0.265	3.268	1/2	0.442	0.170	2.050	1.695	Screw Terminals	1/2	.125 - .128	.560 - .567	0.680	0.150	0.135	1.825
						5/8						.1885 - .1905	.709 - .716					
						3/4						.1885 - .1905	.836 - .844					
425	2.570	2.050	1.625	0.320	4.270	1/2	0.645	0.190	2.500	2.312	Screw Terminals	1/2	.125 - .128	.560 - .567	0.890	0.250	0.187	2.195
						5/8						.1885 - .1905	.709 - .716					
						3/4						.1885 - .1905	.836 - .844					
						7/8						.1885 - .1905	.962 - .970					
						1						.251 - .253	1.113 - 1.121					

Mechanical

Model No.	Static Torque lb. - in.	Inertia lb. - in. ²		Wt. oz.
		Rotor	Arm & Hub	
325	125	0.610	0.561	45
425	250	2.50	2.30	80

Electrical

Model No.	90 VDC		24 VDC		12 VDC	
	Amps	Ohms	Amps	Ohms	Amps	Ohms
325	0.091	988	0.378	65.3	0.729	16.4
425	0.124	722	0.468	51.2	0.934	12.84

Lead wire is UL recognized style 1213, 1015 or 1430, 22 gage.

Insulation is .050" O.D. on 110 units; .064" or .095" O.D. on all other units.

Customer shall maintain:

- A loose-fitting pin through the anti-rotation tab to prevent preloading the bearings.
- Concentricity between the shafts within .005 T.I.R.
- Initial airgap setting of .005 - .020 inches.

PB Series

Flange Mounted Brake Models 090-265

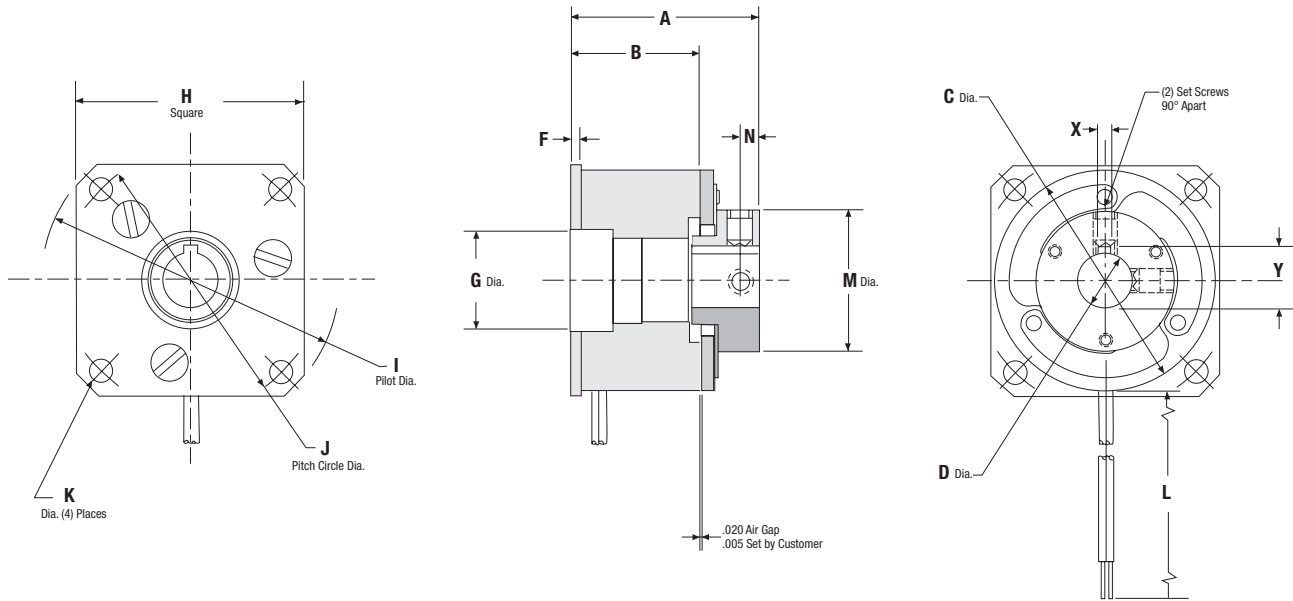

Dimensions

Model No.	A Max.	B Nom.	C Max.	D Nom.	F Max.	G ± .001	H Max.	I ± .001	J Nom.	K Min.	L ± .500	Hub Keyway		M Nom.	N Max.	
												Bore	Nominal Keyway			
090	0.885	0.634	0.905	1/8 3/16 1/4	0.034	N.A.	0.980	1.1995	1.030	0.094	12.00	N.A.	Set Screws Only	0.500	0.070	
110	0.954	0.650	1.160	3/16 1/4 5/16	0.052	N.A.	1.230	1.498	1.312	0.123	12.00	N.A.	Set Screws Only	0.687	0.093	
150	1.304	0.867	1.500	1/4 5/16 3/8	0.063	N.A.	1.567	1.999	1.750	0.156	12.00	N.A.	Set Screws Only	0.960	0.125	
180	1.269	0.848	1.780	1/4 5/16 3/8	0.064	0.751	1.943	2.436	2.125	0.186	12.00	1/4 5/16 3/8	.0625 - .0655 .0625 - .0655 .094 - .097	.285 - .290 .347 - .352 .417 - .427	1.190	0.115
200	1.330	0.901	2.000	5/16 3/8 1/2	0.062	0.751	1.943	2.436	2.125	0.186	12.00	5/16 3/8 1/2	.0625 - .0655 .094 - .097 .125 - .128	.347 - .352 .417 - .427 .560 - .567	1.190	0.115
225	1.757	1.173	2.260	3/8 1/2	0.096	1.001	2.322	2.873	2.500	0.160	18.00	3/8 1/2	.094 - .097 .125 - .128	.417 - .427 .560 - .567	1.005	0.115
265	1.815	1.300	2.645	3/8 1/2 5/8	0.080	1.062	2.630	3.499	3.125	0.182	18.00	3/8 1/2 5/8	.094 - .097 .125 - .128 .1885 - .1905	.417 - .427 .560 - .567 .709 - .716	1.440	0.150

Mechanical

Model No.	Static Torque lb. - in.	Inertia lb. - in. ²	Wt. oz.
		Arm & Hub	
090	2.5	0.0011	2.0
110	6	0.0024	3.2
150	10	0.026	3.8
180	15	0.031	11
200	25	0.042	12
225	50	0.070	20
265	80	0.320	28

Electrical

Model No.	90 VDC		24 VDC		12 VDC	
	Amps	Ohms	Amps	Ohms	Amps	Ohms
090	0.049	1970	0.117	205	0.246	48.8
110	0.047	1930	0.198	121	0.447	26.8
150	0.042	2150	0.183	132	0.380	31.6
180	0.066	1369	0.289	83	0.561	21.4
200	0.074	1213	0.322	74.4	0.574	20.9
225	0.079	1140	0.322	74.6	0.628	19.1
265	0.092	980	0.374	64.2	0.760	15.8

Flange Mounted Brake Models 325-425

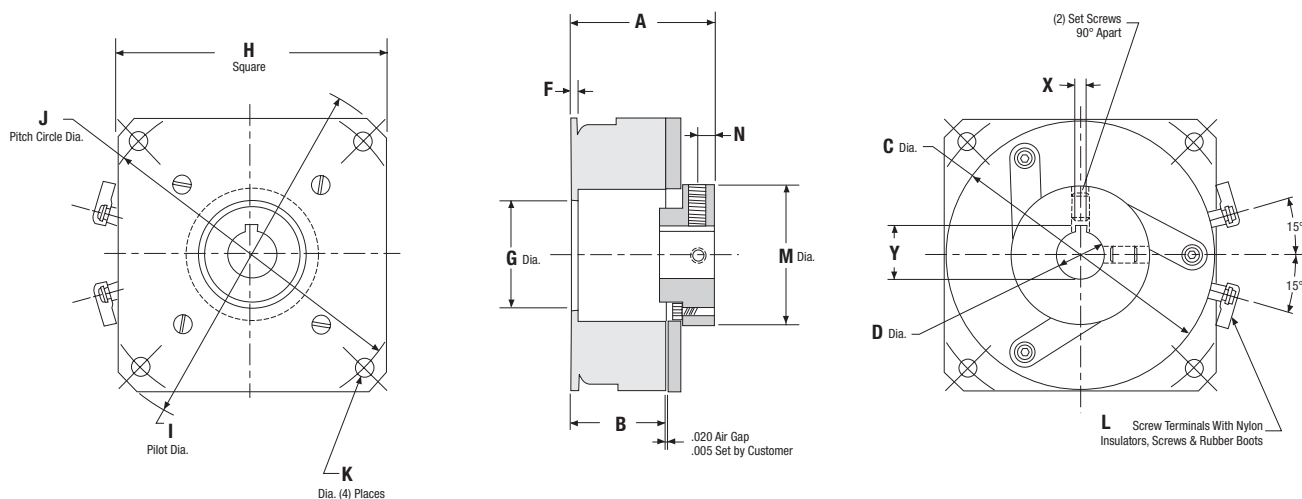

Dimensions

Model No.	A Max.	B Nom.	C Max.	D Nom.	F Max.	G ± .001	H Max.	I ± .001	J Nom.	K Min.	L	Hub Keyway		M Nom.	N Max.	
												Bore	Nominal Keyway			
													X			Y
325	1.900	1.310	3.268	1/2	0.097	1.751	3.200	4.186	3.750	0.182	Screw Terminals	1/2	.125 - .128	.560 - .567	1.825	0.150
				5/8								.1885 - .1905	.709 - .716			
				3/4								.1885 - .1905	.836 - .844			
				1/2								.125 - .128	.560 - .567			
425	2.280	1.490	4.270	5/8	0.097	1.875	4.255	5.624	5.000	0.276	Screw Terminals	5/8	.1885 - .1905	.709 - .716	2.195	0.250
				3/4								.1885 - .1905	.836 - .844			
				7/8								.1885 - .1905	.962 - .970			
				1								.251 - .253	1.113 - 1.121			

Mechanical

Model No.	Static Torque lb. - in.	Inertia lb. - in. ²	Wt. oz.
		Arm & Hub	
325	125	0.561	35
425	250	2.30	60

Electrical

Model No.	90 VDC		24 VDC		12 VDC	
	Amps	Ohms	Amps	Ohms	Amps	Ohms
325	0.091	988	0.378	65.3	0.729	16.5
425	0.124	722	0.468	51.2	0.934	12.84

Lead wire is UL recognized style 1213, 1015 or 1430, 22 gage.

Insulation is .050" O.D. on 090, 110, 150 units; .064" or .095" O.D. on all other units.

Customer shall maintain:

- Squareness of the brake mounting surface with armature shaft within .005 T.I.R.
- Concentricity between the brake mounting pilot diameter and the shaft not to exceed .010 T.I.R.
- Initial air gap setting of .005 - .020 inches.

SFPB Series

Stationary Field Clutch/Flange Mount Brake Combination For Parallel Shaft Application Models 110-265

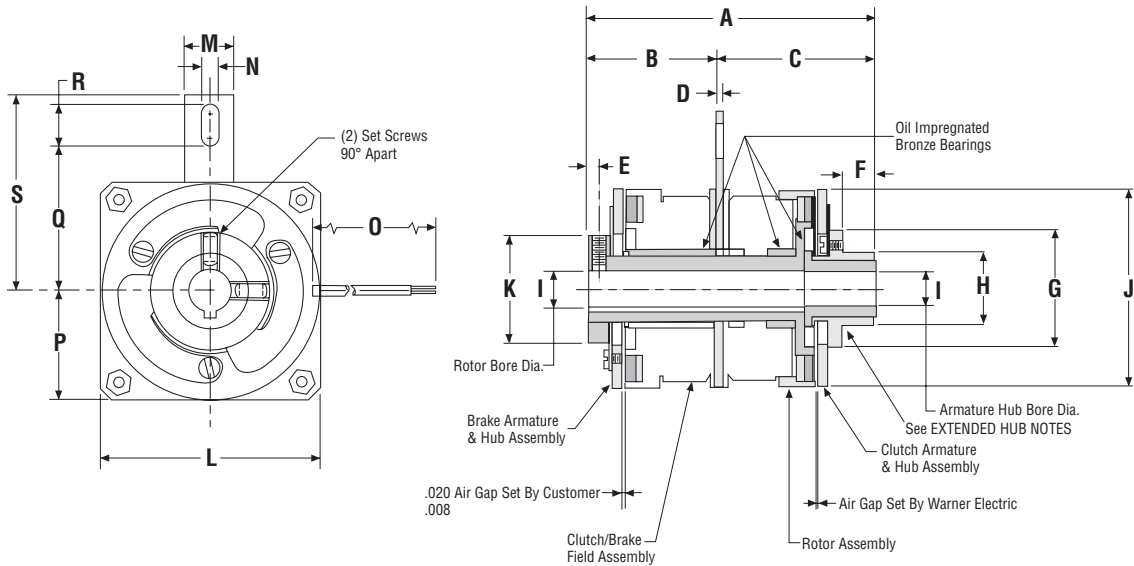

Dimensions

Model No.	A Max.	B Ref.	C Nom.	D Max.	E Nom.	F Max.	G Max.	H $\pm .002$	I Nom.	J Max.	K Max.	L Max.	M Max.	N Min.	O $\pm .500$	P Max.	Q Min.	R Min.	S Max.	Keyways		
																				Bore	Nominal Keyway	
110	2.225	0.974	1.229	0.051	0.094	0.410	0.700	.506 Knurl	1/4 5/16	1.160	0.700	1.240	0.520	0.140	12.00	0.630	0.630	0.300	1.050	N.A.	Set Screws Only	
180	2.855	1.245	1.590	0.066	0.114	0.390	1.207	0.622	1/4 5/16 3/8	1.780	1.207	1.960	0.520	0.190	12.00	0.990	1.100	0.510	1.707	1/4 5/16 3/8	.0625 - .0655 .0625 - .0655 .094 - .097	.285 - .290 .347 - .352 .417 - .427
200	2.993	1.258	1.715	0.066	0.114	0.475	1.207	0.622	5/16 3/8	2.000	1.207	1.960	0.520	0.190	12.00	0.990	1.100	0.470	1.707	5/16 3/8	.0625 - .0655 .094 - .097	.347 - .352 .417 - .427
225	3.737	1.722	1.995	0.093	0.115	0.450	1.453	0.872	3/8 1/2	2.260	1.453	2.340	0.580	0.190	18.00	1.180	1.136	0.480	1.832	3/8 1/2	.094 - .097 .125 - .128	.417 - .427 .560 - .567
265	4.050	1.778	2.240	0.093	0.150	0.427	1.610	0.998	3/8 1/2 5/8	2.640	1.450	2.650	0.645	0.190	18.00	1.335	1.730	0.480	2.395	3/8 1/2 5/8	.094 - .097 .125 - .128 .1885 - .1905	.417 - .427 .560 - .567 .709 - .716

EXTENDED HUB NOTES:

1. Extended armature hubs Models 180 and 200 (3) #4-40 tapped holes on a .812 BC
2. Extended armature hub Model 225 (3) #6-32 tapped holes on a 1.187 BC
3. Extended armature hub Model 265 (3) #8-32 tapped holes on a 1.375 BC

Mechanical (SFPB & SFPBC)

Model No.	Static Torque lb. - in.	Inertia lb. - in. ²		Wt. oz.
		Rotor	Arm & Hub	
110	6	0.0089	.0029 .0024	7
180	15	0.098	.0360 .0310	22
200	25	0.129	.0470 .0420	25
225	50	0.295	.0790 .0700	45
265	80	0.660	.2920 .3200	60

Customer shall maintain:

- A loose-fitting pin through the anti-rotation tab to prevent preloading the bearings.
- Initial air gap setting of .008 - .020 inches.

Stationary Field Clutch Coupling/Flange Mount Brake Combination For In-Line Shaft Application Models 110-265

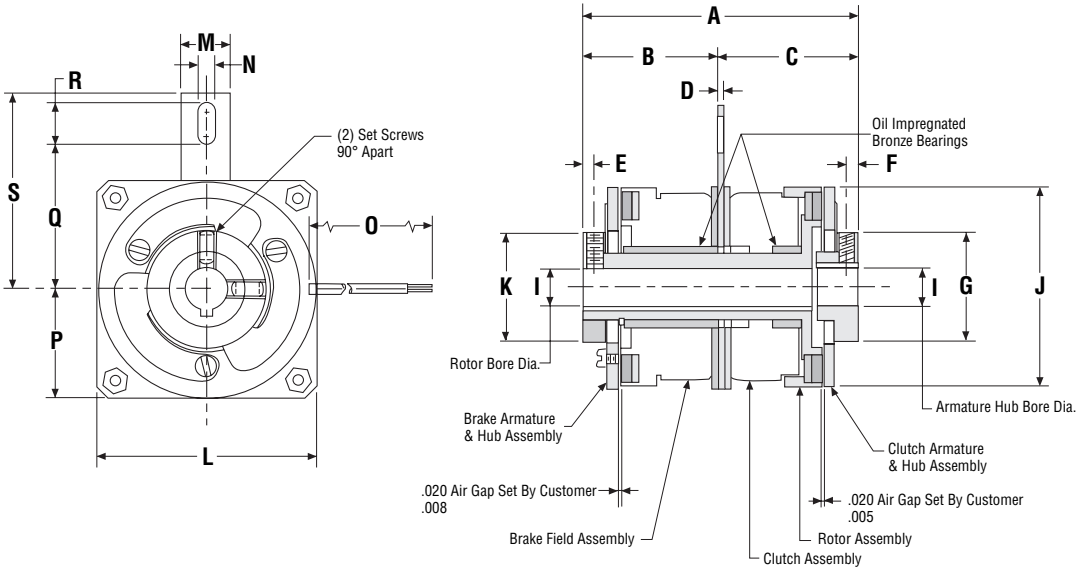

Dimensions

Model No.	A Max.	B Ref.	C Nom.	D Max.	E Nom.	F Nom.	G Max.	H Nom.	I Nom.	J Max.	K Max.	L Max.	M Max.	N Min.	O ± .500	P Max.	Q Min.	R Min.	S Max.	Keyways		
																				Bore	Nominal Keyway	
110	1.970	0.974	0.983	0.051	0.094	0.094	0.700	-	1/4 5/16	1.160	0.700	1.240	0.520	0.140	12.00	0.630	0.630	0.300	1.050	N.A.	Set Screws Only	
180	2.608	1.245	1.340	0.066	0.114	0.114	1.207	-	1/4 5/16 3/8	1.780	1.207	1.960	0.520	0.190	12.00	0.990	1.100	0.470	1.707	1/4 5/16 3/8	.0625 - .0655 .094 - .097	.285 - .290 .347 - .352 .417 - .427
200	2.615	1.258	1.337	0.066	0.114	0.114	1.207	-	5/16 3/8	2.000	1.207	1.960	0.520	0.190	12.00	0.990	1.100	0.470	1.707	5/16 3/8	.0625 - .0655 .094 - .097	.347 - .352 .417 - .427
225	3.552	1.722	1.810	0.093	0.115	0.115	1.453	-	3/8 1/2	2.260	1.453	2.340	0.580	0.190	18.00	1.180	1.136	0.480	1.832	3/8 1/2	.094 - .097 .125 - .128	.417 - .427 .560 - .567
265	3.677	1.815	1.842	0.093	0.150	0.150	1.450	-	3/8 1/2 5/8	2.640	1.450	2.650	0.645	0.190	18.00	1.335	1.730	0.480	2.395	3/8 1/2 5/8	.094 - .097 .125 - .128 .1885 - .1905	.417 - .427 .560 - .567 .709 - .716

Electrical (SFPB & SFPBC)

Model No.	90 VDC		24 VDC		12 VDC	
	Amps	Ohms	Amps	Ohms	Amps	Ohms
110	0.047	1930	0.198	121	0.447	26.8
180	0.066	1369	0.289	83	0.561	21.4
200	0.074	1213	0.322	74.4	0.574	20.9
225	0.079	1140	0.322	74.6	0.628	19.1
265	0.088	1024	0.350	67.1	0.667	18.0

Lead wire is UL recognized style 1213, 1015 or 1429, 22 gage.

Insulation is .050" O.D. on 110 unit; .064" or .095" O.D. on all other units.

Customer shall maintain:

- A loose-fitting pin through the anti-rotation tab to prevent preloading the bearings.
- Concentricity between the shafts within .005 T.I.R.
- Initial air gap setting of .008 - .020 inches.

Selection Criteria

Determining the Clutch or Brake Size

First, determine which style clutch or brake you need. The type of unit selected depends upon the function to be performed.

Next, determine the size of the clutch or brake. There are two methods you can use to calculate the dynamic torque required.

$$T_d = \left[\frac{WR^2 \times N \pm T_L}{C \times t} \right] \times \text{S.F.}$$

Where:

WR^2 = Total inertia reflected to the clutch/brake, lb.-in.² (kg. m²)

N = Shaft speed at clutch/brake, RPM

C = Constant, use 3696 for English units and 9.55 for metric units

t = Desired stopping or acceleration time, seconds

T_L = Load torque to overcome other than inertia, lb.-in. (N-m)

S.F. = Service Factor, 1.4 recommended

T_d = Average dynamic torque, lb.-in. (N-m)

Note:

+ T_L = engage a clutch or accelerate

- T_L = brake or decelerate

Warner Electric™ clutches and brakes are rated by static torque. The clutch or brake size can also be determined using the selection chart. Find the intersection of the prime mover horsepower (HP) and shaft speed at the brake using the selection chart on Page 4. The relationship between the horsepower and speed to determine the dynamic torque required is expressed as:

$$T_d = \frac{63,025 \times P}{N} \times \text{S.F.}$$

Where:

T_d = Average dynamic torque, lb.-in.

P = Horsepower, HP

N = Shaft Speed

S.F. = Service Factor

63,025 = Constant

Dynamic Torque Curve

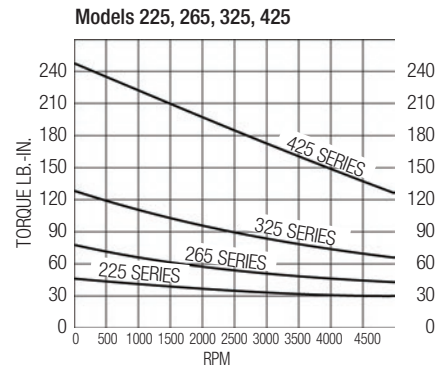
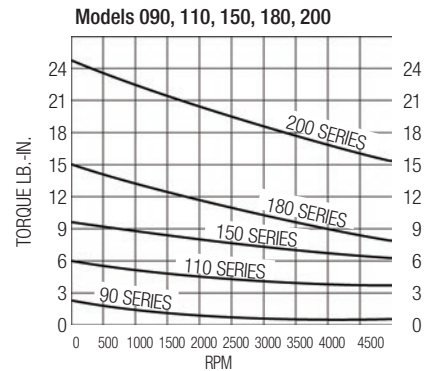

Torque Data

Clutches: Clutch Couplings: Power On Brakes			
Models	Typical Out-Of-Box Torques LB. - IN.	Rated Static Torques LB. - IN.	Typical Torques After Burnishing LB. - IN.
090	2	2.5	3
110	5	6	8
150	8	10	15
180	12	15	20
200	20	25	30
225	40	50	60
265	65	80	90
325	100	125	150
425	225	250	275

Response Times for Clutches & Brakes

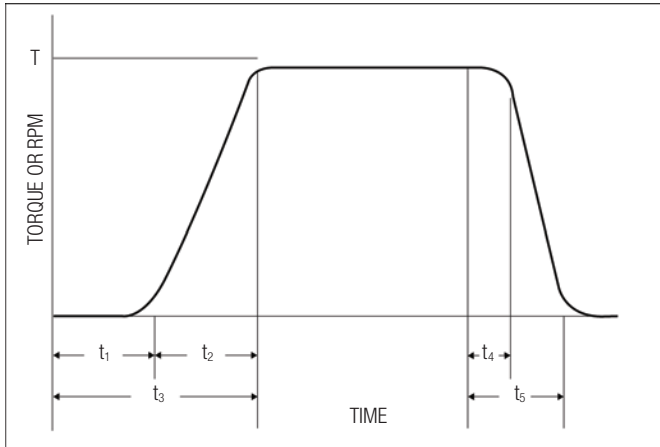

Where:

- t_1 = Delay time when engaging
- t_2 = Torque rise time
- t_3 = Time to full torque or speed
- t_4 = Disengaging time (90% torque)
- t_5 = Time to zero speed
- T = Full torque or speed

Response Times

Model	Rated Static Torque LB. – IN.	Torque Build-Up Time Milliseconds		Torque Decay Time Ms
		80% Of Rated Torque	100% Of Rated Torque	10% Of Rated Torque
090	2.5	4.8	7.5	6.6
110	6	7.2	10.5	11
150	10	9	12	17
180	15	10	14	14
200	25	33	48	35
225	50	27	42	20
265	80	22	40	30
325	125	43	60	36
425	250	45	70	50

Notes:

1. Torque decay time is dependent on the type of arc suppression circuit used. Decay times shown in table assume use of a diode in parallel with the coil for arc suppression. If no arc suppression is used, torque will decay almost instantly.
2. Actual response times depend on several factors such as inertia being accelerated or decelerated, speed, load torque, and type of switching used.
3. Time to full torque can be shortened by applying overexcitation voltages up to 50 times the rated coil voltage.
4. The time to full torque is also dependent on the voltage supply. If the clutch or brake is underpowered (low voltage), a decrease in torque will result. The clutch or brake should be sized based upon the worst-case voltage condition. The DC voltage supply should be filtered full wave for highest efficiency. Half wave DC voltage will result in lower torque output.

How To Order

Building an Ordering Part Number is fast and easy using the Specifications charts on each product page. Simply select the clutch type, clutch size, bore size(s) and voltage you require.

Ordering Number

Example: SFC200-516-316-12-XX

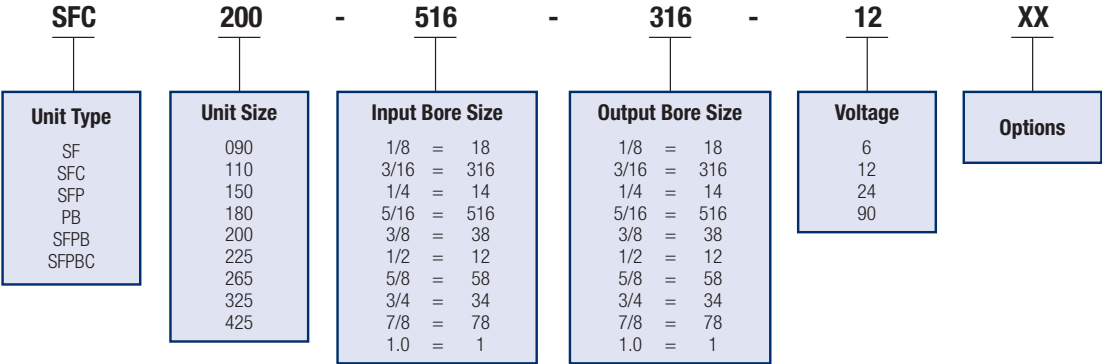



Stop seeing individual parts. Start seeing unlimited possibilities.

Regardless of your objectives or the challenges with your application, Powertrain Solutions can help you achieve your unique goals. No matter what your application looks like, it relies on many components, all working together. But not all components are made to work together reliably and efficiently. Powertrain Solutions has the insight, experience and expertise to engineer your collection of components into a fully optimized system — giving you solutions that boost efficiency, improve reliability and performance, lower costs and simplify ordering and logistics.

WHERE OTHERS SEE PARTS, WE SEE A SYSTEM



Bearings



Belt & Chain
Drives



Clutches &
Brakes



Conveying



Disc & Gear
Couplings



Motors



Speed Reducers
& Gearboxes



Monitoring &
Diagnostics

It's time to see the bigger picture.

Get started at RegalRexnord.com/Powertrain



Regal Rexnord

regalrexnord.com warnerelectric.com

Customer Service: 800-825-6544

Technical Service: 800-825-9050

uscustomer@regalrexnord.com

The proper selection and application of products and components, including assuring that the product is safe for its intended use, are the responsibility of the customer. To view our Application Considerations, please visit <https://www.regalrexnord.com/Application-Considerations>.

To view our Standard Terms and Conditions of Sale, please visit <https://www.regalrexnord.com/Terms-and-Conditions-of-Sale> (which may redirect to other website locations based on product family).

"Regal Rexnord" is not indicative of legal entity. Refer to product purchase documentation for the applicable legal entity. Regal Rexnord, and Warner Electric are trademarks of Regal Rexnord Corporation or one of its affiliated companies. © 2018, 2026 Regal Rexnord Corporation, All Rights Reserved. MCC-P-1630-WE-EN-US 04/26

